

AIRPLANE FLIGHT MANUAL

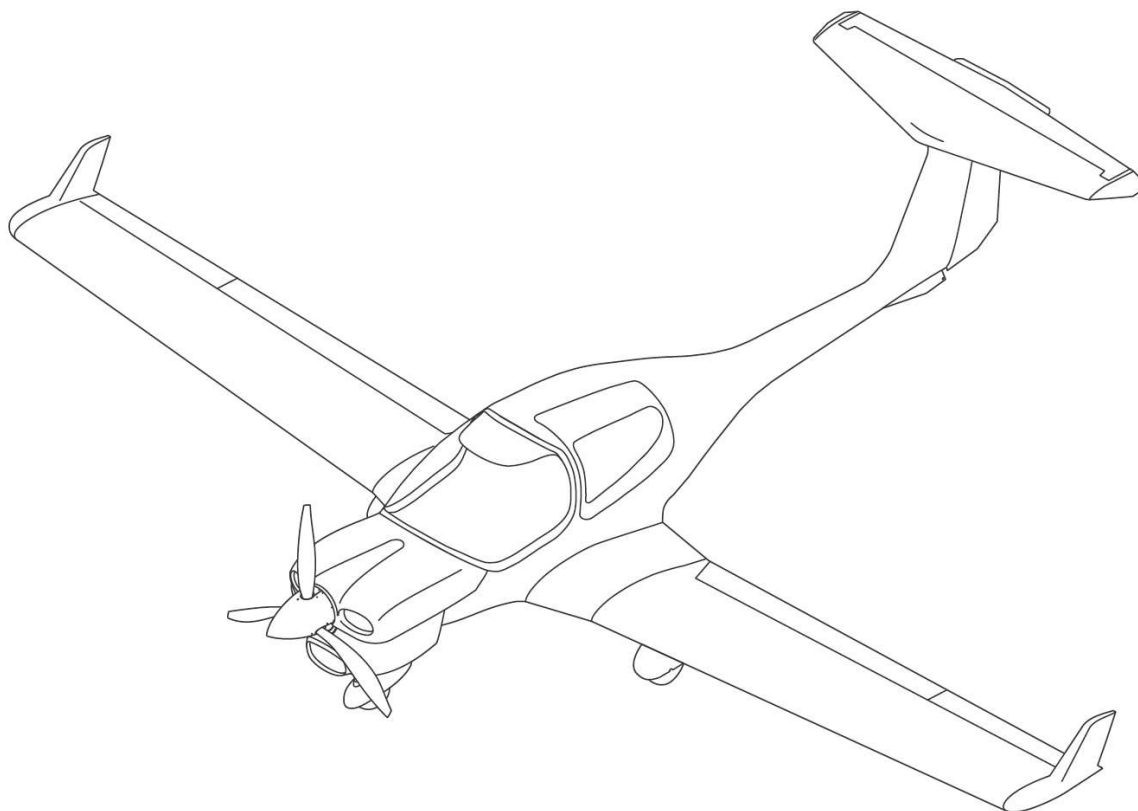

DA 40 NG

Doc. # 6.01.15-E

DIAMOND AIRCRAFT INDUSTRIES INC.
1560 CRUMLIN SIDEROAD, LONDON, ONTARIO
CANADA, N5V 1S2

All rights reserved. No part of this manual may be reproduced or copied
in any form or by any means without written permission
of DIAMOND AIRCRAFT INDUSTRIES INC.

Copyright © 2020 by DIAMOND AIRCRAFT INDUSTRIES INC., London, Ontario

REV 4

Initial issue: 01-Apr-2010
Current issue: 31-Dec-2024

This manual contains the maintenance information required by AWM Chapter 523. Contents and revision status can be found in the TABLE OF CONTENTS and the RECORD OF REVISIONS.

DIAMOND AIRCRAFT INDUSTRIES INC.
1560 CRUMLIN SIDEROAD
London, Ontario, Canada, N5V 1S2

<http://www.diamondaircraft.com/>

For more information contact:

DIAMOND AIRCRAFT INDUSTRIES INC.
Technical Publications
+1-519-457-4000
techpubs@diamondaircraft.com

AIRPLANE FLIGHT MANUAL

DA 40 NG

Airworthiness Category : Normal

Requirement : **AWM Chapter 523**

Serial Number : _____

Registration : _____

Doc. # : **6.01.15-E**

Date of Issue : **31-Dec-2024**

Signature

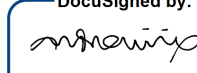
DocuSigned by:

 : 2BE2FBE348AE416...
 Andreas Hartono

Authority : A/Chief, Flight Test For
 Director, Aircraft Certification
 Transport Canada Civil Aviation

Date of Approval : February 20, 2025

This Airplane Flight Manual is approved in accordance with the Canadian Aviation Regulations.

This Airplane Flight Manual is FAA approved for U.S. registered aircraft in accordance with the provisions of 14 CFR Section 21.29, and is required by FAA Type Certificate Data Sheet no.: A47CE.

DIAMOND AIRCRAFT INDUSTRIES INC.
1560 CRUMLIN SIDEROAD
London, Ontario, Canada
N5V 1S2

FOREWORD

We congratulate you on the acquisition of your new DIAMOND DA 40 NG.

Skillful operation of an airplane increases both safety and the enjoyment of flying. Please take the time therefore, to familiarize yourself with your new DIAMOND DA 40 NG.

This airplane may only be operated in accordance with the procedures and operating limitations of this Airplane Flight Manual.

Before this airplane is operated for the first time, pilots must familiarize themselves with the complete contents of this Airplane Flight Manual.

In the event that you have obtained your DIAMOND DA 40 NG second-hand, please let us know your address, so that we can supply you with the publications necessary for the safe operation of your airplane.

This document is protected by copyright. All associated rights, in particular those of translation, reprinting, radio transmission, reproduction by photo-mechanical or similar means and storing in data processing facilities, in whole or part, are reserved.

Copyright © by: DIAMOND AIRCRAFT INDUSTRIES INC.
1560 Crumlin Sideroad
London, Ontario, Canada, N5V 1S2
Phone : +1-519-457-4000
E-Mail : Techpubs@diamondaircraft.com

0.1 APPROVAL

The content of approved chapters is approved by the Department of Transport.

0.2 RECORD OF REVISIONS

All revisions of this manual, with the exception of

- Temporary Revisions,
- updates of the modification level (Section 1.1),
- updated mass and balance information (Section 6.3),
- updates of the Equipment Inventory (Section 6.5), and
- updates of the List of Supplements (Section 9.2)

must be recorded in the following table.

The new or amended text is indicated by a vertical black line at the left hand side of the revised page, with the revision number and date appearing at the bottom of the page.

If pages are revised which contain information valid for your particular serial number (modification level of the airplane, weighing data, Equipment Inventory, List of Supplements), then this information must be transferred to the new pages in hand-writing.

Temporary Revisions are used to provide information on systems or equipment until the next “permanent” revision of the Airplane Flight Manual. When a “permanent” Revision covers a Mandatory or Optional Design Change Advisory (MÄM or OÄM), then the corresponding Temporary Revision is superseded. For example: if Revision 5 covers OÄM 40-039, then the Temporary Revision TR-OÄM 40-039 is superseded by the “permanent” Revision 5.

Cover pages of Temporary Revisions, if applicable, are inserted behind the cover page of this manual, all other pages are inserted in front of the affected pages of this manual.

Rev. No.	Reason	Chapter	Page(s)	Date of Revision	Approval Note	Date of Approval	Date Inserted	Signature
1	<p>MÄM-40- -415, -432, -440, -448, -460, -466, -447, -514</p> <p>OÄM-40- -311, -313, -314, -316, -321, -326, -327, -329, -330, -331, -333</p> <p>Corrections</p>	All	All except cover page	15-Mar-2011	Revision 1 of the AFM Doc. No. 6.01.15-E is approved with EASA approval No. 10034114.	08-Mar-2011		
2	<p>MÄM-40- -434, -451, -321/a</p> <p>OÄM-40-310</p> <p>FAA approval</p>	0, 1, 2, 5, 6	0-0, 0-0a, 0-3, 0-5, 0-6, 0-9, 0-10, 1-2, 1-3, 2-24, 5-1, 5-31, 5-32, 6-16 through 6-26	15-Jun-2011	Revision 2 of the AFM Doc. No. 6.01.15-E is approved by EASA under project No. 0010005331	24-Nov-2011		

Rev. No.	Reason	Chapter	Page(s)	Date of Revision	Approval Note	Date of Approval	Date Inserted	Signature
3	<p>MÄM 40- -777/a, -766, -765, -754, -751, -742, -731, -710/a, -674, -672, -662, -638, -631, -632, -618/a & OÄM 40-321/b, -574, -563, -562, -561, -559, -558, -547, -533, -488, -429/a, -551</p> <p>OÄM 40- -321/b, -237, -183, -334/a, -314/d & 40-316/d, -340, -341, -336/a, -326/a, -252, -258, -312, -362, -369, -370, -371, -377, -381</p> <p>Corrections</p>	All	All except cover page	01-Jul-2014	Revision 3 of the AFM Doc. No. 6.01.05-E is approved under the authority of DOA No. EASA.21.J.052	29-Jan-2015		

Rev. No.	Reason	Chapter	Page(s)	Date of Revision	Approval Note	Date of Approval	Date Inserted	Signature
4	<p>MÄM 40- -447, -580, -780, -805, -816, -833, -838/a, -866, -868, -874, -879, -880, -896, -1007, -1020, -1060, -1064, -1086, -1087, -1090, -1098, -1112, -1119, -1123, 1188 and DAIC-0042</p> <p>OÄM 40- -251, -314/f & 316/f, -321/c, -337, -375, -390, -392, -401, -1000/f, -1003/f -1029 and -1030</p> <p>Corrections</p>	All	All	31-Dec-2024	Approved by TCCA, National Aircraft Certification	20-Feb-2025		

0.3 HIGHLIGHTS

A new cover page was inserted in front of the Approval Page.

The tables that follow highlight the main changes that have been incorporated into Revision 4 of the Airplane Flight Manual.

Revision bars and the date of 31-Dec-2024 will show on the changed pages in the List of Effective Pages (LOEP). Revision bars on the changed pages will show where the content changes were made.

Pages	Highlights
Front Matter	Cover page added. EASA approval page replaced by TC approval page. Diamond Aircraft Industries address changed. Record of Revision for revision 4 added and editorial changes. Highlights added. LEP updated. Editorial changes in the Table of Contents.
Chapter 1 - General	
1-1, 2	Table of contents updated.
1-3	Regulation updated. Modification table updated. Following temporary revisions incorporated: <ul style="list-style-type: none"> - TR-MÄM-40-868, Garmin G1000 NXi Avionics System - TR-MÄM-40-1007, Garmin G1000 Avionics System - TR-OÄM-40-375, Front Seats with Adjustable Backrest – Hydrolok
1-4	Modification table updated. Following temporary revisions incorporated: <ul style="list-style-type: none"> - TR-OÄM-40-1029/a, MD302 Standby Attitude Module - TR-MÄM-40-838/a, EECU Software VC33_1_05_19 - TR-MÄM 40-1060, USB Ports TR-OÄM-40-401, Emergency Egress Hammer
1-5	Certification basis updated.
1-6, 7, 8	Heading level updated.
1-9	Heading description improved. Heading level updated.
1-10, 11	Heading level updated.
1-13	Heading level updated. JAR abbreviation deleted.
1-20	Intentionally left blank page added.
Chapter 2 - Operating Limitations	
2-1, 2	Table of contents updated.
2-4	Quotation marks removed.
2-7	Approved engine oil types updated. TR-MÄM-40-874, Engine Oils, incorporated.
2-8	Approved engine oil types updated. Caution revised. TR-MÄM-40-838/a, EECU Software VC33_1_05_19, incorporated.

Pages	Highlights
2-9	TR-MÄM-40-780, Coolant Temperature Upper Caution Range 100°C-105°C, incorporated.
2-10	Heading level updated. Wording improvement.
2-11	TR-MÄM-40-868, Garmin G1000 NXi Avionics System, incorporated.
2-12	Heading level updated. Editorial change.
2-13	Heading level updated. Wording improvement.
2-14	Editorial improvement.
2-15	Heading level updated.
2-16	Heading level updated. JAR 23 replaced by AWM 523.
2-18	Heading level updated. JAR 23 replaced by AWM 523. Minimum operational equipment information added (transferred from page 2-20).
2-20	Minimum operational equipment information moved to page 2-18.
2-21	Following temporary revisions incorporated: - TR-MÄM-40-838/a, EECU Software VC33_1_05_19 - TR-MÄM-40-1086, Kathon FP 1.5 Biocide Discontinuation - TR-MÄM-40-1112, China No. 3 Fuel Standard GB 6537-2018
2-22	Heading level updated. TR-MÄM-40-1086, Kathon FP 1.5 Biocide Discontinuation, incorporated. Caution and note added.
2-23	Heading level updated. TR-MÄM-40-1188, Fuel System Limitations, incorporated.
2-25	TR-MÄM-40-874, Engine Oils, incorporated.
2-30	Battery charge statement improved.
2-31	TR-MÄM-40-833, Electronic Equipment, incorporated.
2-32	Intentionally left blank page added.
Chapter 3 - Emergency Procedures	
3-1, 2	Table of contents updated.
3-3	Editorial change.
3-5, 6, 12	Heading level updated.
3-14	Editorial change.
3-18, 19, 21	Heading level updated.
3-22	TR-MÄM-40-838/a, EECU Software VC33_1_05_19, incorporated. Procedure to restart the engine in flight updated.
3-23	Procedure to restart the engine in flight updated.
3-28	Editorial change.
3-29	Heading level updated. Editorial correction. Note related to the electrical power of the backup instruments updated.

Pages	Highlights
3-30	TR-MÄM-40-805, Removal of High Current Procedure, incorporated.
3-31, 37, 41	Editorial correction.
3-42	Heading level updated.
3-43	Editorial change.
3-44	Heading level updated.
Chapter 4A - Normal Operating Procedures	
4A-1	Table of contents updated.
4A-2	Intentionally left blank page added.
4A-3	TR-MÄM-40-868, Garmin G1000 NXi Avionics System, incorporated. Editorial correction.
4A-5	Editorial change.
4A-6	Following temporary revisions incorporated: - TR-OÄM-40-401, Emergency Egress Hammer - TR-MÄM DAIC-0042, Amerex 337TS Fire Extinguisher
4A-7, 8	Editorial change.
4A-11	Engine oil caution added.
4A-22	Heading level updated.
4A-23	TR-MÄM-40-879, Adaption of ECU Selftest RPM, incorporated. Editorial correction.
4A-25, 27, 29, 33, 34	Heading level updated.
4A-37	TR-MÄM-40-868, Garmin G1000 NXi Avionics System, incorporated.
4A-39	Heading level updated.
4A-40	Following temporary revisions incorporated: - TR-MÄM-40-1086, Kathon FP 1.5 Biocide Discontinuation - TR-MÄM-40-1188, Fuel System Limitations
Chapter 4B - Abnormal Operating Procedures	
4B-1, 2	Table of contents updated.
4B-3	Editorial change.
4B-5, 8, 9	Heading level updated.
4B-13, 15	Editorial change.
4B-22	Heading level updated.
4B-30	TR-MÄM-40-1087, Use of Alt. Static Source, incorporated.
Chapter 5 - Performance	
5-1	Table of contents updated.

Pages	Highlights
5-2	Intentionally left blank page added.
5-8	Heading level updated.
5-11	Text layout changed.
5-17, 20, 23	Editorial correction.
5-26	TR-MÄM-40-880, Adaption of Cruise Performance Conditions, incorporated.
5-38	Editorial correction.
5-42	CS-36 Subpart C deleted.
Chapter 6 - Mass and Balance / Equipment List	
6-1	Table of contents updated.
6-2	Intentionally left blank page added.
6-3, 6, 7	Editorial change.
6-10, 12	Heading level updated.
6-16	Editorial change.
6-17, 18, 19	Header improved.
6-20	ELT unit added. Following temporary revisions incorporated: <ul style="list-style-type: none"> - TR-MÄM 40-1060, USB Ports - TR-MÄM DAIC-0042, Amerex 337TS Fire Extinguisher - TR-OÄM-40-401, Emergency Egress Hammer, incorporated
6-21, 22	TR-MÄM-40-868, Garmin G1000 NXi Avionics System, incorporated.
6-23	Header improved.
6-24	TR-MÄM-40-1007, Garmin G1000 Avionics System, incorporated.
6-25	Backup artificial horizon equipment added. Following temporary revisions incorporated: <ul style="list-style-type: none"> - TR-MÄM-40-868, Garmin G1000 NXi Avionics System - TR-MÄM-40-896, Update of Equipment List - TR-MÄM-40-1007, Garmin G1000 Avionics System
6-26	Part number of data link processor corrected. Following temporary revisions incorporated: <ul style="list-style-type: none"> - TR-OÄM-40-390, Transponder GTX33ES - TR-OÄM-40-1003, Garmin GTX 335R/345R with ADS-B - TR-MÄM-40-868, Garmin G1000 NXi Avionics System - TR-MÄM-40-1007, Garmin G1000 Avionics System
6-27	Following temporary revisions incorporated: <ul style="list-style-type: none"> - TR-MÄM-40-1123, Transponder Coupler - TR-OÄM 40-1030, Avidyne TAS6XXA, incorporated

Pages	Highlights
6-28	TR-OÄM-40-1029/a, MD302 Standby Attitude Module, incorporated.
6-29	Following temporary revisions incorporated: - TR-MÄM-40-1064, AHY Engine - TR-MÄM-40-1090, BHY Engine
6-30	TR-MÄM-40-1007, Garmin G1000 Avionics System, incorporated.
6-31	Following temporary revisions incorporated: - TR-MÄM-40-816, Alternate Means for Fuel Quantity Measurement - TR-MÄM-40-580, Equipment List: Landing Gear Components
6-32	TR-MÄM-40-580, Equipment List: Landing Gear Components, incorporated.
Chapter 7 - Description of the Airplane and its Systems	
7-1, 2	Table of contents updated.
7-3, 4, 5, 6, 7	Heading level updated. Editorial change.
7-8	Heading level updated. Unlock pedals note added.
7-9	TR-OÄM-40-251, Electrical Pedal Adjustment, incorporated.
7-13	Editorial improvement.
7-14	Heading level updated. Editorial change.
7-16	TR-OÄM-40-1029/a, MD302 Standby Attitude Module, incorporated.
7-17	Heading level updated. Parking brake release instruction improved.
7-18	Illustration title added.
7-19, 20, 22	TR-OÄM-40-375, Front Seats with Adjustable Backrest – Hydrolok, incorporated.
7-23, 24, 25	Heading level update. Editorial correction.
7-26	TR-OÄM-40-401, Emergency Egress Hammer, incorporated.
7-27	Fire extinguisher and engine displacement information added.
7-28, 29, 30, 31	Heading level update.
7-36	Long range tanks statement improved.
7-37, 38, 39	Heading level update. Editorial change.
7-40	Heading level update. Horizontal ground replaced by level ground.
7-41	Illustration title added.
7-42, 43, 44	TR-MÄM-40-816, Alternate Means for Fuel Quantity Measurement, incorporated.
7-47	Heading level updated. Gear replaced by gearbox.
7-49, 50	Heading level update.

Pages	Highlights
7-51	Heading level update. Wording improvement.
7-52	Mentioned section title corrected. Heading level update.
7-53	Heading level update.
7-54	Heading level update. Illustration corrected.
7-55, 56	Heading level update.
7-57	TR-MÄM-40-866, Types of ECU-Cautions, incorporated.
Chapter 8 - Airplane Handling, Care and Maintenance	
8-1	Table of contents updated.
8-2	Intentionally left blank page added.
8-7	Heading level updated.
8-8	Note related to the gust lock figures added.
8-9	TR-MÄM-40-1020, Removal of Pilot Gust Lock Mount, incorporated.
8-11, 13	Heading level updated.
8-14	Heading title improved. Heading title added. Editorial change.
Chapter 9 - Supplements	
9-1	Table of contents updated.
9-2	Intentionally left blank page added.
9-4	Following temporary revisions incorporated: - TR-MÄM-40-447, Garmin G1000 Avionics System - TR-MÄM-40-868, Garmin G1000 NXi Avionics System - TR-MÄM-40-1007, Garmin G1000 Avionics System
9-5	Following temporary revisions incorporated: - TR-MÄM-40-1112, China No. 3 Fuel Standard GB 6537-2018 - TR-MÄM-40-1119/a, D64-9028-11-01 Fuel Pumps - TR-MÄM-40-1188, Fuel System Limitations - TR-OÄM-40-314/f & 316/f, Additional Alternator & Recirculating Air - Cabin Cooling - TR-OÄM-40-321/c, Conventional Cockpit DA 40 NG Club - TR-OÄM 40-337, Flight Data Logging Device - TR-OÄM-40-1003, Garmin GTX 335R/345R with ADS-B
9-6	Intentionally left blank page added.

Temporary Revisions incorporated into this revision are listed in the table that follows.

Temporary Revision Number	Description of Temporary Revision
TR-MÄM-40-447	Garmin G1000 Avionics System
TR-MÄM-40-580	Equipment List: Landing Gear Components
TR-MÄM-40-780	Coolant Temperature Upper Caution Range 100°C-105°C
TR-MÄM-40-805	Removal of High Current Procedure
TR-MÄM-40-816	Alternate Means for Fuel Quantity Measurement
TR-MÄM-40-833	Electronic Equipment
TR-MÄM-40-838/a	EECU Software VC33_1_05_19
TR-MÄM-40-866	Types of ECU-Cautions
TR-MÄM-40-868	Garmin G1000 NXi Avionics System
TR-MÄM-40-874	Engine Oils
TR-MÄM-40-879	Adaption of ECU Selftest RPM
TR-MÄM-40-880	Adaption of Cruise Performance Conditions
TR-MÄM-40-896	Update of Equipment List
TR-MÄM-40-1007	Garmin G1000 Avionics System
TR-MÄM-40-1020	Removal of Pilot Gust Lock Mount
TR-MÄM 40-1060	USB Ports
TR-MÄM-40-1064	AHY Engine
TR-MÄM-40-1086	Kathon FP 1.5 Biocide Discontinuation
TR-MÄM-40-1087	Use of Alt. Static Source
TR-MÄM-40-1090	BHY Engine
TR-MÄM-40-1112	China No. 3 Fuel Standard GB 6537-2018
TR-MÄM-40-1119/a	D64-9028-11-01 Fuel Pumps
TR-MÄM-40-1123	Transponder Coupler
TR-MÄM-40-1188	Fuel System Limitations
TR-MÄM DAIC-0042	Amerex 337TS Fire Extinguisher
TR-OÄM-40-251	Electrical Pedal Adjustment
TR-OÄM-40-314/f & 316/f	Additional Alternator & Recirculating Air - Cabin Cooling
TR-OÄM-40-321/c	Conventional Cockpit DA 40 NG Club
TR-OÄM 40-337	Flight Data Logging Device
TR-OÄM-40-375	Front Seats with Adjustable Backrest – Hydrolok
TR-OÄM-40-390	Transponder GTX33ES
TR-OÄM-40-392	Provisionary Installation of Reinforced Landing Gear
TR-OÄM-40-401	Emergency Egress Hammer

Temporary Revision Number	Description of Temporary Revision
TR-OÄM-40-1003	Garmin GTX 335R/345R with ADS-B
TR-OÄM-40-1029/a	MD302 Standby Attitude Module
TR-OÄM 40-1030	Avidyne TAS6XXA
TR-17-04	Change in Type Design Responsibility

0.4 LIST OF EFFECTIVE PAGES

Ch.	Page	Date
0	0-1	31-Dec-2024
	0-2	31-Dec-2024
	0-3	31-Dec-2024
	0-4	31-Dec-2024
	0-5	31-Dec-2024
	0-6	31-Dec-2024
	0-7	31-Dec-2024
	0-8	31-Dec-2024
	0-9	31-Dec-2024
	0-10	31-Dec-2024
	0-11	31-Dec-2024
	0-12	31-Dec-2024
	0-13	31-Dec-2024
	0-14	31-Dec-2024
	0-15	31-Dec-2024
	0-16	31-Dec-2024
	0-17	31-Dec-2024
	0-18	31-Dec-2024
	0-19	31-Dec-2024
	0-20	31-Dec-2024
	0-21	31-Dec-2024
	0-22	31-Dec-2024

Ch.	Page	Date
1	1-1	31-Dec-2024
	1-2	31-Dec-2024
	1-3	31-Dec-2024
	1-4	31-Dec-2024
	1-5	31-Dec-2024
	1-6	31-Dec-2024
	1-7	31-Dec-2024
	1-8	31-Dec-2024
	1-9	31-Dec-2024
	1-10	31-Dec-2024
	1-11	31-Dec-2024
	1-12	31-Dec-2024
	1-13	31-Dec-2024
	1-14	31-Dec-2024
	1-15	31-Dec-2024
	1-16	31-Dec-2024
	1-17	31-Dec-2024
	1-18	31-Dec-2024
	1-19	31-Dec-2024
	1-20	31-Dec-2024

Ch.	Page	Date
2	2-1	31-Dec-2024
	2-2	31-Dec-2024
	2-3	31-Dec-2024
	2-4	31-Dec-2024
	2-5	31-Dec-2024
	2-6	31-Dec-2024
	2-7	31-Dec-2024
	2-8	31-Dec-2024
	2-9	31-Dec-2024
	2-10	31-Dec-2024
	2-11	31-Dec-2024
	2-12	31-Dec-2024
	2-13	31-Dec-2024
	2-14	31-Dec-2024
	2-15	31-Dec-2024
	2-16	31-Dec-2024
	2-17	31-Dec-2024
	2-18	31-Dec-2024
	2-19	31-Dec-2024
	2-20	31-Dec-2024
	2-21	31-Dec-2024
	2-22	31-Dec-2024
	2-23	31-Dec-2024
	2-24	31-Dec-2024
	2-25	31-Dec-2024
	2-26	31-Dec-2024
	2-27	31-Dec-2024
	2-28	31-Dec-2024
2-29	31-Dec-2024	
2-30	31-Dec-2024	

Ch.	Page	Date
2	2-31	31-Dec-2024
	2-32	31-Dec-2024

Ch.	Page	Date
3	3-1	31-Dec-2024
	3-2	31-Dec-2024
	3-3	31-Dec-2024
	3-4	31-Dec-2024
	3-5	31-Dec-2024
	3-6	31-Dec-2024
	3-7	31-Dec-2024
	3-8	31-Dec-2024
	3-9	31-Dec-2024
	3-10	31-Dec-2024
	3-11	31-Dec-2024
	3-12	31-Dec-2024
	3-13	31-Dec-2024
	3-14	31-Dec-2024
	3-15	31-Dec-2024
	3-16	31-Dec-2024
	3-17	31-Dec-2024
	3-18	31-Dec-2024
	3-19	31-Dec-2024
	3-20	31-Dec-2024
	3-21	31-Dec-2024
	3-22	31-Dec-2024
	3-23	31-Dec-2024
	3-24	31-Dec-2024
	3-25	31-Dec-2024

Ch.	Page	Date
3	3-26	31-Dec-2024
	3-27	31-Dec-2024
	3-28	31-Dec-2024
	3-29	31-Dec-2024
	3-30	31-Dec-2024
	3-31	31-Dec-2024
	3-32	31-Dec-2024
	3-33	31-Dec-2024
	3-34	31-Dec-2024
	3-35	31-Dec-2024
	3-36	31-Dec-2024
	3-37	31-Dec-2024
	3-38	31-Dec-2024
	3-39	31-Dec-2024
	3-40	31-Dec-2024
	3-41	31-Dec-2024
	3-42	31-Dec-2024
	3-43	31-Dec-2024
	3-44	31-Dec-2024

Ch.	Page	Date
4A	4A-9	31-Dec-2024
	4A-10	31-Dec-2024
	4A-11	31-Dec-2024
	4A-12	31-Dec-2024
	4A-13	31-Dec-2024
	4A-14	31-Dec-2024
	4A-15	31-Dec-2024
	4A-16	31-Dec-2024
	4A-17	31-Dec-2024
	4A-18	31-Dec-2024
	4A-19	31-Dec-2024
	4A-20	31-Dec-2024
	4A-21	31-Dec-2024
	4A-22	31-Dec-2024
	4A-23	31-Dec-2024
	4A-24	31-Dec-2024
	4A-25	31-Dec-2024
	4A-26	31-Dec-2024
	4A-27	31-Dec-2024
	4A-28	31-Dec-2024
	4A-29	31-Dec-2024
	4A-30	31-Dec-2024
	4A-31	31-Dec-2024
	4A-32	31-Dec-2024
	4A-33	31-Dec-2024
	4A-34	31-Dec-2024
	4A-35	31-Dec-2024
	4A-36	31-Dec-2024
	4A-37	31-Dec-2024
	4A-38	31-Dec-2024

Ch.	Page	Date
4A	4A-1	31-Dec-2024
	4A-2	31-Dec-2024
	4A-3	31-Dec-2024
	4A-4	31-Dec-2024
	4A-5	31-Dec-2024
	4A-6	31-Dec-2024
	4A-7	31-Dec-2024
	4A-8	31-Dec-2024

Ch.	Page	Date
4A	4A-39	31-Dec-2024
	4A-40	31-Dec-2024
	4A-41	31-Dec-2024
	4A-42	31-Dec-2024

Ch.	Page	Date
4B	4B-24	31-Dec-2024
	4B-25	31-Dec-2024
	4B-26	31-Dec-2024
	4B-27	31-Dec-2024
	4B-28	31-Dec-2024
	4B-29	31-Dec-2024
	4B-30	31-Dec-2024

Ch.	Page	Date
4B	4B-1	31-Dec-2024
	4B-2	31-Dec-2024
	4B-3	31-Dec-2024
	4B-4	31-Dec-2024
	4B-5	31-Dec-2024
	4B-6	31-Dec-2024
	4B-7	31-Dec-2024
	4B-8	31-Dec-2024
	4B-9	31-Dec-2024
	4B-10	31-Dec-2024
	4B-11	31-Dec-2024
	4B-12	31-Dec-2024
	4B-13	31-Dec-2024
	4B-14	31-Dec-2024
	4B-15	31-Dec-2024
	4B-16	31-Dec-2024
	4B-17	31-Dec-2024
	4B-18	31-Dec-2024
	4B-19	31-Dec-2024
	4B-20	31-Dec-2024
	4B-21	31-Dec-2024
	4B-22	31-Dec-2024
	4B-23	31-Dec-2024

Ch.	Page	Date
5	5-1	31-Dec-2024
	5-2	31-Dec-2024
	5-3	31-Dec-2024
	5-4	31-Dec-2024
	5-5	31-Dec-2024
	5-6	31-Dec-2024
	5-7	31-Dec-2024
	5-8	31-Dec-2024
	5-9	31-Dec-2024
	5-10	31-Dec-2024
	5-11	31-Dec-2024
	5-12	31-Dec-2024
	5-13	31-Dec-2024
	5-14	31-Dec-2024
	5-15	31-Dec-2024
	5-16	31-Dec-2024
	5-17	31-Dec-2024
5-18	31-Dec-2024	
5-19	31-Dec-2024	
5-20	31-Dec-2024	

Ch.	Page	Date
5	5-21	31-Dec-2024
	5-22	31-Dec-2024
	5-23	31-Dec-2024
	5-24	31-Dec-2024
	5-25	31-Dec-2024
	5-26	31-Dec-2024
	5-27	31-Dec-2024
	5-28	31-Dec-2024
	5-29	31-Dec-2024
	5-30	31-Dec-2024
	5-31	31-Dec-2024
	5-32	31-Dec-2024
	5-33	31-Dec-2024
	5-34	31-Dec-2024
	5-35	31-Dec-2024
	5-36	31-Dec-2024
	5-37	31-Dec-2024
	5-38	31-Dec-2024
	5-39	31-Dec-2024
	5-40	31-Dec-2024
5-41	31-Dec-2024	
5-42	31-Dec-2024	

Ch.	Page	Date
6	6-6	31-Dec-2024
	6-7	31-Dec-2024
	6-8	31-Dec-2024
	6-9	31-Dec-2024
	6-10	31-Dec-2024
	6-11	31-Dec-2024
	6-12	31-Dec-2024
	6-13	31-Dec-2024
	6-14	31-Dec-2024
	6-15	31-Dec-2024
	6-16	31-Dec-2024
	6-17	31-Dec-2024
	6-18	31-Dec-2024
	6-19	31-Dec-2024
	6-20	31-Dec-2024
	6-21	31-Dec-2024
	6-22	31-Dec-2024
	6-23	31-Dec-2024
	6-24	31-Dec-2024
	6-25	31-Dec-2024
	6-26	31-Dec-2024
	6-27	31-Dec-2024
	6-28	31-Dec-2024
	6-29	31-Dec-2024
	6-30	31-Dec-2024
	6-31	31-Dec-2024
	6-32	31-Dec-2024

Ch.	Page	Date
6	6-1	31-Dec-2024
	6-2	31-Dec-2024
	6-3	31-Dec-2024
	6-4	31-Dec-2024
	6-5	31-Dec-2024

Ch.	Page	Date
7	7-1	31-Dec-2024
	7-2	31-Dec-2024
	7-3	31-Dec-2024
	7-4	31-Dec-2024
	7-5	31-Dec-2024
	7-6	31-Dec-2024
	7-7	31-Dec-2024
	7-8	31-Dec-2024
	7-9	31-Dec-2024
	7-10	31-Dec-2024
	7-11	31-Dec-2024
	7-12	31-Dec-2024
	7-13	31-Dec-2024
	7-14	31-Dec-2024
	7-15	31-Dec-2024
	7-16	31-Dec-2024
	7-17	31-Dec-2024
	7-18	31-Dec-2024
	7-19	31-Dec-2024
	7-20	31-Dec-2024
	7-21	31-Dec-2024
	7-22	31-Dec-2024
	7-23	31-Dec-2024
	7-24	31-Dec-2024
	7-25	31-Dec-2024
	7-26	31-Dec-2024
	7-27	31-Dec-2024
	7-28	31-Dec-2024
	7-29	31-Dec-2024
	7-30	31-Dec-2024

Ch.	Page	Date
7	7-31	31-Dec-2024
	7-32	31-Dec-2024
	7-33	31-Dec-2024
	7-34	31-Dec-2024
	7-35	31-Dec-2024
	7-36	31-Dec-2024
	7-37	31-Dec-2024
	7-38	31-Dec-2024
	7-39	31-Dec-2024
	7-40	31-Dec-2024
	7-41	31-Dec-2024
	7-42	31-Dec-2024
	7-43	31-Dec-2024
	7-44	31-Dec-2024
	7-45	31-Dec-2024
	7-46	31-Dec-2024
	7-47	31-Dec-2024
	7-48	31-Dec-2024
	7-49	31-Dec-2024
	7-50	31-Dec-2024
	7-51	31-Dec-2024
	7-52	31-Dec-2024
	7-53	31-Dec-2024
	7-54	31-Dec-2024
	7-55	31-Dec-2024
	7-56	31-Dec-2024
	7-57	31-Dec-2024
	7-58	31-Dec-2024

Ch.	Page	Date
8	8-1	31-Dec-2024
	8-2	31-Dec-2024
	8-3	31-Dec-2024
	8-4	31-Dec-2024
	8-5	31-Dec-2024
	8-6	31-Dec-2024
	8-7	31-Dec-2024
	8-8	31-Dec-2024
	8-9	31-Dec-2024
	8-10	31-Dec-2024
	8-11	31-Dec-2024
	8-12	31-Dec-2024
	8-13	31-Dec-2024
	8-14	31-Dec-2024

Ch.	Page	Date
9	9-1	31-Dec-2024
	9-2	31-Dec-2024
	9-3	31-Dec-2024
	9-4	31-Dec-2024
	9-5	31-Dec-2024
	9-6	31-Dec-2024

| 0.5 TABLE OF CONTENTS

	Chapter
 GENERAL	1
(a non-approved chapter)	
 OPERATING LIMITATIONS	2
(an approved chapter)	
 EMERGENCY PROCEDURES	3
(a non-approved chapter)	
 NORMAL OPERATING PROCEDURES	4A
(a non-approved chapter)	
 ABNORMAL OPERATING PROCEDURES	4B
(a non-approved chapter)	
 PERFORMANCE	5
(a non-approved chapter)	
 MASS AND BALANCE / EQUIPMENT LIST	6
(a non-approved chapter)	
 DESCRIPTION OF THE AIRPLANE AND ITS SYSTEMS	7
(a non-approved chapter)	
 AIRPLANE HANDLING, CARE AND MAINTENANCE	8
(a non-approved chapter)	
SUPPLEMENTS	9

CHAPTER 1

GENERAL

		Page
1.1	INTRODUCTION	1-3
1.2	CERTIFICATION BASIS	1-5
1.3	WARNINGS, CAUTIONS AND NOTES	1-5
1.4	DIMENSIONS	1-6
	1.4.1 OVERALL DIMENSIONS	1-6
	1.4.2 WING	1-6
	1.4.3 AILERON	1-6
	1.4.4 WING FLAPS	1-6
	1.4.5 HORIZONTAL TAIL	1-6
	1.4.6 VERTICAL TAIL	1-7
	1.4.7 LANDING GEAR	1-7
1.5	DEFINITIONS AND ABBREVIATIONS	1-7
	1.5.1 AIRSPEEDS	1-7
	1.5.2 METEOROLOGICAL TERMS	1-8
	1.5.3 FLIGHT PERFORMANCE AND FLIGHT PLANNING	1-9
	1.5.4 MASS AND BALANCE (WEIGHT AND BALANCE)	1-9
	1.5.5 ENGINE	1-10
	1.5.6 DESIGNATION OF THE CIRCUIT BREAKERS	1-11
	ON THE INSTRUMENT PANEL	
	1.5.7 EQUIPMENT	1-13
	1.5.8 DESIGN CHANGE ADVISORIES	1-13
	1.5.9 MISCELLANEOUS	1-13
1.6	UNITS OF MEASUREMENT	1-14
	1.6.1 CONVERSION FACTORS	1-14
	1.6.2 CONVERSION CHART LITER / US GALLON	1-16
1.7	THREE-VIEW DRAWING	1-17

1.8 SOURCE DOCUMENTATION..... 1-18

1.8.1 ENGINE AND ENGINE INSTRUMENTS..... 1-18

1.8.2 PROPELLER..... 1-19

1.1 INTRODUCTION

This Airplane Flight Manual has been prepared in order to provide pilots and instructors with all the information required for the safe and efficient operation of the airplane.

The Airplane Flight Manual includes all the data which must be made available to the pilot according to the AWM 523 requirement. Beyond this, it contains further data and operating instructions which, in the manufacturer's opinion, could be of value to the pilot.

This Airplane Flight Manual is valid for all serial numbers. Equipment and modification level (design details) of the airplane may vary from serial number to serial number. Therefore, some of the information contained in this manual is applicable depending on the respective equipment and modification level. The exact equipment of your serial number is recorded in the Equipment Inventory in Section 6.5. The modification level is recorded in the following table (as far as necessary for this manual).

Modification	Source	Installed	
		<input type="checkbox"/> yes	<input type="checkbox"/> no
Exhaust Pipe with Muffler	MÄM 40-434 or OÄM 40-310	<input type="checkbox"/> yes	<input type="checkbox"/> no
Garmin GDL 69A SXM	OÄM 40-1000	<input type="checkbox"/> yes	<input type="checkbox"/> no
Garmin G1000 Avionics System	MÄM 40-447	<input type="checkbox"/> yes	<input type="checkbox"/> no
Garmin G1000 NXi Avionics System	MÄM 40-868	<input type="checkbox"/> yes	<input type="checkbox"/> no
Garmin G1000 NXi Phase II	MÄM 40-1007	<input type="checkbox"/> yes	<input type="checkbox"/> no
Long Range Tanks	OÄM 40-130	<input type="checkbox"/> yes	<input type="checkbox"/> no
Baggage Tray (Extended Baggage Compartment)	OÄM 40-164	<input type="checkbox"/> yes	<input type="checkbox"/> no
Baggage Tube	Basic Design	<input type="checkbox"/> yes	<input type="checkbox"/> no
Winter Baffle Fresh Air Inlet	OÄM 40-183	<input type="checkbox"/> yes	<input type="checkbox"/> no
Nose Landing Gear Tie-down	OÄM 40-200	<input type="checkbox"/> yes	<input type="checkbox"/> no
Front Seats with Adjustable Backrest	OÄM 40-252	<input type="checkbox"/> yes	<input type="checkbox"/> no
Front Seats with Adjustable Backrest - Hydrolok	OÄM 40-375	<input type="checkbox"/> yes	<input type="checkbox"/> no
Maximum Landing Mass 1280 kg	MÄM 40-574	<input type="checkbox"/> yes	<input type="checkbox"/> no

Modification	Source	Installed	
		<input type="checkbox"/> yes	<input type="checkbox"/> no
Shorter NLG Damper	MÄM 40-631	<input type="checkbox"/> yes	<input type="checkbox"/> no
Maximum Take-Off Mass 1310 kg	MÄM 40-662	<input type="checkbox"/> yes	<input type="checkbox"/> no
USB Ports	MÄM 40-1060	<input type="checkbox"/> yes	<input type="checkbox"/> no
Conventional Cockpit DA 40 NG Club	OÄM 40-321	<input type="checkbox"/> yes	<input type="checkbox"/> no
Emergency Axe	OÄM 40-326	<input type="checkbox"/> yes	<input type="checkbox"/> no
Emergency Egress Hammer	OÄM 40-401	<input type="checkbox"/> yes	<input type="checkbox"/> no
Retrofit with Autopilot KAP 140	OÄM 40-329	<input type="checkbox"/> yes	<input type="checkbox"/> no
Retrofit without Autopilot GFC 700	OÄM 40-330	<input type="checkbox"/> yes	<input type="checkbox"/> no
Short Baggage Extension	OÄM 40-331	<input type="checkbox"/> yes	<input type="checkbox"/> no
DA 40 NG without Autopilot GFC 700	OÄM 40-333	<input type="checkbox"/> yes	<input type="checkbox"/> no
Landing Gear with Large Tyres and 1280 kg Maximum Landing Mass	OÄM 40-334	<input type="checkbox"/> yes	<input type="checkbox"/> no
Diesel Operation	OÄM 40-370	<input type="checkbox"/> yes	<input type="checkbox"/> no
Engine Software VC33_1_05_19*	MÄM 40-838	<input type="checkbox"/> yes	<input type="checkbox"/> no
MD302 Standby Attitude Module	OÄM 40-1029	<input type="checkbox"/> yes	<input type="checkbox"/> no

* Or later approved software

This Airplane Flight Manual must be kept on board the airplane at all times. Its designated place is the side bag of the forward left seat.

CAUTION

The DA 40 NG is a single engine airplane. When the operating limitations and maintenance requirements are complied with, it has the high degree of reliability which is required by the certification basis. Nevertheless, an engine failure is not completely impossible. For this reason, flights during the night, on top, under instrument meteorological conditions (IMC), or above terrain which is unsuitable for a landing, constitute a risk. It is therefore highly recommended to select flight times and flight routes such that this risk is minimized.

1.2 CERTIFICATION BASIS

This airplane has been type certified in accordance with the procedures established by TCCA.
The certification basis is the Canadian Airworthiness Manual (AWM) Chapter 523, Type Certificate No. A-224.

Category of Airworthiness: NORMAL

1.3 WARNINGS, CAUTIONS AND NOTES

Special statements in the Airplane Flight Manual concerning the safety or operation of the airplane are highlighted by being prefixed by one of the following terms:

WARNING

means that the non-observation of the corresponding procedure leads to an immediate or important degradation in flight safety.

CAUTION

means that the non-observation of the corresponding procedure leads to a minor or to a more or less long term degradation in flight safety.

NOTE

draws the attention to any special item not directly related to safety but which is important or unusual.

1.4 DIMENSIONS

NOTE

All dimensions shown below are approximate.

1.4.1 OVERALL DIMENSIONS

Span	:	11.63 m	38 ft 2 in
Length	:	8.06 m	26 ft 5 in
Height	:	1.97 m	6 ft 6 in

1.4.2 WING

Airfoil	:	Wortmann FX 63-137/20 - W4	
Wing area	:	13.244 m ²	142.6 sq.ft.
Mean aerodynamic chord (MAC)	:	1.171 m	3 ft 10 in
Aspect ratio	:	10.223	
Dihedral	:	5°	
Leading edge sweep	:	1°	

1.4.3 AILERON

Area (total, left + right)	:	0.654 m ²	7.0 sq.ft.
----------------------------	---	----------------------	------------

1.4.4 WING FLAPS

Area (total, left + right)	:	1.56 m ²	16.8 sq.ft.
----------------------------	---	---------------------	-------------

1.4.5 HORIZONTAL TAIL

Area	:	2.34 m ²	25.2 sq.ft.
Elevator area	:	0.665 m ²	7.2 sq.ft.
Angle of incidence	:	-3.0° relative to longitudinal axis of airplane	

1.4.6 VERTICAL TAIL

Area	:	1.60 m ²	17.2 sq.ft.
Rudder area	:	0.47 m ²	5.1 sq.ft.

1.4.7 LANDING GEAR

Track	:	2.97 m	9 ft 9 in
Wheelbase	:	1.68 m	5 ft 6 in
Wheelbase (if MÄM 40-574 is installed)	:	1.85 m	6 ft 8 in
Nose wheel	:	5.00-5; 6 PR, TT, 120 mph	
Main wheel	:	15x6.0-6; 6 PR, TT, 160 mph	

1.5 DEFINITIONS AND ABBREVIATIONS

1.5.1 AIRSPEEDS

CAS:	Calibrated Airspeed. Indicated airspeed, corrected for installation and instrument errors. CAS equals TAS at standard atmospheric conditions (ISA) at MSL.
IAS:	Indicated Airspeed as shown on an airspeed indicator.
KCAS:	CAS in knots.
KIAS:	IAS in knots.
TAS:	True Airspeed. The speed of the airplane relative to the air. TAS is CAS corrected for errors due to altitude and temperature.
V _O :	Operating Maneuvering Speed. Full or abrupt control surface movement is not permissible above this speed.
V _{FE} :	Maximum Flaps Extended Speed. This speed must not be exceeded with the given flap setting.

V_{NE} :	Never Exceed Speed in smooth air. This speed must not be exceeded in any operation.
V_{NO} :	Maximum Structural Cruising Speed. This speed may be exceeded only in smooth air, and then only with caution.
V_R :	Rotation Speed. Speed at which the nose wheel lifts off.
V_{50} :	Speed at 50 ft (15 m) above the take-off surface.
V_S :	Stalling Speed, or the minimum continuous speed at which the airplane is still controllable in the given configuration.
V_{S0} :	Stalling Speed, or the minimum continuous speed at which the airplane is still controllable in the landing configuration.
V_X :	Best Angle-of-Climb Speed.
V_Y :	Best Rate-of-Climb Speed.

1.5.2 METEOROLOGICAL TERMS

ISA:	International Standard Atmosphere. Conditions at which air is identified as an ideal dry gas. The temperature at mean sea level is 15°C (59°F), air pressure at MSL is 1,013.25 hPa (29.92 inHg); the temperature gradient up to the altitude at which the temperature reaches -56.5°C (-69.7°F) is -0.0065°C/m (-0.00357°F/ft), and above this 0°C/m (0°F/ft).
MSL:	Mean Sea Level.
OAT:	Outside Air Temperature.
QNH:	Theoretical atmospheric pressure at MSL, calculated from the elevation of the measuring point above MSL and the actual atmospheric pressure at the measuring point.
Density Altitude:	Altitude in ISA conditions at which the air density is equal to the current air density.

Indicated Pressure Altitude:

Altitude reading with altimeter set to 1,013.25 hPa (29.92 inHg).

Pressure Altitude: Altitude above MSL, indicated by a barometric altimeter which is set to 1,013.25 hPa (29.92 inHg). The pressure altitude is the indicated pressure altitude corrected for installation and instrument errors.

In this Airplane Flight Manual altimeter instrument errors are regarded as zero.

Wind: The wind speeds which are shown as variables in the diagrams in this manual should be regarded as headwind or tailwind components of the measured wind.

1.5.3 FLIGHT PERFORMANCE AND FLIGHT PLANNING

AGL: Above ground level.

Demonstrated Crosswind Component:

The speed of the crosswind component at which adequate maneuverability for take-off and landing has been demonstrated during type certification.

MET: Weather, weather advice.

NAV: Navigation, route planning.

1.5.4 MASS AND BALANCE (WEIGHT AND BALANCE)

CG: Center of Gravity, also called **center of mass**. Imaginary point in which the airplane mass is assumed to be concentrated for mass and balance calculations. Its distance from the Datum Plane is equal to the Center of Gravity Moment Arm.

Center of Gravity Moment Arm:

The Moment Arm which is obtained if one divides the sum of the individual moments of the airplane by its total mass.

Center of Gravity Limits:

The Center of Gravity range within which the airplane, at a given mass, must be operated.

DP: Datum Plane; an imaginary vertical plane from which all horizontal distances for center of gravity calculations are measured.

Empty Mass: The mass of the airplane including unusable fuel, all operating consumables and the maximum quantity of oil.

Maximum Take-off Mass:

The maximum permissible mass for take-off.

Maximum Landing Mass:

The highest mass for landing conditions at the maximum descent velocity. This condition was used in the strength calculations to determine the landing gear loads during a particularly hard landing.

Maximum Zero Fuel Mass:

The highest permissible mass with empty fuel tanks.

Moment Arm: The horizontal distance from the Datum Plane to the Center of Gravity of a component.

Moment: The mass of a component multiplied by its moment arm.

Usable Fuel: The quantity of fuel available for flight planning.

Unusable Fuel: The quantity of fuel remaining in the tank which cannot be used for flight.

Useful Load: The difference between take-off mass and empty mass.

1.5.5 ENGINE

CT: Coolant Temperature.

EECU: Electronic Engine Control Unit.

GT: Gearbox Temperature.

LOAD:	Engine output power in percent of take-off power.
MED:	Main Engine Display.
OP:	Oil Pressure (oil pressure in the lubrication system of the engine).
OT:	Oil Temperature (oil temperature in the lubrication system of the engine).
RPM:	Revolutions per minute (rotational speed of the propeller).
SED:	Secondary Engine Display.
FT:	Fuel Temperature.

1.5.6 DESIGNATION OF THE CIRCUIT BREAKERS ON THE INSTRUMENT PANEL

ADC:	Air Data Computer.
ADF:	Automatic Direction Finder.
AHRS:	Attitude and Heading Reference System.
ANNUN:	Annunciator Panel.
AV/CDU FAN:	Avionic-, CDU-Cooling Fans.
AV. BUS:	Avionic Bus.
AUDIO:	Audio Panel / Marker Beacon Receiver.
AUTOPILOT:	Autopilot System.
COM:	COM Radio.
COM1:	COM Radio No. 1.
COM2:	COM Radio No. 2.
DG:	Directional Gyro.
DME:	Distance Measuring Equipment.

EECU A:	ECU A.
EECU B:	ECU B.
ENG INST:	Engine Instruments.
ESS TIE:	Bus Interconnection.
FAN/OAT:	Fan / Outside Air Temperature.
FLAPS:	Flap System.
FLOOD:	Flood Light.
FUEL PUMP A:	ECU A Fuel Pump.
FUEL PUMP B:	ECU B Fuel Pump.
GPS:	Global Positioning System.
GPS/NAV1:	Global Positioning System and NAV Receiver No. 1.
GPS/NAV2:	Global Positioning System and NAV Receiver No. 2.
HORIZON:	Artificial Horizon (Attitude Gyro).
INST. 1:	Engine Instrument.
INST. LT:	Instrument Lights.
LANDING:	Landing Light.
MAIN TIE:	Bus Interconnection.
MASTER CONTROL:	Master Control (Avionics Relay).
MFD:	Multi Function Display.
NAV:	NAV Receiver.
PFD:	Primary Flight Display.
PITOT:	Pitot Heating System.

POSITION:	Position Lights.
PWR:	Power.
START:	Starter.
STROBE:	Strobe Lights (= Anti Collision Lights).
T & B:	Turn and Bank Indicator.
TAS:	Traffic Advisory System.
TAXI/MAP:	Taxi Light / Map Lights.
WX500:	Stormscope.
XFR PUMP:	Fuel Transfer Pump.
XPDR:	Transponder.

1.5.7 EQUIPMENT

ELT: Emergency Locator Transmitter.

1.5.8 DESIGN CHANGE ADVISORIES

MÄM: Mandatory Design Change Advisory.

OÄM: Optional Design Change Advisory.

1.5.9 MISCELLANEOUS

ATC: Air Traffic Control.

CFRP: Carbon Fiber Reinforced Plastic.

GFRP: Glass Fiber Reinforced Plastic.

GIA: Garmin Integrated Avionics.

1.6 UNITS OF MEASUREMENT

1.6.1 CONVERSION FACTORS

Dimension	SI-Units	US Units	Conversion
Length	[mm] millimeter	[in] inch	$[mm] / 25.4 = [in]$
	[m] meter	[ft] feet	$[m] / 0.3048 = [ft]$
	[km] kilometer	[NM] nautical mile	$[km] / 1.852 = [NM]$
Volume	[l] liter	[US gal] US gallon	$[l] / 3.7854 = [US\ gal]$
		[qts] US quart	$[l] / 0.9464 = [qts]$
	[ml] milliliter	[oz] ounce	$[ml] \times 0.033814 = [oz]$
Speed	[km/h] kilometer per hour	[kt] knot	$[km/h] / 1.852 = [kt]$
		[mph] mile per hour	$[km/h] / 1.609 = [mph]$
	[m/s] meter per second	[fpm] feet per minute	$[m/s] \times 196.85 = [fpm]$
Speed of rotation	[RPM] revolutions per minute		--
Mass	[kg] kilogram	[lb] pound	$[kg] \times 2.2046 = [lb]$
Force, weight	[N] newton	[lbf] pound force	$[N] \times 0.2248 = [lbf]$
Pressure	[hPa] hectopascal	[inHg] inches of mercury	$[hPa] = [mbar]$
	[mbar] millibar		$[hPa] / 33.86 = [inHg]$
	[bar] bar	[psi] pound per square inch	$[bar] \times 14.504 = [psi]$
Temperature	[°C] degree Celsius	[°F] degree Fahrenheit	$[°C] \times 1.8 + 32 = [°F]$ $([°F] - 32) / 1.8 = [°C]$

Dimension	SI-Units	US Units	Conversion
Intensity of electric current	[A] ampère		–
Electric charge (battery capacity)	[Ah] ampère-hour		–
Electric potential	[V] volt		–
Time	[sec] second		–

1.6.2 CONVERSION CHART LITER / US GALLON

Liter	US Gallon
5	1.3
10	2.6
15	4.0
20	5.3
25	6.6
30	7.9
35	9.2
40	10.6
45	11.9
50	13.2
60	15.9
70	18.5
80	21.1
90	23.8
100	26.4
110	29.1
120	31.7
130	34.3
140	37.0
150	39.6
160	42.3
170	44.9
180	47.6

US Gallon	Liter
1	3.8
2	7.6
4	15.1
6	22.7
8	30.3
10	37.9
12	45.4
14	53.0
16	60.6
18	68.1
20	75.7
22	83.3
24	90.9
26	98.4
28	106.0
30	113.6
32	121.1
34	128.7
36	136.3
38	143.8
40	151.4
45	170.3
50	189.3

1.7 THREE-VIEW DRAWING

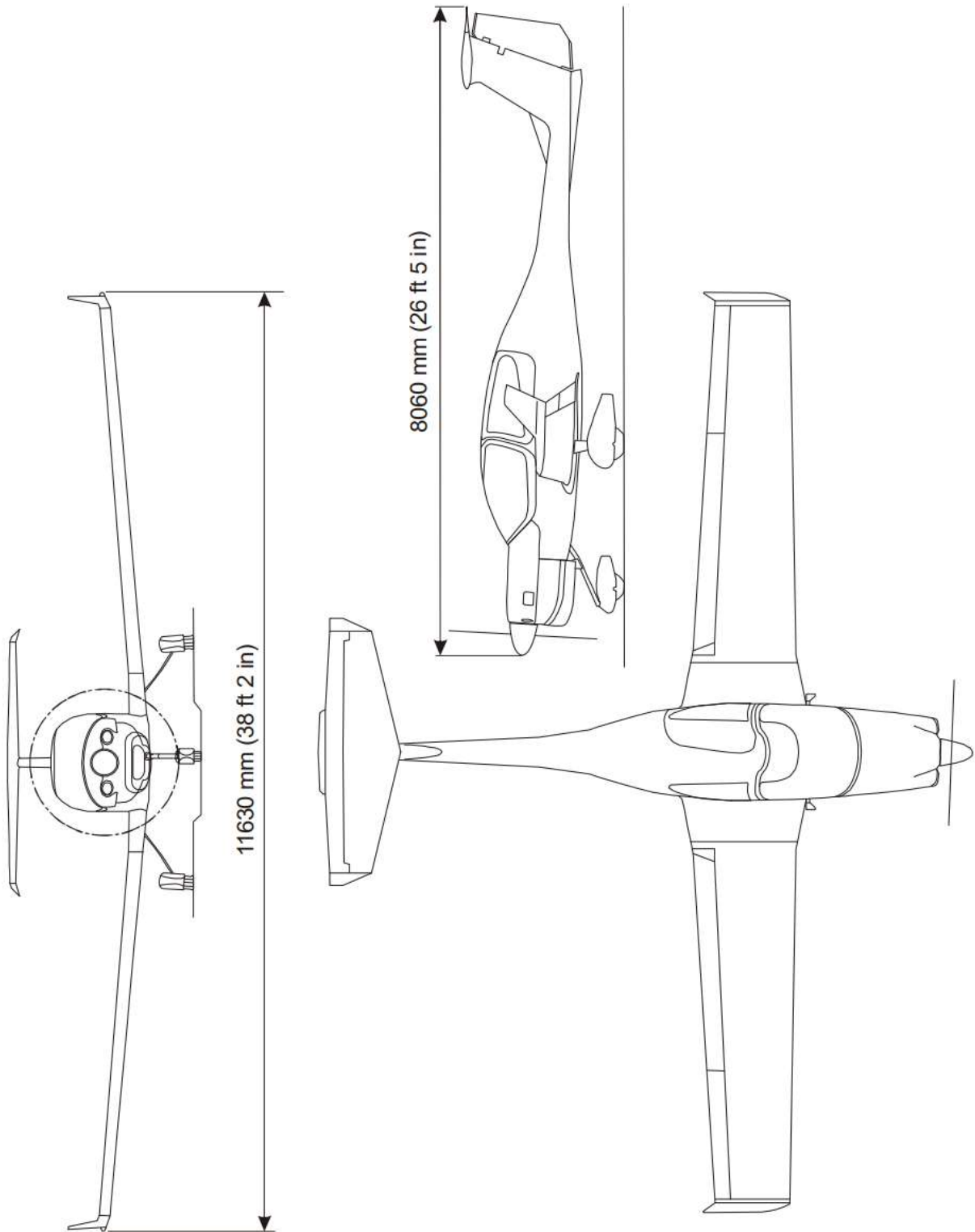

1.8 SOURCE DOCUMENTATION

This section lists documents, manuals and other literature that were used as sources for the Airplane Flight Manual, and indicates the respective publisher. However, only the information given in the Airplane Flight Manual is valid.

1.8.1 ENGINE AND ENGINE INSTRUMENTS

Address: Austro Engine GmbH
Rudolf Diesel-Str. 11
A-2700 Wiener Neustadt
AUSTRIA

Phone: +43-2622-23 000

Fax: +43-2622-23 000 - 2711

Internet: www.austroengine.at

Documents: Operation Manual AE300,
E4.01.01

Maintenance Manual AE300,
E4.08.04

Installation Manual AE300,
E4.02.01

1.8.2 PROPELLER

Address: mt-propeller
Airport Straubing Wallmühle
D-94348 ATTING
GERMANY

Phone: +49-9429-9409-0

E-mail: sales@mt-propeller.com

Internet: www.mt-propeller.de

Documents: E-124, Operation and Installation Manual
Hydraulically controlled variable pitch propeller
MTV -5, -6, -9, -11, -12, -14, -15, -16, -21, -22, -25

Intentionally left blank.

CHAPTER 2

OPERATING LIMITATIONS

	Page
2.1 INTRODUCTION	2-3
2.2 AIRSPEED	2-3
2.3 AIRSPEED INDICATOR MARKINGS	2-4
2.4 POWER-PLANT LIMITATIONS	2-4
2.5 ENGINE INSTRUMENT MARKINGS	2-9
2.6 WARNING, CAUTION, AND STATUS LIGHTS	2-10
2.6.1 COLOR AND SIGNIFICANCE OF THE WARNING	2-10
LIGHTS (RED)	
2.6.2 COLOR AND SIGNIFICANCE OF THE CAUTION	2-12
LIGHTS (AMBER)	
2.6.3 COLOR AND SIGNIFICANCE OF THE STATUS	2-13
LIGHTS (WHITE)	
2.7 MASS (WEIGHT)	2-14
2.8 CENTER OF GRAVITY	2-15
2.8.1 DATUM PLANE	2-15
2.8.2 CENTER OF GRAVITY LIMITATIONS	2-15
2.9 APPROVED MANEUVERS	2-16
2.10 MANEUVERING LOAD FACTORS	2-17
2.11 OPERATING ALTITUDE	2-17
2.12 FLIGHT CREW	2-17
2.13 KINDS OF OPERATION	2-18
2.13.1 MINIMUM OPERATIONAL EQUIPMENT (SERVICEABLE)	2-18
2.14 FUEL	2-21
2.14.1 APPROVED FUEL GRADES	2-21
2.14.2 OPERATION WITH ANTI-MICROBIAL LIFE FUEL ADDITIVES	2-22
2.14.3 OPERATION WITH ANTI-ICING FUEL ADDITIVES	2-23

2.14.4 FUEL QUANTITY	2-23
2.15 LIMITATION PLACARDS.....	2-24
2.16 OTHER LIMITATIONS.....	2-30
2.16.1 TEMPERATURE	2-30
2.16.2 BATTERY CHARGE	2-30
2.16.3 EMERGENCY SWITCH.....	2-30
2.16.4 DOOR LOCKING DEVICE.....	2-30
2.16.5 ELECTRONIC EQUIPMENT	2-31
2.16.6 SMOKING	2-31
2.16.7 USE OF THE SUN VISORS.....	2-31

2.1 INTRODUCTION

Chapter 2 of this Airplane Flight Manual includes operating limitations, instrument markings, and placards necessary for the safe operation of the airplane, its power-plant, standard systems and standard equipment.

The limitations included in this Chapter are approved.

WARNING

Operation of the airplane outside of the approved operating limitations is not permissible.

2.2 AIRSPEED

	Airspeed	KIAS	Remarks
V_O	Operating maneuvering speed	101 KIAS (up to 1080 kg / 2381 lb) 108 KIAS (above 1080 kg / 2381 lb up to 1180 kg / 2601 lb) 113 KIAS (above 1180 kg / 2601 lb)	Do not make full or abrupt control surface movement above this speed.
V_{FE}	Max. flaps extended speed	LDG: 98 KIAS T/O: 110 KIAS	Do not exceed these speeds with the given flap setting.
V_{NO} = V_C	Max. structural cruising speed	130 KIAS	Do not exceed this speed except in smooth air, and then only with caution.
V_{NE}	Never exceed speed in smooth air	172 KIAS	Do not exceed this speed in any operation.

2.3 AIRSPEED INDICATOR MARKINGS

Marking	IAS	Significance
White arc	60 KIAS - 98 KIAS	Operating range with flaps fully extended.
Green arc	66 KIAS - 130 KIAS	Normal operating range.
Yellow arc	130 KIAS - 172 KIAS	Caution range - only in smooth air.
Red line	172 KIAS	Maximum speed for all operations - V_{NE} .

2.4 POWER-PLANT LIMITATIONS

- a) Engine manufacturer : Austro Engine
- b) Engine designation : E4-A
- c) RPM limitations (shown as propeller RPM)
 - Maximum take-off (RPM) : 2300 RPM max. 5 min
 - Max. continuous power (RPM) : 2100 RPM
 - Max. overspeed : 2500 RPM max. 20 sec
- d) Engine power
 - Max. take-off power : 100% (123.5 kW) max. 5 min
 - Max. continuous power : 92% (114 kW)
- e) Oil pressure
 - Minimum at idle : 0.9 bar
 - Minimum at max. continuous conditions : 2.5 bar
 - Maximum : 6.5 bar
 - Normal range : 2.5 bar - 6.0 bar

- f) Oil quantity
- | | | |
|-------------------------|---|----------------|
| Minimum | : | 5.0 l |
| Maximum | : | 7.0 l |
| Maximum oil consumption | : | 0.1 liter/hour |
- g) Oil temperature
- | | | |
|--------------|---|----------------|
| Minimum | : | -30 °C |
| Maximum | : | 140 °C |
| Normal range | : | 50 °C - 135 °C |
- h) Gearbox temperature
- | | | |
|---------------------|---|--------|
| Minimum | : | -30 °C |
| Minimum (full load) | : | 35 °C |
| Maximum | : | 120 °C |

NOTE

A cautionary (yellow) gearbox temperature range is not imposed by the engine manufacturer. However, there is a delay between power changes and gearbox temperature. Therefore, a cautionary range has been added to the gearbox temperature instrument solely to make the pilot attentive to the gearbox temperature approaching the maximum allowable limit. There is no specific time limit associated with operating in the cautionary gearbox temperature range.

- i) Coolant temperature
- | | | |
|-----------------------|---|--------|
| Minimum (at start-up) | : | -30 °C |
| Minimum (full load) | : | 60 °C |
| Maximum | : | 105 °C |
- j) Fuel temperature
- | | | |
|---------|---|--------|
| Minimum | : | -25 °C |
| Maximum | : | 60 °C |

- k) Fuel pressure (absolute pressure)
Minimum : 4 bar

NOTE

The fuel pressure is not indicated; a fuel pressure warning will illuminate on the PFD (if G1000 is installed) or SED (if installed) if the pressure is below the limit.

- Maximum : 7 bar

NOTE

The fuel pressure is not indicated; the fuel pressure caution ECU A/B FAIL on the PFD (if G1000 is installed) or ECU A/B on the White Wire annunciator panel (if installed) will illuminate if the pressure is above the limit.

- l) Voltage
Minimum : 24.1 V
Maximum : 32.0 V
- m) Amperage
Maximum : 70 A
- n) Propeller manufacturer : mt-Propeller
- o) Propeller designation : MTV-6-R/190-69
- p) Propeller diameter : 190 cm (6 ft 3 in)
- q) Prop. pitch angle (@ 0.75 R) : Low Pitch $14.5^\circ \pm 0.2^\circ$
High Pitch $35^\circ \pm 1.0^\circ$
- r) Governor : mt- Propeller P-853-16 electrical governor

s) Oil specification :

Approved Engine Oil Types	SAE Grade
SHELL HELIX ULTRA	5W-30
ADDINOL SUPER POWER MV 0537	5W-30
BP Visco 5000	5W-30
REPSOL ELITE Common Rail	5W-30
Gulf Formula GMX	5W-30
G-Energy F Synth	5W-30
TOTAL QUARTZ 9000 ENERGY	5W-30
Gulf Formula GX	5W-30
AEROSHELL Oil Diesel Ultra	5W-30
Castrol Edge 5W-30 A3	5W-30
Castrol Edge Professional A3	5W-30
SHELL HELIX ULTRA	5W-40
LIQUI MOLY LEICHTLAUF HIGH TECH	5W-40
megol Motorenoel High Condition	5W-40
PETRONAS Syntium 3000	5W-40
LUKOIL LUXE synthetic	5W-40
Castrol Edge Professional A3	5W-40
Castrol Magnatec Professional A3	5W-40
VALVOLINE SynPower HST	5W-40
VALVOLINE SynPower	5W-40
Gulf Formula GX	5W-40
AUSTRO ENGINE Aero Produced by Liqui Moly	5W-40
Castrol SLX Professional Longtech	0W-40
Castrol Edge 0W-40 A3/B4	0W-40

Approved Engine Oil Types	SAE Grade
Castrol Edge Professional A3	0W-40
SHELL HELIX Ultra	0W-40

CAUTION

Only use the above listed engine oils for operation if conformance to the MB 229.5 specification is ensured (e.g., by a label on the oil packaging).

NOTE

It is not recommended to mix different SAE grades.

- t) Gearbox oil (propeller gearbox) : SHELL SPIRAX GSX 75W-80
SHELL SPIRAX S6 GXME 75W-80
- u) Coolant : Distilled water / Cooler protection (BASF Glyasantin Protect Plus / G48):
 - Mixture ratio 50% / 50% for freezing point -38°C (-36°F)
 - Mixture ratio 40% / 60% (MÄM 40-638 is carried out) freezing point -53°C (-63°F)

CAUTION

If the coolant or gearbox oil level is low the reason must be determined and the problem must be corrected by authorized personnel.

- v) Maximum restart altitude : 16,400 ft pressure altitude for immediate restarts
15,000 ft pressure altitude (if MÄM 40-838 or later approved software is installed) for immediate restarts
10,000 ft pressure altitude for restarts within 2 minutes

2.5 ENGINE INSTRUMENT MARKINGS

Engine instrument markings and their color code significance are shown in the table below:

Indication	Red arc/bar = lower prohibited range	Yellow arc/bar = caution range	Green arc/bar = normal operating range	Yellow arc/bar = caution range	Red arc/bar = upper prohibited range
RPM	--	--	up to 2100 RPM	2100 to 2300 RPM	above 2300 RPM
Oil pressure	below 0.9 bar	0.9 to 2.5 bar	2.5 to 6.0 bar	6.0 to 6.5 bar	above 6.5 bar
Oil temp.	below -30°C	-30° to 50°C	50° to 135°C	135° to 140°C	above 140°C
Coolant temp.	below -30°C	-30° to 60°C	60° to 100°C	100° to 105°C	above 105°C
Gearbox temp.	below -30°C	-30° to 35°C	35° to 115°C	115° to 120°C	above 120°C
Load	--	--	up to 92%	92 - 100%	--
Fuel temp.	below -25°C	-25° to -20°C	-20° to 55°C	55° to 60°C	above 60°C
Ammeter	--	--	up to 60A	60 to 70A	above 70A
Voltmeter	below 24.1V	24.1 to 25V	25 to 30V	30 to 32V	above 32V
Fuel qty.	below 1 US gal	--	1 to 14 US gal	--	--

2.6 WARNING, CAUTION AND STATUS LIGHTS

The following tables show the color and significance of the warning, caution and status alert lights. There are two variants: G1000 annunciation or SED, MED and White Wire annunciator panel.

2.6.1 COLOR AND SIGNIFICANCE OF THE WARNING LIGHTS (RED)

Warning Alerts (Red)		Meaning / Cause
G1000 installed	SED, MED, White Wire installed	
WARNING	WARNING	One of the warnings listed below is being indicated.
ENG TEMP	-	Engine coolant temperature is in the upper red range (too high / > 105 °C).
OIL TEMP	-	Engine oil temperature is in the upper red range (too high / > 140 °C).
OIL PRES	-	Engine oil pressure is in the lower red range (too low / < 0.9 bar).
L/R FUEL TEMP	-	Fuel temperature is in the upper red range (too high / > 60 °C).
GBOX TEMP	-	Engine gearbox temperature is in the upper red range (too high / > 120 °C).
FUEL PRESS	FUELPRESS	Engine fuel pressure is low.
ALTN AMPS	-	Engine alternator output is in the upper red range (too high / > 70 A).
ALTN FAIL	ALTERNATOR	Engine alternator has failed.
STARTER	START	Engine starter is engaged.

Warning Alerts (Red)		Meaning / Cause
G1000 installed	SED, MED, White Wire installed	
DOOR OPEN	DOORS	Canopy and/or rear door are/is not closed and locked.
ATTITUDE FAIL	-	Display system is not receiving attitude reference information from the AHRS; accompanied by the removal of sky/ground presentation and a red X over the attitude area.
AIRSPEED FAIL	-	Display system is not receiving airspeed input from the air data computer; accompanied by a red X through the airspeed display.
ALTITUDE FAIL	-	Display system is not receiving altitude input from the air data computer; accompanied by a red X through the altimeter display.
VERT SPEED FAIL	-	Display system is not receiving vertical speed input from the air data computer; accompanied by a red X through the vertical speed display.
HDG	-	Display system is not receiving valid heading input from the AHRS; accompanied by a red X through the digital heading display.
Red X or Yellow X	-	A red X (or yellow X, if MÄM 40-868 is installed) through any display field, such as com frequencies, nav frequencies, or engine data, indicates that display field is not receiving valid data.

2.6.2 COLOR AND SIGNIFICANCE OF THE CAUTION LIGHTS (AMBER)

Caution Alerts (Amber)		Meaning / Cause
G1000 installed	SED, MED, White Wire installed	
CAUTION	CAUTION	One of the cautions below is being indicated.
ECU A FAIL	ECU A	A fault has occurred in the engine ECU A or ECU A is being tested during FADEC-test procedure during the "Before Take-Off Check."
ECU B FAIL	ECU B	A fault has occurred in the engine ECU B or ECU B is being tested during FADEC-test procedure during the "Before Take-Off Check."
FUEL LOW	LOW FUEL	Left fuel quantity is low.
VOLTS LOW	LOW VOLTS	Engine bus voltage is too low (< 25 V).
COOL LVL	WATERLEV	Engine coolant level is low.
PITOT FAIL	PITOT	Pitot heat has failed.
PITOT HT OFF	-	Pitot heat is OFF.
LOI	-	GPS integrity is insufficient for the current phase of flight.
AHRS ALIGN: Keep Wings Level	-	The AHRS (Attitude and Heading Reference System) is aligning.
-	ENGINE	Engine limit exceeded.

2.6.3 COLOR AND SIGNIFICANCE OF THE STATUS LIGHTS (WHITE)

<u>Status Alerts (White)</u>		Meaning / Cause
G1000 installed	SED, MED, White Wire installed	
GLOW ON	GLOW	Engine glow plugs active.
FUEL XFER	FUEL TRANS	Fuel transfer from auxiliary to main tank is in progress.
PFD FAN FAIL	-	Cooling fan for the PFD is inoperative.
MFD FAN FAIL	-	Cooling fan for the MFD is inoperative.
GIA FAN FAIL	-	Cooling fan for the GIAs is inoperative.

2.7 MASS (WEIGHT)

Value	Mass (Weight)	
	kg	lb
Maximum take-off mass	1280 kg	2822 lb
Maximum take-off mass (if MÄM 40-662 is installed)	1310 kg	2888 lb
Maximum landing mass	1216 kg	2681 lb
Maximum landing mass if MÄM 40-574 is installed	1280 kg	2822 lb
Minimum flight mass	940 kg	2072 lb
Maximum zero fuel mass	1200 kg	2646 lb
Maximum zero fuel mass if MÄM 40-574 is installed	1265 kg	2789 lb
Standard:		
Max. load in baggage compartment (between rear seats and baggage frame)	30 kg	66 lb
Max. load in baggage tube compartment (if installed)	5 kg	11 lb
Max. load in short baggage extension (if OÄM 40-331 is installed)	15 kg	33 lb
Extended baggage compartment (if OÄM 40-164 is installed):		
Max. load in cockpit baggage compartment (behind rear seats)	45 kg	100 lb
Max. load in extended baggage compartment (behind cabin baggage compartment)	18 kg	40 lb
Max. load in cockpit baggage compartment and extended baggage compartment	45 kg	100 lb

WARNING

Exceeding the mass limits will lead to an overstressing of the airplane as well as to a degradation of flight characteristics and flight performance.

NOTE

In some countries the beginning of a flight is defined by starting the engine. In those countries a maximum ramp mass 4 kg (9 lb) above the maximum take-off mass is approved. At the time of lift-off the maximum permitted take-off mass must not be exceeded.

NOTE

The maximum zero fuel mass is the highest mass with empty fuel tanks.

2.8 CENTER OF GRAVITY**2.8.1 DATUM PLANE**

The Datum Plane (DP) is a plane which is normal to the airplane's longitudinal axis and in front of the airplane as seen from the direction of flight. The airplane's longitudinal axis is parallel with the upper surface of a 600:31 wedge which is placed on top of the rear fuselage in front of the vertical stabilizer. When the upper surface of the wedge is aligned horizontally, the Datum Plane is vertical. The Datum Plane is located 2.194 meter (86.38 in) forward of the most forward point of the root rib on the stub wing.

2.8.2 CENTER OF GRAVITY LIMITATIONS

The center of gravity (CG position) for flight conditions must be between the following limits:

(a) Most forward CG:

2.40 m (94.5 in) aft of DP from 940 kg to 1080 kg (2072 lb to 2381 lb)

2.46 m (96.9 in) aft of DP at 1280 kg (2822 lb)

If MÄM 40-662 is installed:

2.469 m (97.2 in) aft of DP at 1310 kg (2888 lb)

linear variation between these values

I (b) Most rearward CG:

2.53 m (99.6 in) aft of DP from 940 kg (2072 lb) to 1310 kg (2888 lb)

WARNING

Exceeding the center of gravity limitations reduces the controllability and stability of the airplane.

2.9 APPROVED MANEUVERS

I The airplane is to be operated in the Normal Category in accordance with AWM 523.

I (a) Approved Maneuvers

- 1) All normal flight maneuvers;
- 2) Stalling (with the exception of dynamic stalling); and
- 3) Lazy Eights, Chandelles, as well as steep turns and similar maneuvers, in which an angle of bank of not more than 60° is attained.

CAUTION

Aerobatics, spinning, and flight maneuvers with more than 60° of bank are not permitted in the Normal Category.

CAUTION

Intentional negative g-maneuvers are not permitted.

2.10 MANEUVERING LOAD FACTORS

WARNING

The table below shows structural limitations. Exceeding the maximum load factors will lead to an overstressing of the airplane.

CAUTION

Intentional negative g-maneuvers are not permitted.

	at v_o	at v_{NE}	with flaps in T/O or LDG position
Positive	3.8	3.8	2.0
Negative	-1.52	0	0

2.11 OPERATING ALTITUDE

The maximum operating altitude is 16,400 ft (5,000 m) pressure altitude.

2.12 FLIGHT CREW

Minimum crew : 1 (one person)

Maximum number of occupants : 4 (four persons)

2.13 KINDS OF OPERATION

Provided that national operational requirements are met, the following kinds of operation are approved:

- Daytime flights according to Visual Flight Rules (VFR)
- With the appropriate equipment: night flights according to Visual Flight Rules (NVFR)
- With the appropriate equipment: flights according to Instrument Flight Rules (IFR)
- Take-off and landing on paved surfaces
- Take-off and landing on unpaved surfaces

Flights into known or forecast icing conditions are prohibited.

Flights into known thunderstorms are prohibited.

2.13.1 MINIMUM OPERATIONAL EQUIPMENT (SERVICEABLE)

The following table lists the minimum serviceable equipment required by AWM 523. Additional minimum equipment for the intended operation may be required by national operating rules and also depends on the route to be flown.

All engine systems and equipment must be functional prior to take-off. Any engine system or equipment failure must be corrected before the next flight.

NOTE

Many of the items of minimum equipment listed in the following table are integrated in the G1000 (if installed).

	For daytime VFR flights	In addition for night VFR flights	In addition for IFR flights
Flight & Navigation Instruments	<ul style="list-style-type: none"> • Airspeed indicator • Altimeter • Magnetic compass • 1 headset, used by pilot in command 	<ul style="list-style-type: none"> • Vertical speed indicator (VSI) • Attitude gyro • Turn & bank indicator • Directional gyro • VHF radio (COM) • VOR receiver • Transponder (XPDR) • GPS receiver (part of G1000, if installed) • Second headset (if PM 1000 intercom is installed) 	<ul style="list-style-type: none"> • Second airspeed indicator (on PFD and backup, if G1000 is installed) • Second altimeter • Second attitude gyro (on PFD and backup, if G1000 is installed) • Second VHF radio (COM) • VOR-LOC-GP receiver • Second GPS receiver (part of G1000, if installed)
Engine Instruments	<ul style="list-style-type: none"> • Fuel qty. • Oil press. • Oil temp. • Coolant temp. • Coolant level indicator • Gearbox temp. • Load • Prop. RPM • Fuel temp. left & right tank • Fuel flow • Fuel pressure warning • ECU A/B Caution • ENGINE Caution (if White Wire annunciator panel is installed) 	<ul style="list-style-type: none"> • Ammeter • Voltmeter 	

	For daytime VFR flights	In addition for night VFR flights	In addition for IFR flights
Lighting		<ul style="list-style-type: none"> • Position lights • Strobe lights (anti collision lights) • Landing light • Instrument lighting • Flood light • Flashlight 	
Other Operational Minimum Equipment	<ul style="list-style-type: none"> • Stall warning system • Alternate means for fuel quantity indication (see Section 7.9) • Safety belts for each occupied seat • Airplane Flight Manual 	<ul style="list-style-type: none"> • Pitot heating system • Alternate static valve 	<ul style="list-style-type: none"> • Emergency battery (for backup attitude gyro and flood light)

NOTE

A list of approved equipment can be found in Chapter 6.

2.14 FUEL

2.14.1 APPROVED FUEL GRADES

JET A, JET A-1 (ASTM D 1655)

TS-1 (Russia, GOST 10227-86)

TS-1 (Ukraine, GSTU 320.00149943.011-99)

RT (Russia, GOST 10227-86)

RT (Ukraine, GSTU 320.00149943.007-97)

No. 3 Jet Fuel (China, GB 6537-2018)

JP-8 (F34) (USA, MIL-DTL-83133G-2010)

and blends of the above listed fuel grades.

NOTE

A minimum cetane number of 36 determined acc. to EN ISO 5165/ASTM D613 is recommended.

NOTE

Use only uncontaminated fuel from reliable sources.

2.14.2 OPERATION WITH ANTI-MICROBIAL LIFE FUEL ADDITIVES

The application of the following additives is permitted:

- BIOBOR JF : max. 270 ppm for initial treatment
max. 135 ppm for permanent use after initial treatment

CAUTION

In case of an unknown or an over dosage of the fuel additives the fuel system must be purged until the dosage is within the permitted limits.

CAUTION

Mixing different anti-microbial additives is not permitted.

NOTE

It is permitted, and in some cases recommended to run an anti-microbial and anti-icing additive at the same time.

NOTE

The specified additives are qualified for the operation with the certified fuel grades.

To clean the fuel system of the airplane a higher dosage of the specified additive is allowed under consideration of the instructions of the additive supplier. During cleaning the engine must not be operated.

NOTE

The instructions of the fuel additive supplier must be followed.

2.14.3 OPERATION WITH ANTI-ICING FUEL ADDITIVES

The use of the following fuel system icing inhibitor (FSII) additive is permitted:

Diethylene glycol monomethyl ether (DiEGME) conforming to ASTM D4171 Type III or MIL-DTL-85470B.

Concentration Limit : max. 1500 ppm

CAUTION

The use of DiEGME fuel additive is only permitted with JET A, JET A-1 (ASTM D 1655) and JP-8 (F34).

NOTE

The instructions of the fuel additive supplier, such as for brand names PRIST and DICE, must be followed.

2.14.4 FUEL QUANTITY

(a) Standard Tank Configuration:

Total fuel quantity : 2 x 15.0 US gal (2 x 56.8 liter)

Usable fuel : 2 x 14.0 US gal (2 x 53.0 liter)

(b) Long Range Tank (if installed) Configuration:

Total fuel quantity : 2 x 20.5 US gal (2 x 77.6 liter)

Usable fuel : 2 x 19.5 US gal (2 x 73.8 liter)

Max. indicated fuel quantity : 14 US gal (53 liter) per tank

Max. permissible difference : 9 US gal (approx. 34 liter)
between right and left tank

CAUTION

If an indicator shows 14 US gal, then 19.5 US gal must be assumed for the calculation of the difference between right and

left tank.

2.15 LIMITATION PLACARDS

All *limitation* placards relevant for the base DA 40 NG airplane are shown below. A list of *all* placards is included in the Airplane Maintenance Manual (Doc. No. 6.02.15), Chapter 11.

On the Instrument Panel:

THIS AIRPLANE MAY ONLY BE OPERATED IN ACCORDANCE WITH THE AIRPLANE FLIGHT MANUAL IN THE "NORMAL" CATEGORY IN NON-ICING CONDITIONS. PROVIDED THAT NATIONAL OPERATIONAL REQUIREMENTS ARE MET AND THE APPROPRIATE EQUIPMENT IS INSTALLED AND OPERATIONAL, THIS AIRPLANE IS APPROVED FOR THE FOLLOWING KINDS OF OPERATION: DAY VFR, NIGHT VFR, IFR. ALL AEROBATIC MANEUVERS INCLUDING SPINNING ARE PROHIBITED. FOR FURTHER OPERATIONAL LIMITATIONS REFER TO THE AIRPLANE FLIGHT MANUAL.

OPERATING MANEUVERING SPEED:

$V_o = 113$ KIAS (ABOVE 1180 KG / 2601 LB)

$V_o = 108$ KIAS (ABOVE 1080 KG / 2381 LB TO 1180 KG / 2601 LB)

$V_o = 101$ KIAS (UP TO 1080 KG / 2381 LB)

On the Instrument Panel, Next to the Fuel Quantity Indication:

Long Range Tank (if installed):

max. usable fuel: 2 x 19.5 US gal

- * Max. indicated fuel quantity: 2 x 14 US gal
- * Refer to AFM to use entire tank capacity
- * Max. difference LH/RH tank: 9 US gal

Next to Each of the Two Fuel Filler Necks:

WARNING
APPROVED FUEL
JET-A1
or see Airplane Flight Manual

Next to the Essential Bus Switch:

Ess. Bus NOT for normal operation. See AFM.

In the Cowling, on the Door for the Oil Filler Neck:

OIL
AUSTRO ENGINE
Aero
5W-40
or see Airplane
Flight Manual

OR

OIL
SHELL HELIX
ULTRA
5W30
or see Airplane
Flight Manual

Next to the Flap Selector Switch:

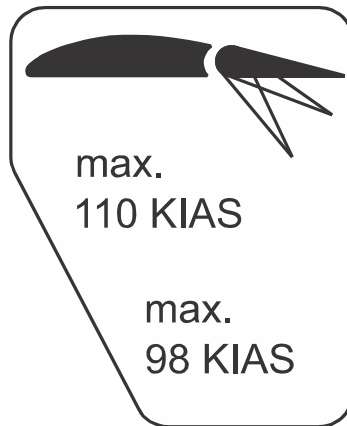

On the Fuel Valve:

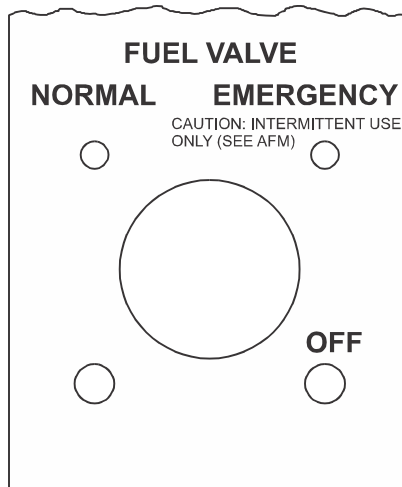

Next to the Baggage Compartment:



Baggage Tube Compartment:

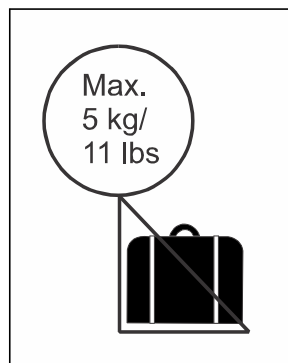

Baggage Tray (if OÄM 40-164 installed, extended baggage compartment):



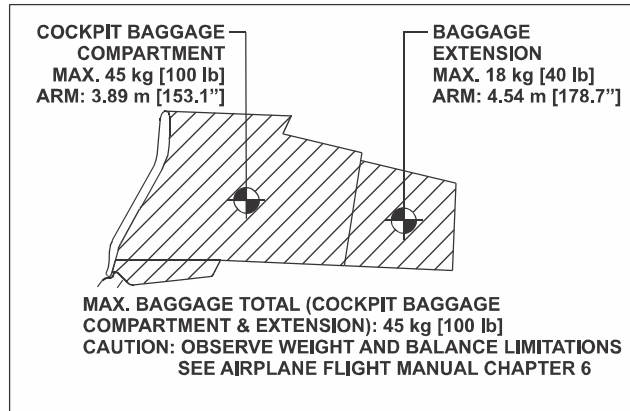

If Short Baggage Extension (OÄM 40-331) is carried out:

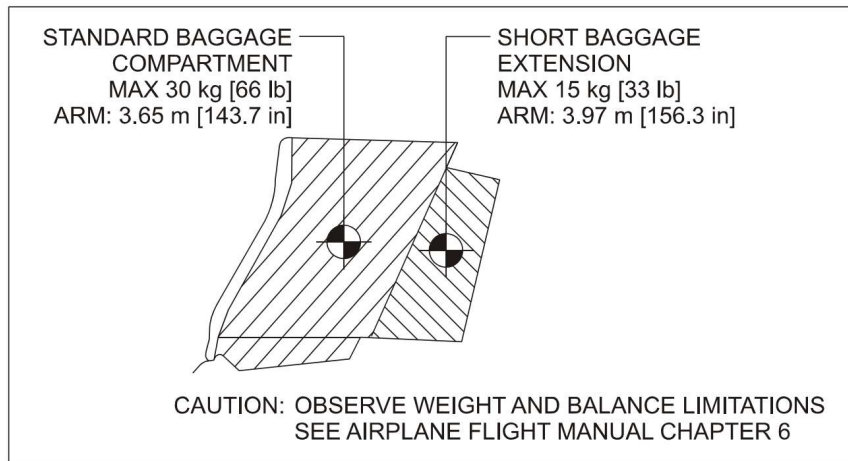

On the Left Sidewall, Next to the Instrument Panel:

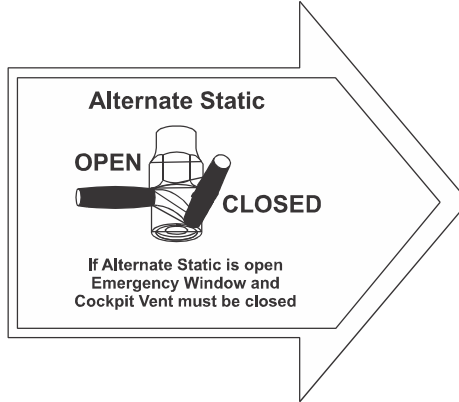

Beside the Door Locking Device:

EMERGENCY EXIT:
The keylock must be
unlocked during flight

On Fuel Cooler Inlet Baffle (if installed):

Remove at Outside
Temperatures above
20 °C / 68 °F

On the Instrument Panel:

— NO SMOKING —

2.16 OTHER LIMITATIONS

2.16.1 TEMPERATURE

The airplane may only be operated when its temperature prior to operation is not less than -40°C (-40°F).

With the airplane cold soaked and its temperature below -20°C (-4°F) the use of an external pre-heater for the engine and pilot compartment prior to operation is mandatory.

The airplane may only be operated with the fuel cooler inlet baffle installed when the outside air temperature at take-off does not exceed 20°C (68°F).

If the outside air temperature at take-off is below -30°C (-22°F) the coolant radiator inlet baffle (OÄM 40-364) must be installed. The airplane may only be operated with the coolant radiator inlet baffle, if the outside air temperature at take-off does not exceed 0°C (32°F).

With the airplane cold soaked and its temperature below -30°C (-22°F) the batteries must be pre-heated (OÄM 40-363) prior to operation.

2.16.2 BATTERY CHARGE

- █ Take-off for a Night VFR or IFR flight when the main battery charge is insufficient to start
- █ the engine is not permitted.

The use of an external power supply for engine starting with an empty airplane main battery is not permitted if the subsequent flight is intended to be a Night VFR or an IFR flight. In this case the airplane main battery must be charged first.

2.16.3 EMERGENCY SWITCH

IFR flights are not permitted when the seal on the emergency switch is broken.

2.16.4 DOOR LOCKING DEVICE

The canopy and the passenger door must not be key locked during operation of the airplane.

2.16.5 ELECTRONIC EQUIPMENT

The use and switching on of electronic equipment other than that which is part of the equipment of the airplane is not permitted, as it could lead to interference with the airplane's avionics.

Examples of undesirable items of equipment are:

- Mobile telephones
- Remote radio controls
- Video screens employing CRTs
- Minidisc recorders when in the record mode

This list is not exhaustive.

The use of laptop and handheld computers, including those with CD-ROM drives, CD and minidisc players in the replay mode, cassette players and video cameras is permitted. All this equipment however should be switched off for take-off and landing.

NOTE

Refer to FAA AC 120-76, latest approved revision, for the use of electronic equipment associated to electronic flight bag operation.

2.16.6 SMOKING

Smoking in the airplane is not permitted.

2.16.7 USE OF THE SUN VISORS

The sun visors (if installed, OÄM 40-327) may only be used during cruise. During all other phases of flight the sun visors must be locked in the fully upward position.

Intentionally left blank.

CHAPTER 3

EMERGENCY PROCEDURES

		Page
3.1	INTRODUCTION	3-3
	3.1.1 GENERAL	3-3
	3.1.2 CERTAIN AIRSPEEDS IN EMERGENCIES	3-4
3.2	INSTRUMENT INDICATIONS IN PROHIBITED (RED) RANGE	3-5
	3.2.1 ENGINE TEMPERATURE	3-5
	3.2.2 OIL TEMPERATURE	3-7
	3.2.3 OIL PRESSURE	3-9
	3.2.4 GEARBOX TEMPERATURE	3-10
	3.2.5 L/R FUEL TEMPERATURE	3-11
	3.2.6 FUEL PRESSURE	3-12
	3.2.7 ALTERNATOR AMPS	3-13
	3.2.8 ALTERNATOR FAIL	3-14
3.3	ENGINE PROBLEMS	3-15
	3.3.1 ENGINE PROBLEMS ON GROUND	3-15
	3.3.2 ENGINE PROBLEMS DURING TAKE-OFF	3-16
	3.3.3 ENGINE TROUBLESHOOTING IN FLIGHT	3-18
	3.3.4 ENGINE FAILURE IN FLIGHT	3-21
	3.3.5 RESTARTING THE ENGINE IN FLIGHT	3-22
	3.3.6 DEFECTIVE RPM REGULATING SYSTEM	3-24
	3.3.7 FUEL TRANSFER PUMP FAILURE	3-28
3.4	FAILURES IN THE ELECTRICAL SYSTEM	3-29
	3.4.1 COMPLETE FAILURE OF THE ELECTRICAL SYSTEM	3-29
	3.4.2 STARTER MALFUNCTION	3-30
3.5	SMOKE AND FIRE	3-30
	3.5.1 SMOKE AND FIRE ON GROUND	3-30
	3.5.2 SMOKE AND FIRE DURING TAKE-OFF	3-31

	3.5.3 SMOKE AND FIRE IN FLIGHT	3-34
3.6	GLIDING	3-36
3.7	EMERGENCY LANDINGS	3-37
	3.7.1 EMERGENCY LANDING WITH ENGINE OFF	3-37
	3.7.2 LANDING WITH A DEFECTIVE TIRE ON THE MAIN LANDING GEAR	3-39
	3.7.3 LANDING WITH DEFECTIVE BRAKES	3-40
3.8	RECOVERY FROM AN UNINTENTIONAL SPIN	3-41
3.9	OTHER EMERGENCIES	3-42
	3.9.1 ICING	3-42
	3.9.2 SUSPICION OF CARBON MONOXIDE CONTAMINATION	3-43
	IN THE CABIN	
	3.9.3 UNLOCKED DOORS	3-44

NOTE

Procedures for uncritical system faults are given in Chapter 4B -
ABNORMAL OPERATING PROCEDURES.

3.1 INTRODUCTION

3.1.1 GENERAL

This Chapter contains checklists as well as the description of recommended procedures to be followed in the event of an emergency. Engine failure or other airplane-related emergencies are most unlikely to occur if the prescribed procedures for pre-flight checks and airplane maintenance are followed.

If, nonetheless, an emergency does arise, the guidelines given here should be followed and applied in order to clear the problem.

As it is impossible to foresee all kinds of emergencies and cover them in this Airplane Flight Manual, a thorough understanding of the airplane by the pilot is, in addition to their knowledge and experience, an essential factor in the solution of any problems which may arise.

WARNING

In each emergency, control over the flight attitude and the preparation of a possible emergency landing have priority over attempts to solve the current problem (“first fly the aircraft”). Prior to the flight the pilot must consider the suitability of the terrain for an emergency landing for each phase of the flight. For a safe flight the pilot must constantly keep a safe minimum flight altitude. Solutions for various adverse scenarios should be thought over in advance. Thus it should be guaranteed that the pilot is at no time shocked by an engine failure and that they can act calmly and with determination.

3.1.2 CERTAIN AIRSPEEDS IN EMERGENCIES

Event		KIAS
Airspeed for best glide angle (Flaps UP)		88 KIAS
Airspeed for emergency landing with engine off	Flaps UP	83 KIAS
	Flaps T/O	78 KIAS
	Flaps LDG	77 KIAS

3.2 INSTRUMENT INDICATIONS IN PROHIBITED (RED) RANGE

3.2.1 ENGINE TEMPERATURE

Engine coolant temperature is in the upper red range (too high / above 105 °C).

Coolant temperatures above the limit value of 105 °C can lead to a total loss of power due to engine failure.

- Check for COOL LVL (if G1000 is installed) or WATERLEV (if SED is installed) caution message (low coolant level).

■ (a) COOL LVL (if G1000 is installed) or WATERLEV (if SED is installed) Caution Message Not
■ Displayed:

During climb:

- Reduce power by 10 % or more as required.
- Increase airspeed by 10 KIAS or more as required.
- If the coolant temperature does not reach the green range within 60 seconds, reduce power as far as possible and increase airspeed.

CONTINUED

During cruise:

- Reduce power, or
- Increase airspeed, if necessary by initiating a descent.
- Check coolant temperature in green range.

CAUTION

If high coolant temperature is indicated and the COOL LVL (*if G1000 is installed*) or WATERLEV (*if SED is installed*) caution message is not displayed, it can be assumed that there is no technical defect in the cooling system and that the above mentioned procedure can decrease the temperature(s). This might not be the case if the coolant temperature does not return to the green range. In this case perform a precautionary landing on the nearest suitable airfield. Prepare for an engine failure in accordance with 3.3.4 - ENGINE FAILURE IN FLIGHT.

- █ (b) COOL LVL (if G1000 is installed) or WATERLEV (if SED is installed) Caution Message
█ Displayed:

- Reduce power.
- Expect loss of coolant.

WARNING

A further increase in coolant temperature must be expected. Prepare for an engine failure in accordance with 3.3.4 - ENGINE FAILURE IN FLIGHT.

END OF CHECKLIST

3.2.2 OIL TEMPERATURE

Engine oil temperature is in the upper red range (too high / above 140 °C).

Oil temperatures above the limit value of 140 °C can lead to a total loss of power due to engine failure.

- Check oil pressure.

■ (a) If the Oil Pressure Is Outside of the Green Range (Lower Limit):

- Reduce power.
- Expect loss of engine oil.

WARNING

A further increase in oil temperature must be expected. Prepare for an engine failure in accordance with 3.3.4 - ENGINE FAILURE IN FLIGHT.

■ (b) If the Oil Pressure Is Within the Green Range:

- Reduce power.
- Increase airspeed.

CONTINUED

CAUTION

If high oil temperature is announced and the oil pressure indication is within the green range, it can be assumed that there is no technical defect in the engine oil system and that the above mentioned procedure can decrease the temperature(s). This might not be the case if the oil temperature does not return to the green range. In this case perform a precautionary landing on the nearest suitable airfield. Prepare for an engine failure in accordance with 3.3.4 - ENGINE FAILURE IN FLIGHT.

END OF CHECKLIST

3.2.3 OIL PRESSURE

Engine oil pressure is in the lower red range (too low / below 0.9 bar).

Oil pressures below the limit value of 0.9 bar can lead to a total loss of power due to engine failure.

- Reduce power.
- Expect loss of oil.

WARNING

Land at the nearest suitable airfield. Prepare for an engine failure in accordance with 3.3.4 - ENGINE FAILURE IN FLIGHT.

END OF CHECKLIST

3.2.4 GEARBOX TEMPERATURE

Engine gearbox temperature is in the upper red range (too high / above 120 °C).

Gearbox temperatures above the limit value of 120 °C can lead to a total loss of power due to engine failure.

- Reduce power.
- Increase airspeed.

CAUTION

At high ambient temperature conditions and/or at low airspeeds with high power settings, it can be assumed that there is no technical defect in the gearbox and that the above mentioned procedure will decrease the temperature(s). This might not be the case if the gearbox temperature does not return to the green range. In this case perform a precautionary landing on the nearest suitable airfield. Prepare for an engine failure in accordance with 3.3.4 - ENGINE FAILURE IN FLIGHT.

END OF CHECKLIST

3.2.5 L/R FUEL TEMPERATURE

Fuel temperature is in the upper red range (too high / above 60 °C).

Fuel temperatures above the limit value of 60 °C can lead to a noticeable reduction of the high pressure pump efficiency.

- Reduce power.
- Increase airspeed.

CAUTION

At high ambient temperature conditions and/or at low airspeeds with high power settings and low fuel quantities, it can be assumed that the above mentioned procedure will decrease the temperature(s). If the fuel temperature does not return to the green range, perform a precautionary landing on the nearest suitable airfield.

NOTE

Increased fuel temperature can occur when the fuel quantity in the main tank is low. The fuel temperature can be decreased by transferring fuel from the auxiliary to the main tank.

END OF CHECKLIST

3.2.6 FUEL PRESSURE

Engine fuel pressure is low.

- 1. Fuel quantity. check
- 2. Fuel valve. check ON
- 3. Fuel pumps ON

█ (a) If FUEL PRESS (if G1000 is installed) or FUELPRESS (if SED is installed) Warning Remains:

- 4. Fuel valve. EMERGENCY
- 5. Fuel pumps OFF

█ (b) If FUEL PRESS (if G1000 is installed) or FUELPRESS (if SED is installed) Warning Still Remains:

WARNING

Imminent engine failure must be expected. Prepare for an engine failure in accordance with 3.3.4 - ENGINE FAILURE IN FLIGHT.

END OF CHECKLIST

3.2.7 ALTERNATOR AMPS

Engine alternator output is in the upper red range (too high / above 70 A).

This warning is indicated when the consumption of electrical power is too high.

Possible reasons are:

- A fault in wiring or equipment.
 1. Electrical equipment. switch OFF as necessary and possible to reduce electric load

If the problem does not clear itself:

2. Land on the nearest suitable airfield.

END OF CHECKLIST

3.2.8 ALTERNATOR FAIL

Engine alternator has failed.

The batteries are the last remaining source of electrical power for about 30 minutes.

1. Circuit breakers check
2. ESSENTIAL BUS ON
3. Electrical equipment. switch OFF all equipment which is not needed
4. Land on the nearest suitable airfield.

WARNING

The ECU which is absolutely necessary for engine operation needs electrical power. It is recommended to switch off all electrical consumers and to land as soon as possible. Be prepared for an engine failure and an emergency landing. For a severe electrical failure an ECU backup battery system is installed.

CAUTION

For cases in which the battery capacity is not sufficient to reach a suitable airfield, an emergency battery is installed, serving as an additional back-up system for the backup attitude gyro (artificial horizon) and flood light. This battery is switched on with the EMERGENCY switch, located on the top left side of the instrument panel.

END OF CHECKLIST

3.3 ENGINE PROBLEMS

3.3.1 ENGINE PROBLEMS ON GROUND

1. POWER lever IDLE
2. Brakes as required

NOTE

If considered necessary, the engine must be shut down. Otherwise the cause of the problem must be established in order to re-establish engine performance.

CAUTION

If the oil pressure is in the red range, the engine must be shut down immediately.

WARNING

If the problem cannot be cleared, the airplane must not be flown.

END OF CHECKLIST

3.3.2 ENGINE PROBLEMS DURING TAKE-OFF

(a) Take-Off Can Still Be Aborted (Sufficient Runway Length Available)

Land Straight Ahead:

- 1. POWER lever. IDLE

On the Ground:

- 2. Brakes as required

WARNING

If sufficient time is remaining, the risk of fire in the event of a collision can be reduced as follows:

- Fuel valve OFF
- ENGINE MASTER OFF
- ELECTRIC MASTER OFF

END OF CHECKLIST

(b) Take-Off Can No Longer Be Aborted

- 1. Airspeed immediate pitch down to avoid
airspeed reduction

WARNING

If, in the event of an engine problem occurring during take-off, the take-off can no longer be aborted and a safe height has not been reached, then a straight-ahead emergency landing should be considered. Do not attempt to turn back to the airfield. Turning back can be fatal.

If Time Allows:

- 2. POWER lever check MAX
- 3. Fuel pumps check ON
- 4. VOTER switch check AUTO

WARNING

If the problem does not clear itself immediately, and the engine is no longer producing sufficient power, then an emergency landing must be carried out in accordance with 3.7.1 - EMERGENCY LANDING WITH ENGINE OFF.

END OF CHECKLIST

3.3.3 ENGINE TROUBLESHOOTING IN FLIGHT

WARNING

Control over the flight attitude has priority over attempts to solve the current problem (“first fly the airplane”).

1. Airspeed. 88 KIAS
2. POWER lever. MAX

NOTE

If the loss of power was due to unintentional setting of the POWER lever, you may adjust the friction lock and continue your flight.

■ (a) If the ECU A and ECU B Cautions Appear Simultaneously

- If the indicated LOAD remains unchanged, and
- if the perceived thrust is reduced, and
- if the engine noise level changes or the engine is running rough:
 3. POWER lever. IDLE for 1 second
 4. POWER lever. slowly increase to 1975 RPM

If the engine shows a power loss during the POWER lever increase:

5. POWER lever. IDLE for 1 second
6. POWER lever. slowly increase, stop prior to the previously observed engine power loss RPM

CONTINUED

WARNING

Do not increase the POWER lever past the propeller speed of 1975 RPM or the setting determined in step 6. An increase of engine power beyond this setting leads into another power loss.

NOTE

With this power setting the engine can provide up to 65 % load at the maximum propeller speed of 1975 RPM.

- 7. Land at the next suitable airfield.

| (b) Otherwise

Depending on the situation the following attempts can be made to restore normal engine operation:

- 3. Circuit breakers check / reset if necessary

If normal engine operation is restored continue flight and land as soon as possible.

Otherwise:

- 4. VOTER switch swap between ECU A and B

If either ECU A or B setting restores normal engine operation then maintain ECU setting and land as soon as possible.

CONTINUED

Otherwise:

- 5. VOTER switch switch back to AUTO to retain ECU redundancy

If normal engine operation is restored continue flight and land as soon as possible.

Otherwise:

- 6. Fuel valve. EMERGENCY

If normal engine operation is restored continue flight and land as soon as possible. Remain within maximum allowable lateral imbalance.

Otherwise:

- 7. Fuel valve. NORMAL
- 8. Alternate air OPEN
- 9. POWER lever. apply power as required

If normal engine operation is restored continue flight and land as soon as practicable.

If normal engine operation could not be restored by following the procedures in this section prepare for 3.3.4 - ENGINE FAILURE IN FLIGHT and land as soon as possible.

END OF CHECKLIST

3.3.4 ENGINE FAILURE IN FLIGHT

WARNING

Control over the flight attitude has priority over attempts to solve the current problem (“first fly the airplane”).

NOTE

As long as there is no major mechanical engine defect, the propeller will continue to windmill.

- 1. Airspeed 88 KIAS
- 2. Flaps UP

■ (a) If the Remaining Altitude is Sufficient for a Restart Attempt:

Try to restart the engine, refer to 3.3.5 - RESTARTING THE ENGINE IN FLIGHT.

■ (b) If the Remaining Altitude is NOT Sufficient for a Restart Attempt:

Carry out an emergency landing in accordance with 3.7.1 - EMERGENCY LANDING WITH ENGINE OFF.

END OF CHECKLIST

3.3.5 RESTARTING THE ENGINE IN FLIGHT

NOTE

With a failed engine the propeller continues to windmill. A stopped propeller indicates a major mechanical engine defect. Starter assisted restart shall not be considered.

(a) Maximum Restart Altitude:

- 16,400 ft pressure altitude for immediate restarts
- 15,000 ft pressure altitude for immediate restarts (if MÄM 40-838
or later approved software is installed)
- 10,000 ft pressure altitude for restarts within two minutes

NOTE

If the engine is allowed to cool down for more than two minutes, a successful restart may not be possible.

1. Airspeed 88 KIAS
2. POWER lever IDLE
3. VOTER switch swap between ECU A and B
If either ECU A or B setting restores normal engine operation, then maintain that ECU setting and land as soon as possible.
- Otherwise:
4. VOTER switch switch back to AUTO to retain ECU redundancy
5. Fuel valve check NORMAL
6. Alternate air as required
7. Fuel quantity check
8. Fuel transfer pump as required
9. ELECTRIC MASTER check ON
10. ENGINE MASTER check ON

CONTINUED

█ (b) If Engine Does Not Start:

- 10. Fuel valve EMERGENCY

█ (c) If Engine Does Not Start Adopt Glide Configuration:

- 11. Flaps UP
- █ 12. Carry out an emergency landing in accordance with 3.7.1 - EMERGENCY LANDING WITH ENGINE OFF.

NOTE

The glide ratio is 9.7; i.e., for every 1000 ft (305 m) of altitude loss the maximum horizontal distance traveled in still air is 1.59 NM (2.94 km). During this the propeller will continue to windmill.

█ **CAUTION**

Engine restart following an engine fire should only be attempted if it is unlikely that a safe emergency landing can be made. It must be expected that engine restart is impossible after an engine fire.

- 13. AVIONIC MASTER ON, if required

END OF CHECKLIST

3.3.6 DEFECTIVE RPM REGULATING SYSTEM

WARNING

In case of defective RPM regulating system, reduced engine performance should be anticipated.

CAUTION

Following a failure of the governor the RPM should be adjusted with the POWER lever.

CAUTION

The POWER lever should be moved slowly, in order to avoid over-speeding and excessively rapid RPM changes. The light wooden propeller blades produce more rapid RPM changes than metal blades.

(a) Oscillating RPM

- 1. Power setting change

If the Problem Does Not Clear:

- 2. VOTER switch swap between ECU A and B

If the Problem Does Not Clear:

- 3. VOTER switch AUTO
- 4. Land on the nearest suitable airfield.

END OF CHECKLIST

(b) Propeller Overspeed

CAUTION

Climb performance will be reduced.

NOTE

The propeller now works like a fixed pitch propeller. RPM is controlled by the engine power setting. Flight to the nearest airfield can be continued with a lower power setting and at a lower airspeed. Climb and go-around may not be possible under all conditions.

- 1. POWER lever reduce to not exceed 2300 RPM
- 2. Airspeed 88 KIAS
- 3. Flaps check UP

After RPM has Stabilized Below 2300 RPM:

- 4. Airspeed as required, do not exceed 2300 RPM
- 5. POWER lever as required, do not exceed 2300 RPM

If the Problem Does Not Clear:

- 6. VOTER switch swap between ECU A and B

NOTE

If selecting ECU A or ECU B does not solve the problem, switch back to AUTO. Keep controlling the climb/sink rate with the POWER lever and do not exceed 2300 RPM.

CONTINUED

If the Problem Does Not Clear:

- 7. Land on the nearest suitable airfield.

If an Increased Climb Rate is Required:

- 8. Flaps T/O position
- 9. Airspeed 72 KIAS
- 10. POWER lever as required, do not exceed 2300 RPM

END OF CHECKLIST

(c) Propeller Underspeed

1. POWER lever as required

If the Problem Does Not Clear:

2. VOTER switch swap between ECU A and B

If the Problem Does Not Clear:

3. VOTER switch AUTO
4. POWER lever as required

WARNING

Due to this problem the propeller RPM will drop. There may be no climb performance and no go-around power available.

5. Land on the nearest suitable airfield.

END OF CHECKLIST

3.3.7 FUEL TRANSFER PUMP FAILURE

- 1. Fuel quantity. check

If Main Tank Fuel Quantity Low:

- 2. Fuel valve. EMERGENCY
- 3. Fuel pumps OFF

WARNING

The fuel valve must be switched back to NORMAL before the auxiliary tank indication reads zero! Otherwise, the engine will stop during flight when the auxiliary tank is empty.

WARNING

When the fuel pump takes in air (e.g. when the fuel valve is not switched back and the auxiliary tank is empty), an inspection of the pump is necessary prior to next flight.

CAUTION

When set to EMERGENCY, fuel is transferred from the auxiliary tank to the main tank at a rate of approximately 45 US gal/h (170 liter/h).

- 4. AUX tank monitor quantity
- 5. MAIN tank monitor quantity

NOTE

AUX tank quantity must not be less than 1 US gal and MAIN tank quantity must not be more than 14 US gal.

- 6. Fuel valve. NORMAL
- 7. Land as soon as practicable.

END OF CHECKLIST

3.4 FAILURES IN THE ELECTRICAL SYSTEM

3.4.1 COMPLETE FAILURE OF THE ELECTRICAL SYSTEM

1. Circuit breakers check IN
2. ESSENTIAL BUS ON

█ (a) If There Is Still No Electrical Power Available:

- █ 3. EMERGENCY switch (if installed) ON
- █ 4. Flood light, if necessary ON
- █ 5. POWER set based on lever positions and engine noise
- █ 6. Prepare for landing with flaps in the given position. Refer to 4B.5 - FAILURES IN FLAP OPERATING SYSTEM.
- █ 7. Land on the nearest suitable airfield.

WARNING

Engine stoppage may occur, depending on the failure mode. A backup battery is installed for the ECU to provide electrical power solely to ECU B and its system for at least 30 minutes.

NOTE

█ The backup artificial horizon and the flood light will have electrical power for at least one hour.

If G1000 is installed make use of the stand-by airspeed indicator and altimeter. Engine power can be set via visual reference of the POWER lever position.

END OF CHECKLIST

3.4.2 STARTER MALFUNCTION

If the starter does not disengage from the engine after starting (Starter engaged warning (STARTER) on the G1000 (if installed) or START on the White Wire annunciator (if installed) illuminates after the engine has started):

(a) On Ground:

- 1. POWER lever. IDLE
- 2. ENGINE MASTER OFF
- 3. ELECTRIC MASTER OFF

Terminate flight preparation!

(b) In Flight:

Land as soon as possible.

END OF CHECKLIST

3.5 SMOKE AND FIRE

3.5.1 SMOKE AND FIRE ON GROUND

(a) Engine Fire When Starting on the Ground

- 1. Fuel valve. OFF
- 2. Fuel transfer pump. OFF
- 3. ENGINE MASTER OFF
- 4. Fuel pumps OFF
- 5. ELECTRIC MASTER OFF

After Standstill:

- 6. Canopy. open
- 7. Airplane evacuate immediately

END OF CHECKLIST

(b) Electrical Fire with Smoke on the Ground

1. ELECTRIC MASTER..... OFF

If the Engine Is Running:

2. POWER lever IDLE
3. ENGINE MASTER..... OFF
4. Fuel pumps OFF

When the Engine Has Stopped:

5. Canopy open
6. Airplane evacuate immediately

END OF CHECKLIST

3.5.2 SMOKE AND FIRE DURING TAKE-OFF

(a) If Take-Off Can Still Be Aborted

1. POWER lever IDLE
2. Cabin heat OFF
3. Brakes apply - bring the airplane to a stop
4. Fuel valve OFF
5. Fuel transfer pump OFF
6. ENGINE MASTER..... OFF
7. Fuel pumps OFF
8. ELECTRIC MASTER..... OFF

After Standstill:

9. Canopy open
10. Airplane evacuate immediately

END OF CHECKLIST

(b) If Take-Off Cannot Be Aborted

- 1. Cabin heat OFF
- 2. If possible, fly along a short-cut traffic circuit and land on the airfield.

WARNING

If, in the event of an engine problem occurring during take-off, the take-off can no longer be aborted and a safe height has not been reached, then a straight-ahead emergency landing should be carried out. Do not attempt to turn back to the airfield.

Turning back can be fatal. Refer to 3.3.2 - ENGINE PROBLEMS DURING TAKE-OFF.

After Climbing to a Height From Which the Selected Landing Area Can Be Reached Safely:

- 3. Fuel valve OFF
- 4. Fuel transfer pump OFF
- 5. Cabin heat OFF
- 6. ENGINE MASTER OFF
- 7. Fuel pumps OFF
- 8. ELECTRIC MASTER OFF
- 9. Emergency windows open if necessary
- 10. Carry out an emergency landing with engine off. Allow for increased landing distance due to the flap position. Refer to 3.7.1 - EMERGENCY LANDING WITH ENGINE OFF.

CONTINUED

CAUTION

In case of extreme smoke development, the front canopy may be unlatched during flight. This allows it to partially open, in order to improve ventilation. The canopy will remain open in this position. Flight characteristics will not be affected significantly.

When Airplane Has Stopped:

- 11. Canopy open
- 12. Airplane evacuate immediately

END OF CHECKLIST

3.5.3 SMOKE AND FIRE IN FLIGHT

WARNING

In the event of smoke or fire, prepare to land the airplane without delay while completing fire suppression and/or smoke evacuation procedures. If it cannot be visually verified that the fire has been completely extinguished, whether the smoke has cleared or not, land immediately.

(a) Engine Fire in Flight

- 1. Cabin heat OFF
- 2. Select appropriate emergency landing area.

When it Seems Certain That the Landing Area Will Be Reached:

- 3. Fuel valve. OFF
- 4. POWER lever. MAX
- 5. Emergency windows open if required
- 6. Land immediately. Refer to 3.7.1 - EMERGENCY LANDING WITH ENGINE OFF.

CAUTION

In case of extreme smoke development, the front canopy may be unlatched during flight. This allows it to partially open, in order to improve ventilation. The canopy will remain open in this position. Flight characteristics will not be affected significantly.

When Airplane Has Stopped:

- 7. Canopy. open
- 8. Airplane evacuate immediately

END OF CHECKLIST

(b) Electrical Fire with Smoke in Flight

- 1. EMERGENCY switch (if installed) ON
- 2. AVIONIC MASTER OFF
- 3. ELECTRIC MASTER OFF
- 4. Cabin heat OFF
- 5. Emergency windows open if required
- 6. Land immediately. Refer to 3.7.1 - EMERGENCY LANDING WITH ENGINE OFF.

WARNING

Switching OFF the ELECTRIC MASTER will lead to total failure of all electronic and electric equipment. Also affected from this is the attitude gyro (artificial horizon).

However, by switching the EMERGENCY switch ON, if installed, the emergency battery, if installed will supply power to the attitude gyro (artificial horizon) and the flood light.

In case of extreme smoke development, the front canopy may be unlatched during flight. This allows it to partially open, in order to improve ventilation. The canopy will remain open in this position. Flight characteristics will not be affected significantly.

When Airplane Has Stopped:

- 7. Canopy open
- 8. Airplane evacuate immediately

END OF CHECKLIST

3.6 GLIDING

1. Flaps UP
2. Airspeed..... 88 KIAS

NOTE

The glide ratio is 9.7; i.e., for every 1000 ft (305 m) of altitude loss the maximum horizontal distance traveled in still air is 1.59 NM (2.94 km). During this the propeller will continue to windmill.

NOTE

For operation without wheel fairings the glide ratio is reduced to 9.4; i.e., for every 1000 ft (305 m) of altitude loss the maximum horizontal distance traveled in still air is 1.54 NM (2.85 km). During this the propeller will continue to windmill.

END OF CHECKLIST

3.7 EMERGENCY LANDINGS

NOTE

For all airspeed tables in the following sections apply linear variation between weights.

3.7.1 EMERGENCY LANDING WITH ENGINE OFF

CAUTION

For emergency landing the adjustable backrests (if installed) must be fixed in the upright position.

1. Adjustable backrests (if installed) adjust to the upright position described by a placard on the roll-over bar and verify proper fixation
2. ENGINE MASTER check OFF
3. Fuel transfer pump OFF
4. Fuel pumps OFF
5. Fuel valve OFF
6. AVIONIC MASTER OFF
7. Safety harnesses check fastened and tightened

When Sure of Making Landing Area:

8. Flaps T/O or LDG, as required

NOTE

Extending the flaps to LDG will increase drag and incur a high sink rate. When the landing area can be reached safely, landing with flaps LDG is advisable.

CONTINUED

9. Approach speed see table below:

Flaps	940 kg (2072 lb)	1000 kg (2205 lb)	1080 kg (2381 lb)	1160 kg (2557 lb)	1216 kg (2681 lb)	up to 1280 kg (2822 lb)
T/O	68 KIAS	70 KIAS	73 KIAS	76 KIAS	77 KIAS	78 KIAS
LDG	66 KIAS	69 KIAS	72 KIAS	74 KIAS	76 KIAS	77 KIAS

10. ELECTRIC MASTER OFF

11. Touchdown lowest practical speed

END OF CHECKLIST

3.7.2 LANDING WITH A DEFECTIVE TIRE ON THE MAIN LANDING GEAR**CAUTION**

A defective (e.g. burst) tire is not usually easy to detect. The damage normally occurs during take-off or landing, and is hardly noticeable during fast taxiing. It is only during the roll-out after landing or at lower taxiing speeds that a tendency to swerve occurs. Rapid and determined action is then required.

1. Advise ATC.
2. Land the airplane at the edge of the runway that is located on the side of the intact tire, so that changes in direction which must be expected during roll-out due to the braking action of the defective tire can be corrected on the runway.
3. Land with one wing low. The wing on the side of the intact tire should be held low.
4. Direction should be maintained using the rudder. This should be supported by use of the brake. It is possible that the brake must be applied strongly - if necessary to the point where the wheel locks. The wide track of the landing gear will prevent the airplane from tipping over a wide speed range. There is no pronounced tendency to tip even when skidding.

END OF CHECKLIST

3.7.3 LANDING WITH DEFECTIVE BRAKES

In general, a landing on grass is recommended in order to reduce the landing run due to the greater rolling resistance.

WARNING

If sufficient time is remaining, the risk of fire in the event of a collision can be reduced as follows after a safe touch-down:

- Fuel valve OFF
- ENGINE MASTER OFF
- Fuel pumps OFF
- ELECTRIC MASTER OFF

END OF CHECKLIST

3.8 RECOVERY FROM AN UNINTENTIONAL SPIN

CAUTION

Steps 1 to 4 must be carried out **immediately** and **simultaneously**.

1. POWER lever IDLE
2. Ailerons neutral
3. Rudder full deflection against direction of spin
4. Elevator (control stick) fully forward

When Rotation Has Stopped:

5. Flaps UP
6. Rudder neutral
7. Elevator (control stick) pull carefully
8. Return the airplane from a descending into a normal flight attitude. Do not exceed the "never exceed speed," $v_{NE} = 172$ KIAS.

END OF CHECKLIST

3.9 OTHER EMERGENCIES

3.9.1 ICING

I (a) Unintentional Flight Into Icing Conditions

1. Leave the icing area (by changing altitude or turning back, in order to reach zones with a higher ambient temperature).
2. Pitot heating ON
3. Cabin heat ON
4. Cabin air. DEFROST
5. POWER lever increase power, in order to prevent
ice build-up on the propeller blades
apply power changes periodically
6. Alternate air OPEN
7. Emergency windows open if required

CAUTION

Ice build-up increases the stalling speed.

8. ATC advise if an emergency is expected

CAUTION

When the Pitot heating fails expect loss of airspeed indication.

END OF CHECKLIST

3.9.2 SUSPICION OF CARBON MONOXIDE CONTAMINATION IN THE CABIN

Carbon monoxide (CO) is a gas which is developed during the combustion process. It is poisonous and without smell. Since it occurs however usually together with flue gases, it can be detected. Increased concentration of carbon monoxide in closed spaces can be fatal. The occurrence of CO in the cabin is possible only due to a defect. If a smell similar to exhaust gases is noticed in the cabin, the following measures should be taken:

- 1. Cabin heat OFF
- 2. Ventilation open
- 3. Emergency windows open
- 4. Forward canopy unlatch, push up and lock in “Cooling Gap” position

CAUTION

The maximum demonstrated airspeed for opening the front canopy in flight is 117 KIAS.

NOTE

In case of suspicion of carbon monoxide contamination in the cabin, the front canopy may be unlatched during flight. This allows it to partially open, in order to improve ventilation. The canopy will remain open in this position. Flight characteristics will not be affected significantly.

END OF CHECKLIST

3.9.3 UNLOCKED DOORS

- 1. Airspeed. reduce immediately
- 2. Canopy. check visually if closed
- 3. Rear door. check visually if closed

I (a) Canopy Unlocked

- 4. Airspeed. below 140 KIAS
- 5. Land at next suitable airfield.

END OF CHECKLIST

I (b) Rear Door Unlocked

- 4. Airspeed. below 140 KIAS
- 5. Land at the next suitable airfield.

WARNING

Do not try to lock the rear door in flight. The safety latch may disengage and the door opens. Usually this results in a separation of the door from the airplane.

NOTE

If the rear door has been lost the airplane can be safely flown to the next suitable airfield.

END OF CHECKLIST

CHAPTER 4A

NORMAL OPERATING PROCEDURES

	Page
4A.1 INTRODUCTION	4A-3
4A.2 AIRSPEEDS FOR NORMAL OPERATING PROCEDURES	4A-3
4A.3 FLIGHT CHARACTERISTICS	4A-4
4A.4 DAILY CHECK	4A-4
4A.5 CHECKLISTS FOR NORMAL OPERATING PROCEDURES	4A-5
4A.5.1 PRE-FLIGHT INSPECTION	4A-5
4A.5.2 BEFORE STARTING ENGINE	4A-13
4A.5.3 STARTING ENGINE	4A-15
4A.5.4 BEFORE TAXIING	4A-18
4A.5.5 TAXIING	4A-20
4A.5.6 BEFORE TAKE-OFF	4A-21
4A.5.7 TAKE-OFF	4A-27
4A.5.8 CLIMB	4A-29
4A.5.9 CRUISE	4A-30
4A.5.10 FUEL TRANSFER	4A-31
4A.5.11 DESCENT	4A-32
4A.5.12 APPROACH & LANDING	4A-33
4A.5.13 GO-AROUND	4A-35
4A.5.14 AFTER LANDING	4A-36
4A.5.15 ENGINE SHUT-DOWN	4A-37
4A.5.16 POST FLIGHT INSPECTION	4A-38
4A.5.17 PARKING	4A-38
4A.5.18 FLIGHT IN RAIN	4A-39
4A.5.19 REFUELING	4A-39
4A.5.20 FLIGHT AT HIGH ALTITUDE	4A-41

Intentionally left blank.

4A.1 INTRODUCTION

Chapter 4A contains checklists and describes procedures for the normal operation of the airplane.

NOTE

Normal operating procedures for the GFC 700 are described in the Garmin G1000 Cockpit Reference Guide, P/N 190-00953-() or later, and the Garmin G1000 Pilot's Guide for the Diamond DA 40 NG, P/N 190-00952-() or later. If MÄM 40-868 is installed, normal operating procedures for the GFC 700 are described in the Garmin G1000 NXi Cockpit Reference Guide, P/N 190-02258-() or later, and the Garmin G1000 NXi Pilot's Guide for the Diamond DA 40 NG, P/N 190-02257-() or later.

4A.2 AIRSPEEDS FOR NORMAL OPERATING PROCEDURES

NOTE

For all airspeed tables in the following Sections apply linear variation between weights.

Flight Mass	940 kg (2072 lb)	1000 kg (2205 lb)	1100 kg (2425 lb)	1200 kg (2646 lb)	1280 kg (2822 lb) and above
Airspeed for rotation (Take-off run, v_R) (Flaps T/O)	56 KIAS	58 KIAS	61 KIAS	65 KIAS	67 KIAS
Airspeed for initial climb (v_{50}) (Flaps T/O)	62 KIAS	65 KIAS	67 KIAS	70 KIAS	72 KIAS

Flight Mass	940 kg (2072 lb)	1000 kg (2205 lb)	1100 kg (2425 lb)	1200 kg (2646 lb)	1280 kg (2822 lb) and above
Airspeed for take-off climb (best rate-of- climb speed v_Y) (Flaps T/O)	72 KIAS	72 KIAS	72 KIAS	72 KIAS	72 KIAS
Airspeed for cruise climb (Flaps UP)	88 KIAS	88 KIAS	88 KIAS	88 KIAS	88 KIAS
Approach speed for normal landing (Flaps LDG)	66 KIAS	72 KIAS	76 KIAS	76 KIAS	77 KIAS
Minimum speed during go-around (Flaps T/O)	72 KIAS	72 KIAS	72 KIAS	72 KIAS	72 KIAS

4A.3 FLIGHT CHARACTERISTICS

The DA 40 NG is to be flown with **the feet on the pedals**, meaning that coordinated flight in all phases and configurations shall be supported by dedicated use of the rudder and ailerons together.

4A.4 DAILY CHECK

Before the first flight of a day it must be ensured that the following checks are performed:

- On-condition check of the canopy, the rear door for cracks and major scratches.
- On-condition check of the lever arms of the canopy and the hinges of the rear door.
- Visual inspection of the locking bolts for proper movement with no backlash.
- Visual inspection of the rear door safety hook.

- Tire inflation pressure check:
 - main wheels: 3.3 bar (48 PSI)
 - nose wheel: 3.1 bar (45 PSI)
 - nose wheel (if MÄM 40-631 is carried out): 2.4 bar (35 PSI)
- Visual inspection of the spinner and its attachment (including screws).

4A.5 CHECKLISTS FOR NORMAL OPERATING PROCEDURES

4A.5.1 PRE-FLIGHT INSPECTION

(a) Cabin Check

- a) MET, NAV, Mass & CG flight planning completed
- b) Airplane documents complete and up-to-date
- c) ELECTRIC MASTER OFF, pull out key
- d) ENGINE MASTER check OFF
- e) VOTER switch check AUTO
- f) Fuel valve locked, in NORMAL position
- g) Front canopy & rear door clean, undamaged, check locking mechanism function
- h) All electrical equipment OFF
 - i) Circuit breakers check all IN (if one has popped: investigate)
 - j) POWER lever check condition, freedom of movement, full travel and friction adjustment
 - k) POWER lever IDLE
 - l) ELECTRIC MASTER ON
 - m) Fuel quantity check, use alternate mean

CONTINUED

NOTE

If the fuel quantity indicator reads 14 US gal, the correct fuel quantity must be determined with the fuel quantity measuring device. If this measurement is not carried out, the fuel quantity available for flight planning is 14 US gal.

- n) Position lights, strobe lights (ACL) check OFF
- o) Taxi lights, landing lights check OFF
- p) ELECTRIC MASTER OFF
- q) Foreign objects. check
- r) Controls and trim free and correct
- s) Emergency axe (if installed). stowed and secured
- t) Emergency egress hammer. stowed and secured
(if OÄM 40-401 is installed)
- u) Baggage. stowed and secured
- v) Fire extinguisher. charged and secured

END OF CHECKLIST

(b) Walk-Around Check, Visual Inspection

CAUTION

A visual inspection means: examination for damage, cracks, delamination, excessive play, load transmission, correct attachment and general condition. In addition control surfaces should be checked for freedom of movement.

CAUTION

In low ambient temperatures the airplane should be completely cleared of ice, snow and similar accumulations.

CAUTION

Prior to flight, remove such items as control surfaces gust lock, Pitot cover, tow bar, etc.

1. Left Main Landing Gear:

- a) Landing gear strut or fairing (if installed) visual inspection
- b) Wear, tread depth of tire check
- c) Tire, wheel, brake visual inspection
- d) Brakes check for leaks
- e) Slip marks visual inspection
- f) Chocks. remove

CONTINUED

2. Left Wing:

- a) Entire wing surface. visual inspection
- b) Step visual inspection
- c) Air intake on lower wing surface visual inspection
- d) Winter baffle of air intake on lower. consider removal depending on
wing surface (if installed) outside air temperature and verify
proper mounting
- e) Openings on lower surface check for foreign objects and for
traces of fuel (if tank is full, fuel
may spill over through the tank
vent)
- f) Tank drain drain to check for water and
sediment (drain until free of
contamination)
- g) Stall warning. check function (suction)
- h) Tank filler check closed (for fuel qty. check
use alternate means)
- i) Tank air outlet in lower surface visual inspection
- j) Pitot probe clean, orifices clear, attachment
secure (no loose or missing screws)
- k) Landing/taxi light visual inspection
- l) Winglet. visual inspection
- m) Position light, strobe light (ACL). visual inspection
- n) Tie-down check, clear
- o) 2 stall strips on wing. visual inspection
- p) Aileron and linkage. visual inspection
- q) Aileron hinges and safety pin. visual inspection

CONTINUED

- r) Foreign objects in aileron paddle visual inspection
- s) Trim tab visual inspection
- t) Flap and linkage visual inspection
- u) Flap hinges and safety pin. visual inspection
- v) Static discharger visual inspection
- w) Fuel cooler inlet baffle (if installed) verify that the outside air temperature permits the use
- x) Fuel cooler inlet baffle (if installed) check for improper mounting or obvious damage

3. Fuselage, Left Side:

- a) Canopy, left side visual inspection
- b) Door lock (if installed) unlocked, key removed
- c) Rear cabin door & window. visual inspection
- d) Fuselage skin visual inspection
- e) Antennas visual inspection
- f) Static source check for blockage

4. Empennage:

- a) Stabilizers and control surfaces. visual inspection
- b) Hinges visual inspection
- c) Elevator trim tab. visual inspection, check for movement and safety wire
- d) Rudder tab. visual inspection
- e) Tie-down check, clear
- f) Tail skid and lower fin visual inspection
- g) Static dischargers visual inspection

CONTINUED

5. *Fuselage, Right Side:*

- a) Fuselage skin visual inspection
- b) Static source check for blockage
- c) Rear window. visual inspection
- d) Canopy, right side. visual inspection

6. *Right Wing:*

- a) Flap and linkage visual inspection
- b) Flap hinges and safety pin visual inspection
- c) Aileron and linkage. visual inspection
- d) Aileron hinges and safety pin visual inspection
- e) Foreign objects in aileron paddle visual inspection
- f) Wing let visual inspection
- g) Position light, strobe light (ACL). visual inspection
- h) Tie-down check, clear
- i) Entire wing surface. visual inspection
- j) 2 stall strips on wing. visual inspection
- k) Tank air outlet in lower surface. visual inspection
- l) Tank filler visual check (for fuel qty. check use alternate means)
- m) Openings on lower surface. check for foreign objects and for traces of fuel (if tank is full, fuel may spill over through the tank vent)
- n) Tank drain drain to check for water and sediment (drain until free of contamination)
- o) Step visual inspection
- p) Static discharger visual inspection

CONTINUED

7. *Right Main Landing Gear:*

- a) Landing gear strut or fairing (if installed) visual inspection
- b) Wear, tread depth of tires check
- c) Tire, wheel, brake visual inspection
- d) Brakes check for leaks
- e) Slip marks visual inspection
- f) Chocks. remove

8. *Front Fuselage:*

- a) Engine oil level. check dipstick (inspection door on left side)

CAUTION

Do not check the engine oil level within 5 minutes after the engine has been shut down. The engine oil returns to the oil pan slowly; after 5 minutes, 80%, after 15 minutes, 90%, and after 30 minutes, 100% of the engine oil has returned to the oil pan.

Do not overfill the engine with engine oil.

- b) Gearbox oil level check visually (inspection door on left side)
- c) Cowling visual inspection
- d) 4 air intakes on front cowling check
- e) 2 air intakes on RH fuselage and cowling . . . check
- f) 1 air intake on LH fuselage check
- g) Propeller visual inspection

WARNING

Never rotate the propeller by hand.

CONTINUED

- h) Spinner including attachment screws visual inspection
- i) Nose landing gear strut visual inspection
- j) Tie-down (if installed). check, clear
- k) Tire and wheel visual inspection, check slip marks
- l) Wear, tread depth of tire check
- m) Wheel fairing (if installed). visual inspection
- n) Tow bar removed
- o) Chocks remove
- p) Exhaust visual inspection

WARNING

The exhaust can cause burns when it is hot.

9. *Underside:*

- a) Antennas visual inspection
- b) Gascolator pull down on drain to check for
water and sediment (drain until free
of contamination)
- c) Venting pipes check for blockage
- d) Fuselage underside check for excessive contamination
particularly by oil, fuel or other fluids

END OF CHECKLIST

4A.5.2 BEFORE STARTING ENGINE**CAUTION**

For take off the adjustable backrests (if installed) must be fixed in the upright position.

NOTE

The pilot must ensure that a passenger sitting on a front seat is instructed in the operation of the adjustable backrest (if installed).

1. Pre-flight inspection complete
2. Rudder pedals adjusted and locked
3. Passengers instructed
4. Adjustable backrests (if installed) adjust to the upright position described on the roll-over bar and verify proper fixation
5. Safety harnesses all fastened
6. Rear door closed and locked
7. Door lock (if installed) unlocked, key removed
8. Front canopy Position 1 or 2 (“cooling gap”)
9. Canopy lock (if installed) unlocked, key removed

CAUTION

When operating the canopy, pilots / operators are to ensure that there are no obstructions between the canopy and the mating frame, for example seat belts, clothing, etc. When operating the locking handle do NOT apply undue force.

CONTINUED

NOTE

A slight downward pressure on the canopy may be required to ease the handle operation.

10. Parking brake set
11. Flight controls free movement
12. Trim wheel T/O
13. POWER lever check IDLE
14. Friction device on POWER lever adjusted
15. Alternate air check CLOSED
16. Alternate static valve check CLOSED
17. VOTER switch check AUTO
18. Fuel pumps check OFF
19. AVIONIC MASTER check OFF
20. ELECTRIC MASTER ON
21. G1000 (if installed) wait until power-up completed. Press
ENT on MFD to acknowledge

NOTE

If the G1000 avionics system is installed, the engine instruments are only available on the MFD after item 21 has been completed.

22. White Wire annunciator panel (if installed) . . . check and press acknowledge button
23. COOL LVL caution on G1000 (if installed) . . check OFF
or WATERLEV caution SED (if installed)
24. Fuel temperature check

WARNING

Never rotate the propeller by hand.

END OF CHECKLIST

4A.5.3 STARTING ENGINE**CAUTION**

Before starting the engine and until the engine is shut down, the canopy must be closed and latched in position 1 or 2 **cooling gap** and the door must be closed and latched.

During engine operation it is prohibited to enter or exit the airplane.

CAUTION

Do not operate the engine starter motor for more than 10 seconds, because of possible overheating of the starter motor.

If the STARTER annunciation on the G1000 (if installed) or START on the White Wire annunciator panel (if installed) comes on after the engine has started and the START KEY has been released, set the ENGINE MASTER to OFF and investigate the problem.

WARNING

If the oil pressure has not moved from the red range within 3 seconds after starting, set the ENGINE MASTER switch to OFF and investigate problem.

NOTE

At low ambient temperatures it is possible that the engine will not start at the first attempt. In this case wait 60 seconds between the start attempts.

CONTINUED

- 1. Strobe lights (ACL) ON
- 2. ENGINE MASTER ON
- 3. Annunciations / GLOW ON (if G1000 check ON
is installed) or GLOW (if White Wire
annunciator panel is installed)

NOTE

GLOW ON (if G1000 is installed) or GLOW (if White Wire annunciator panel is installed) is indicated only when the engine is cold.

- 4. Annunciations / engine indications check

WARNING

Before starting the engine the pilot must ensure that the propeller area is free, and no persons can be endangered.

After the GLOW ON (if G1000 is installed) or GLOW (if White Wire annunciator panel is installed) indication is extinguished:

- 5. START KEY START as required / release when
engine has started
- 6. Annunciations / engine indications check OK/normal range

CONTINUED

7. Annunciations / STARTER (if G1000 check OFF is installed) or START (if White Wire annunciator panel is installed)
8. Annunciations / Oil pressure check OK
9. Circuit breakers check all IN
10. Idle RPM check, 710 ± 30 RPM (above 7000 ft pressure altitude idle RPM might be higher)

END OF CHECKLIST

4A.5.4 BEFORE TAXIING

- 1. AVIONIC MASTER ON
- 2. Power lever as required, max. 50% if engine temperature below green range
- 3. Electrical equipment. ON as required
- 4. Flight instruments and avionics set as required
- 5. Flood light ON, test function, as required
- 6. Pitot heating ON, check annunciation and observe an increase in alternator load
- 7. Pitot heating OFF
- 8. Strobe lights (ACLs). check ON
- 9. Position lights, landing and taxi lights. as required

CAUTION

When taxiing at close range to other airplanes, or during night flight in clouds, fog or haze, the strobe lights should be switched OFF. The position lights must always be switched ON during night flight.

- 10. Primary flight display (PFD) (if G1000. NO AUTOPILOT ANNUNCIATIONS and autopilot GFC 700 are installed)
- 11. Autopilot disconnect tone (if autopilot NOTE GFC 700 is installed)

CONTINUED

NOTE

If the G1000 avionics system and the autopilot GFC 700 are installed, the AFCS automatically conducts a preflight self-test upon initial power application. The preflight test is indicated by a white boxed PFT on the PFD. Upon successful completion of the preflight test, the PFT is removed, the red AFCS annunciation is removed, and the autopilot disconnect tone sounds. If AFCS annunciation remains on or a failure of the preflight test is indicated terminate flight preparation and investigate the problem.

- 12. MANUAL ELECTRIC TRIM - TEST as follows (if G1000 and autopilot GFC 700 are installed):

Press the AP DISC button down and hold while commanding trim.
Manual electric trim should not operate either nose up or nose down.

- 13. AUTOPILOT (if G1000 and autopilot. engage by pressing AP button GFC 700 are installed)
- 14. AP DISC switch (if G1000 and autopilot press. Verify that the autopilot GFC 700 are installed) disconnects, check tone
- 15. TRIM set to take-off position manually

END OF CHECKLIST

4A.5.5 TAXIING

1. Parking brake release
2. Brakes test
3. Flight instrumentation and avionics check for correct indications
4. Fuel pumps check OFF

CAUTION

When taxiing on a poor surface select the lowest possible RPM to avoid damage to the propeller from stones or similar items.

CAUTION

Avoid prolonged permanent braking while taxiing. Prolonged permanent braking while taxiing will overheat the brakes and may cause loss of brake capacity and subsequent damage to the airplane.

END OF CHECKLIST

4A.5.6 BEFORE TAKE-OFF

CAUTION

For take-off the adjustable backrests (if installed) must be fixed in the upright position.

- 1. Position airplane into wind if possible.
- 2. Parking brake set
- 3. Adjustable backrests (if installed) verify upright position and proper fixation
- 4. Safety harnesses fastened
- 5. Rear door check closed and locked

CAUTION

When operating the canopy, pilots/operators must ensure that there are no obstructions between the canopy and the mating frame, for example seat belts, clothing, etc. When operating the locking handle do NOT apply undue force.

A slight downward pressure on the canopy may be required to ease the handle operation.

- 6. Front canopy closed and locked
- 7. Door warning (DOOR OPEN (if G1000 check no indication is installed) DOORS (if White Wire annunciator panel is installed)
- 8. Annunciations / engine indications check OK / normal range (except oil pressure may be in the yellow range with a warm engine and POWER lever set to IDLE)
- 9. Circuit breakers check pressed in
- 10. Longitudinal trim set T/O

CONTINUED

- 11. Fuel valve check NORMAL
- 12. FLAPS check function & indicator / set T/O
- 13. Flight controls unrestricted free movement, correct sense
- 14. Pitot heating ON, if required
- 15. Landing light ON, if required

I (a) ECU / Fuel Pump Test Sequence:

CAUTION

If the ECU A/B FAIL (if G1000 is installed) or ECU A/B (if White Wire annunciator panel is installed) indicators do not illuminate during the test sequence there is a malfunction in the engine control system. Terminate flight preparation.

The whole test procedure must be completed without any error (ECU A/B FAIL (if G1000 is installed) or ECU A/B (if White Wire annunciator panel is installed) extinguished after test completion). In case the test procedure aborts with an error indication (one or both ECU A/B FAIL (if G1000 is installed) or ECU A/B (if White Wire annunciator panel is installed) indicators remain ON) terminate flight preparation, even if the engine seems to run smoothly after the test procedure.

CAUTION

During the test sequence the engine will produce thrust therefore the parking brake must be set.

CONTINUED

NOTE

The engine oil / gearbox temperature has to be in the green range before starting the test sequence. Efficient engine warm up may require higher power settings (max. 50% engine power). Releasing the ECU TEST BUTTON or manipulating the POWER lever before the test sequence is completed will abort the test sequence. During the following ECU and fuel pump test, a shake of the engine might occur.

1. POWER lever IDLE
2. Propeller RPM check below 1000 RPM
3. Fuel pumps check OFF
4. VOTER switch check AUTO

NOTE

If the VOTER switch is not in the AUTO position, the ECU test will not start.

5. All engine temperatures. check in the green range
6. Parking brake check set
7. ECU TEST button press and hold

NOTE

The ECU test consists of the following sequence: the propeller RPM will increase to above 1800 RPM. This is followed by a slight RPM drop, then a recovery before returning to idle RPM. At this point the ECU switches back to the other ECU channel and the sequence is repeated. At the end of the test, the control of the engine is returned to the initially active ECU channel. A slight shake of the engine may occur during ECU switching.

CONTINUED

- 8. ECU A/B FAIL (if G1000 is installed) verify both OFF
or ECU A/B (if White Wire annunciator
panel is installed) lights

Test sequence completed.

- 9. ECU TEST button release

NOTE

By switching between ECU A and B the two independent electrical fuel pumps are switched over as well.

- 10. VOTER switch ECU A
- 11. Engine check running without a change (shake
may occur)
- 12. VOTER switch AUTO
- 13. Engine check running without a change (shake
may occur)
- 14. VOTER switch ECU B
- 15. Engine check running without a change (shake
may occur)
- 16. VOTER switch AUTO

CAUTION

Running the engine with the VOTER switch on ECU A or ECU B, other than for this test or in an emergency is prohibited. The engine control system redundancy is only given with the VOTER switch set to AUTO.

CONTINUED

(b) Available Power Check:

1. POWER lever MAX for 10 seconds
2. Annunciations check OK / normal range
3. Instruments check within normal range
4. RPM. stabilizes at 2200 to 2300 RPM, min.
2100 RPM below -10°C (14°F)
5. LOAD indication. stabilizes at 88% to 100%

CAUTION

The load indications in the table below are minimum values to be indicated with the airplane stationary in no wind conditions. If the engine does not stabilize at the target RPM and the required load indication, terminate flight preparation.

Altitude [ft]	OAT								
	-35°C -31°F	-20°C -4°F	-10°C 14°F	0°C 32°F	10°C 50°F	20°C 68°F	30°C 86°F	40°C 104°F	50°C 122°F
0	94%						95%	92%	90%
2000	94%						95%	92%	/
4000	96%						95%	92%	/
6000	96%						95%	92%	/
8000	96%						95%	94%	91%
10000	96%			94%	93%	91%	88%	/	/

CONTINUED

- 6. POWER lever IDLE
- 7. Engine instruments check in green range

NOTE

With the POWER lever in IDLE the oil pressure may be in the low yellow range. This is acceptable to continue flight.

- 8. Fuel pumps ON
- 9. Parking brake release

END OF CHECKLIST

4A.5.7 TAKE-OFF

(a) Normal Take-Off Procedure

- 1. Transponder as required
- 2. POWER lever MAX

WARNING

The proper performance of the engine at MAX should be checked early in the take-off procedure, so that the take-off can be aborted if necessary.

- 3. Elevator neutral
- 4. Rudder maintain direction

NOTE

In strong crosswinds steering can be augmented by use of the toe brakes. It should be noted, however, that this method increases the take-off roll, and should not generally be used.

NOTE

For soft field take-off hold elevator back pressure during take-off roll until nose lift-off. Accelerate to initial climb speed after lift-off.

- 5. Nose wheel lift-off (v_R) see table below:

940 kg (2072 lb)	1000 kg (2205 lb)	1100 kg (2425 lb)	1200 kg (2646 lb)	1280 kg (2822 lb) and above
56 KIAS	58 KIAS	61 KIAS	65 KIAS	67 KIAS

CONTINUED

NOTE

A spurious activation of the stall warning during take-off in crosswind conditions, operation on unpaved surfaces and gusty conditions may occur.

6. Airspeed for initial climb see table below:

940 kg (2072 lb)	1000 kg (2205 lb)	1100 kg (2425 lb)	1200 kg (2646 lb)	1280 kg (2822 lb) and above
62 KIAS	65 KIAS	67 KIAS	70 KIAS	72 KIAS

Above a Safe Height:

- 7. Landing light OFF
- 8. Fuel pumps OFF
- 9. POWER lever reduce to 92% load

END OF CHECKLIST

4A.5.8 CLIMB

| (a) Procedure for Take-Off Climb

- 1. Flaps T/O
- 2. Airspeed 72 KIAS
- 3. POWER lever 92% or maximum 2100 RPM
- 4. Annunciations / engine indications monitor
- 5. Rudder..... as required

CAUTION

If the oil temperature and/or coolant temperature reaches the yellow range during climb, flight should be continued with an airspeed increased by 5 kt and power reduced by 10 % (reduced climb rate) for better engine cooling.

NOTE

Operating in the gearbox cautionary range is permitted. However, prolonged operation is not recommended.

END OF CHECKLIST

| (b) Cruise Climb

- 1. Flaps UP
- 2. Airspeed 88 KIAS
- 3. POWER lever 92% or maximum 2100 RPM
- 4. Annunciations / engine indications monitor
- 5. Rudder..... as required

END OF CHECKLIST

4A.5.9 CRUISE

1. Flaps UP
2. POWER lever up to 92% or maximum 2100 RPM
3. Trim as required
4. Fuel transfer repeat as required (in accordance with 4A.5.10 - FUEL TRANSFER)

NOTE

The engine manufacturer recommends a cruise power setting of 75 %.

NOTE

Proper operation of the transfer pump must be checked by monitoring the fuel quantities (increasing in the MAIN tank, decreasing in the AUX tank, approx. 1 US gal per minute).

END OF CHECKLIST

4A.5.10 FUEL TRANSFER

CAUTION

During normal operation fuel is taken from the main tank only. Therefore fuel must be transferred from the auxiliary tank to the main tank by activating the fuel transfer pump. The transfer rate is approximately 60 US gal/h (227 liter/h).

1. Fuel transfer switch ON

NOTE

The transfer pump turns off automatically to avoid overfilling the main tank. The switch remains in its position. If the pump is not turned off, it will continue pumping each time the fuel level in the main tank drops, but only as long as there is fuel in the auxiliary tank. The fuel transfer status light is illuminated only while the pump is running.

2. Fuel transfer switch OFF, if required

NOTE

If the fuel transfer status light starts to blink, the fuel transfer pump must be switched off.

END OF CHECKLIST

4A.5.11 DESCENT

1. POWER lever. as required
2. Airspeed. as required
3. Trim as required
4. Annunciations / engine indications. monitor

END OF CHECKLIST

4A.5.12 APPROACH & LANDING

I (a) Approach:

NOTE

If MÄM 40-574 is NOT carried out, a landing with a mass between 1216 kg (2681 lb) and 1280 kg (2822 lb) constitutes an abnormal operating procedure. Refer to Section 4B.7 - LANDING WITH HIGH LANDING MASS.

CAUTION

For landing the adjustable backrests (if installed) must be fixed in the upright position.

- 1. Adjustable backrests (if installed) adjust to the upright position described by a placard on the roll-over bar and verify proper fixation
- 2. Safety harnesses check fastened and tightened
- 3. Controls no interference by foreign objects
- 4. Landing light as required
- 5. Fuel pumps ON
- 6. Parking brake check released
- 7. Trim as required

CONTINUED

(b) Before Landing

8. Airspeed. see table below:

Flaps	940 kg (2072 lb)	1000 kg (2205 lb)	1100 kg (2425 lb)	1200 kg (2646 lb)	1216 kg (2681 lb)	1280 kg (2822 lb)
T/O	68 KIAS	70 KIAS	74 KIAS	77 KIAS	77 KIAS	78 KIAS
LDG	66 KIAS	68 KIAS	72 KIAS	76 KIAS	76 KIAS	77 KIAS

9. FLAPS as required

10. POWER lever. as required

11. Trim as required

12. Final approach speed see table below:

Flaps	940 kg (2072 lb)	1000 kg (2205 lb)	1100 kg (2425 lb)	1200 kg (2646 lb)	1216 kg (2681 lb)	1280 kg (2822 lb)
LDG	66 KIAS	68 KIAS	72 KIAS	76 KIAS	76 KIAS	77 KIAS

NOTE

Higher approach speeds result in a significantly longer landing distance during flare.

CAUTION

In conditions such as (e.g.) strong wind, danger of wind shear or turbulence a higher approach speed should be selected.

END OF CHECKLIST

4A.5.13 GO-AROUND

1. POWER lever MAX
2. Airspeed 72 KIAS
3. Flaps T/O

Above a Safe Height:

4. Airspeed 88 KIAS
5. Flaps UP

END OF CHECKLIST

4A.5.14 AFTER LANDING

1. POWER lever IDLE
2. Brakes as required
3. Transponder OFF / STBY
4. Pitot heating OFF
5. Avionics as required
6. Lights as required
7. Flaps UP
8. Fuel pumps OFF

END OF CHECKLIST

4A.5.15 ENGINE SHUT-DOWN

1. Parking brake set
2. POWER lever up to 10 % load for 1 minute
3. Engine indications check
4. ELT check not transmitting on 121.5 MHz
5. AVIONIC MASTER OFF
6. Electrical consumers OFF
7. ENGINE MASTER OFF
8. Strobe OFF

CAUTION

After turning the ENGINE MASTER OFF, wait until the engine indications on the G1000 MFD (if installed) are red X'd or yellow X'd, or the engine indications on the MED (if installed) disappear prior to switching the ELECTRIC MASTER OFF. This ensures that engine and flight data can be written to non-volatile memory before removing electrical power.

9. ELECTRIC MASTER OFF

CAUTION

Do not shut down an engine by placing the FUEL VALVE in the OFF position. The high pressure fuel pump can otherwise be damaged.

NOTE

Before shut-down the engine must run for at least 1 minute with the POWER lever set up to 10% load to avoid heat damage of the turbo charger.

END OF CHECKLIST

4A.5.16 POST FLIGHT INSPECTION

1. Record any problem found in flight and during the post-flight check in the log book.
2. Park the airplane.
3. If necessary, moor the airplane.

END OF CHECKLIST

4A.5.17 PARKING

1. Parking brake release, use chocks
2. Airplane moor, if unsupervised for extended
period
3. Pitot probe cover

END OF CHECKLIST

4A.5.18 FLIGHT IN RAIN**NOTE**

Performance deteriorates in rain; this applies particularly to the take-off distance and to the maximum horizontal speed. The effect on the flight characteristics is minimal. Flight through very heavy rain should be avoided because of the associated visibility problems.

4A.5.19 REFUELING**CAUTION**

Before refueling, the airplane must be connected to electrical ground. Grounding points: unpainted areas on steps, left and right.

■ (a) Use of Fuel Additives:**CAUTION**

Only approved fuel additives not exceeding the approved concentrations may be used; refer to Section 2.14 - FUEL. The instructions of the fuel additive supplier must be followed. Failure to exactly follow the fuel additive mixing procedures during refueling can result in incorrect fuel additive concentrations, fuel system contamination and possible engine stoppage.

Fuel additives may have been already mixed into the fuel when stored. In this case make sure that the brand is approved and the concentration does not exceed the approved values.

Anti-microbial life fuel additives may be manually batch-blended into the fuel tanks. In this case introduce the additive while filling the tank after approximately the half tank is filled.

Anti-icing fuel additives should not be batch-blended into the fuel tank. The fuel additive should be injected into a stream of fuel.

Record the brand and amount of fuel additives in the airplane log every time fuel additives are added.

█ (b) Typical Dosing Quantities:

█ BIOBOR JF

Fuel Quantity				Fuel Additive BIOBOR JF*			
				135 ppm		270 ppm	
Liter	US gal	kg	lb	ml	oz	ml	oz
50	13.2	40.2	88.68	5.2	0.18	10.4	0.35
100	26.4	80.4	177.37	10.4	0.35	20.9	0.71
150	39.6	120.6	266.05	15.6	0.53	31.3	1.06

* Calculation according to SB No. 982, **Instructions for use of BIOBOR JF**

█ DiEGME (ASTM D4171 Type III or MIL-DTL-85470B)

Fuel Quantity				Fuel Additive*, ** DiEGME (1250 ppm)	
Liter	US gal	kg	lb	ml	oz
50	13.2	40.2	88.6	62.5	2.11
100	26.4	80.4	177.2	125.0	4.23
150	39.6	120.6	265.9	187.5	6.34

* Densities used for calculation: Fuel: 0.804 kg/l, DiEGME: 1.05 kg/l
 ** Do not batch blend

4A.5.20 FLIGHT AT HIGH ALTITUDE

At high altitudes the provision of oxygen for the occupants is necessary. Legal requirements for the provision of oxygen should be adhered to.

Also see Section 2.11 - OPERATING ALTITUDE.

Intentionally left blank.

CHAPTER 4B

ABNORMAL OPERATING PROCEDURES

	Page
4B.1 PRECAUTIONARY LANDING	4B-3
4B.2 INSTRUMENT INDICATIONS OUTSIDE OF GREEN RANGE	4B-5
4B.2.1 RPM	4B-5
4B.2.2 COOLANT TEMPERATURE	4B-6
4B.2.3 OIL TEMPERATURE	4B-7
4B.2.4 OIL PRESSURE	4B-8
4B.2.5 GEARBOX TEMPERATURE	4B-9
4B.2.6 FUEL TEMPERATURE	4B-10
4B.2.7 VOLTAGE	4B-11
4B.2.8 CURRENT	4B-12
4B.3 CAUTION ALERTS	4B-13
4B.3.1 ECU A FAILURE	4B-13
4B.3.2 ECU B FAILURE	4B-15
4B.3.3 FUEL QUANTITY LOW	4B-17
4B.3.4 COOLANT LEVEL	4B-19
4B.3.5 PITOT HEATING FAILURE	4B-20
4B.3.6 ENGINE CAUTION (IF WHITE WIRE ANNUNCIATOR	4B-20
PANEL IS INSTALLED)	
4B.4 CANOPY IN COOLING GAP POSITION	4B-21
4B.5 FAILURES IN FLAP OPERATING SYSTEM	4B-22
4B.5.1 FAILURE IN POSITION INDICATION OR FUNCTION	4B-22
4B.5.2 MODIFIED APPROACH PROCEDURE DEPENDING ON	4B-22
THE AVAILABLE FLAP SETTING	
4B.6 LIGHTNING STRIKE	4B-24
4B.7 LANDING WITH MASS ABOVE MAXIMUM LANDING MASS	4B-25

	4B.8	STARTING ENGINE WITH EXTERNAL POWER	4B-26
		4B.8.1 BEFORE STARTING ENGINE	4B-26
		4B.8.2 STARTING ENGINE	4B-28
	4B.9	ERRONEOUS INDICATIONS OF AIRSPEED OR ALTITUDE	4B-30

4B.1 PRECAUTIONARY LANDING

NOTE

A landing of this type is only necessary when there is a reasonable suspicion that due to operational factors such as fuel shortage, weather conditions, etc. the possibility of endangering the airplane and its occupants by continuing the flight cannot be excluded. The pilot is required to decide whether or not a controlled landing in a field represents a lower risk than the attempt to reach the nearest airfield under all circumstances.

NOTE

If no level landing area is available, a landing on an upward slope should be sought.

1. Select appropriate landing area.
2. Consider wind.
3. Approach: If possible, the landing area should be overflown at a suitable height in order to recognize obstacles. The degree of offset at each part of the circuit will allow the wind speed and direction to be assessed.
4. ATC advise

■ Perform procedures according to Normal Operating Procedure 4A.5.12 - APPROACH & LANDING.

5. Touchdown with the lowest possible airspeed

CONTINUED

CAUTION

If sufficient time is remaining, the risk of fire in the event of a collision with obstacles can be reduced as follows after a safe touch-down:

- 6. ENGINE MASTER OFF
- 7. Fuel valve. OFF
- 8. ELECTRIC MASTER OFF

END OF CHECKLIST

4B.2 INSTRUMENT INDICATIONS OUTSIDE OF GREEN RANGE

4B.2.1 RPM

I (a) High RPM

1. Reduce power.
2. Keep RPM within the green range using the POWER lever.

NOTE

An RPM in the yellow range is permissible for up to 5 minutes if required, e.g. for go-around or take-off.

If the above mentioned measures do not solve the problem refer to Section 3.3.6 - DEFECTIVE RPM REGULATING SYSTEM.

3. Land at the nearest suitable airfield.

END OF CHECKLIST

4B.2.2 COOLANT TEMPERATURE(a) High Coolant Temperature

Proceed according to Section 3.2.1 - ENGINE TEMPERATURE.

(b) Low Coolant Temperature

- Check for COOL LVL (if G1000 is installed) or WATERLEV (if SED is installed) caution message (low coolant level).

NOTE

During an extended descent from high altitudes with a low power setting coolant temperature may decrease. In this case an increase in power and a decrease in airspeed can help.

COOL LVL (if G1000 is installed) or WATERLEV (if SED is installed) Caution Message Displayed:

- Reduce power.
- Expect loss of coolant.

WARNING

A further decrease in coolant temperature must be expected. Prepare for an engine failure in accordance with Section 3.3.3 - ENGINE TROUBLESHOOTING IN FLIGHT.

END OF CHECKLIST

4B.2.3 OIL TEMPERATURE(a) High Oil Temperature

Proceed according to Section 3.2.2 - OIL TEMPERATURE.

(b) Low Oil Temperature**NOTE**

During an extended descent from high altitudes with a low power setting oil temperature may decrease. In this case an increase in power can help.

- Increase power.
- Reduce airspeed.

END OF CHECKLIST

4B.2.4 OIL PRESSURE**I** (a) High Oil Pressure

- Check oil temperature.
- Check coolant temperature.

If the temperature is within the green range:

- Expect false oil pressure indication. Keep monitoring temperatures.

If the temperature is outside of the green range:

- Reduce power on engine.

WARNING

Land at the nearest suitable airfield. Prepare for an engine failure in accordance with 3.7.1 - EMERGENCY LANDING WITH ENGINE OFF.

NOTE

At low oil temperature high oil pressure may occur which could lead to an oil pressure warning. In this case reduce the power setting until the warning disappears and conduct the warm up with this reduced setting.

END OF CHECKLIST

4B.2.5 GEARBOX TEMPERATURE**I (a) High Gearbox Temperature**

Proceed according to Section 3.2.4 - GEARBOX TEMPERATURE.

NOTE

A cautionary (yellow) gearbox temperature range is not imposed by the engine manufacturer. However, there is a delay between power changes and gearbox temperature. Therefore, a cautionary range has been added to the G1000 (if installed) or MED (if installed) gearbox temperature instrument solely to make the pilot attentive to the gearbox temperature approaching the maximum allowable limit. There is no specific time limit associated with operating in the cautionary gearbox temperature range.

END OF CHECKLIST

4B.2.6 FUEL TEMPERATURE(a) High Fuel Temperature

Proceed according to Section 3.2.5 - L/R FUEL TEMPERATURE.

(b) Low Fuel Temperature

- Increase power.
- Reduce airspeed.

CAUTION

At low ambient temperature conditions and/or at high airspeeds with low power settings, it can be assumed that the above mentioned procedure will increase the temperature(s). If the fuel temperature does not return to the green range perform a precautionary landing on the nearest suitable airfield. Prepare for an engine failure in accordance with Section 3.3.4 - ENGINE FAILURE IN FLIGHT.

END OF CHECKLIST

4B.2.7 VOLTAGE(a) Low Voltage Indication on the Ground with Engine Running

- Terminate flight preparation.

(b) Low Voltage During Flight

1. Circuit breakers check
2. Electrical equipment OFF if not needed

If Low Voltage Condition Still Exists:

- Follow procedure in Section 3.2.8 - ALTERNATOR FAIL.

NOTE

This procedure is applicable if either the voltmeter is out of the green range or VOLTS LOW (if G1000 is installed) or LOW VOLTS (if White Wire annunciator panel is installed) is indicated.

END OF CHECKLIST

4B.2.8 CURRENT

This caution is indicated when the consumption of electric power exceeds 60 A.

1. Electrical equipment switch OFF as necessary and possible to reduce electric load

If the problem does not clear:

2. Land on nearest suitable airfield.

END OF CHECKLIST

4B.3 CAUTION-ALERTS

4B.3.1 ECU A FAILURE

- * Engine ECU A has failed or
- * is being tested during FADEC test procedure before take-off check.

Depending on the type of failure, the ECU failure cautions are either **non latched**, i.e. the caution message disappears after the cause of the caution is no longer present or **latched**, i.e. the caution message remains until cleared through maintenance action. A **non latched** caution clears itself only on the active ECU. **Non latched** caution messages can be cleared on the passive ECU by switching to that ECU with the voter switch.

(a) ECU A Caution on the Ground

1. ALTERNATE AIR check CLOSED
2. Fuel pump OFF
3. VOTER switch check AUTO
4. ECU B caution check OFF
5. VOTER switch ECU A
6. Wait 5 seconds
7. VOTER switch AUTO

If the ECU A caution persists: - terminate flight preparation.

(b) ECU A Caution During Flight

NOTE

In case of a failure in the electronic ECU (Engine Control Unit) A the system automatically switches to ECU B.

1. ALTERNATE AIR OPEN
2. Fuel pump ON
3. Circuit breakers check / reset if necessary
4. VOTER switch AUTO

If the ECU A caution persists: - land at the next suitable airfield. After landing, you may use (a) ECU A Caution on the ground as ECU caution clearing procedure.

NOTE

An ECU FAIL caution is caused by various types of malfunctions. These include internal ECU problems, sensor failure or insufficient performance of air-, fuel- or electrical supply system (e.g. air filter icing).

NOTE

If additional engine problems are observed refer to Section 3.3.3 - ENGINE TROUBLESHOOTING IN FLIGHT.

END OF CHECKLIST

4B.3.2 ECU B FAILURE

- * Engine ECU B has failed or
- * is being tested during FADEC test procedure before take-off check.

Depending on the type of failure, the ECU failure cautions are either non latched, i.e. the caution message disappears after the cause of the caution is no longer present or latched, i.e. the caution message remains until cleared through maintenance action. A non-latched caution clears itself only on the active ECU. Non-latched caution messages can be cleared on the passive ECU by switching to that ECU with the voter switch.

(a) ECU B Caution on the Ground

1. ALTERNATE AIR check CLOSED
2. Fuel pump OFF
3. VOTER switch check AUTO
4. ECU A caution check OFF
5. VOTER switch ECU B
6. Wait 5 seconds
7. VOTER switch AUTO

If the ECU B caution persists: - terminate flight preparation.

(b) ECU B Caution During Flight

NOTE

In case of a failure in the electronic ECU (Engine Control Unit) B, the system automatically switches to ECU A.

CONTINUED

- 1. ALTERNATE AIR OPEN
- 2. Fuel pump ON
- 3. Circuit breakers check / reset if necessary
- 4. VOTER switch AUTO

If the ECU B caution persists: - land at the next suitable airfield. After landing, you may use (a) ECU B Caution on the ground as ECU caution clearing procedure.

NOTE

An ECU FAIL caution is caused by various types of malfunctions. These include internal ECU problems, sensor failure or insufficient performance of air-, fuel- or electrical supply system (e.g. air filter icing).

NOTE

If additional engine problems are observed refer to Section 3.3.3 - ENGINE TROUBLESHOOTING IN FLIGHT.

END OF CHECKLIST

4B.3.3 FUEL QUANTITY LOW

Left fuel quantity is low.

- 1. Fuel transfer pump ON
- 2. Fuel quantity check

CAUTION

As soon as the amount of usable fuel in the main tank is low, a caution message is displayed. The indication is calibrated for straight and level flight. The caution message may be triggered during turns which are flown with slip, or while taxiing in curves.

If FUEL LOW (if G1000 is installed) or LOW FUEL (if White Wire Annunciator Panel is installed) Caution Is Caused By Un-Coordinated Flight:

CAUTION

Prolonged un-coordinated flight can cause fuel starvation to the engine resulting in a loss of power.

- 3. Return to coordinated flight (not more than approx. half a ball sideslip, 3° - 5° bank)

If the Caution Does Not Extinguish:

- Expect loss of fuel.
- 4. Fuel valve EMERGENCY
- 5. Fuel transfer pump OFF

CONTINUED

If the Caution Does Not Extinguish:

- Be prepared for an emergency landing.
- Proceed in accordance with Section 3.7.1 - EMERGENCY LANDING WITH ENGINE OFF.

WARNING

If air enters the high pressure fuel pump (e.g. empty fuel tank), an inspection of the pump is necessary prior to next flight.

END OF CHECKLIST

4B.3.4 COOLANT LEVEL

Engine coolant level is low.

A low coolant caution alert may indicate a loss of coolant. This will subsequently lead to decreased engine cooling capability/loss of engine power due to engine failure.

1. Annunciations / engine instruments. monitor

Refer to Section 4B.2.2 - COOLANT TEMPERATURE.

NOTE

The indication is calibrated for straight and level flight. The caution message may be triggered during turns which are flown with slip, or while taxiing in curves.

END OF CHECKLIST

4B.3.5 PITOT HEATING FAILURE

Pitot heating system has failed.

If in Icing Conditions:

1. Expect loss of airspeed indication.
2. Leave icing zone / refer to Section 3.9.1 - ICING.

END OF CHECKLIST

4B.3.6 ENGINE CAUTION (IF WHITE WIRE ANNUNCIATOR PANEL IS INSTALLED)

Engine limit exceeded.

1. Engine indications check
2. Acknowledge button. press

NOTE

If an indication is near the end of the green range, it may happen that it switches over to the yellow or red range for a short time. This will also cause the ENGINE caution light to illuminate.

NOTE

If an indication is outside of the green range, proceed in accordance with 4B.2 - INSTRUMENT INDICATIONS OUTSIDE OF THE GREEN RANGE.

END OF CHECKLIST

4B.4 CANOPY IN COOLING GAP POSITION**CAUTION**

If take-off was inadvertently done with the canopy in the cooling gap position, do not attempt to close the canopy in flight. Land the airplane and close the canopy on ground.

4B.5 FAILURES IN FLAP OPERATING SYSTEM

4B.5.1 FAILURE IN POSITION INDICATION OR FUNCTION

1. FLAPS position check visually
2. Airspeed. keep in white range (max. 98 KIAS)
3. FLAPS switch. re-check all positions

4B.5.2 MODIFIED APPROACH PROCEDURE DEPENDING ON THE AVAILABLE FLAP SETTING

NOTE

For landing distances with an abnormal flap position refer to 5.3.12 - LANDING DISTANCE - ABNORMAL FLAP POSITION.

(a) Only UP Available:

Airspeed. see table below:

940 kg (2072 lb)	1000 kg (2205 lb)	1100 kg (2425 lb)	1200 kg (2646 lb)	1216 kg (2681 lb)	1280 kg (2822 lb) and above
71 KIAS	73 KIAS	78 KIAS	82 KIAS	82 KIAS	83 KIAS

Land at a flat approach angle, use POWER lever to control airplane speed and rate of descent.

CONTINUED

(b) Only T/O Available:

Airspeed see table below:

940 kg (2072 lb)	1000 kg (2205 lb)	1100 kg (2425 lb)	1200 kg (2646 lb)	1216 kg (2681 lb)	1280 kg (2822 lb) and above
68 KIAS	70 KIAS	74 KIAS	77 KIAS	77 KIAS	78 KIAS

Land at a flat approach angle, use POWER lever to control airplane speed and rate of descent.

(c) Only LDG Available:

Perform normal landing.

END OF CHECKLIST

4B.6 LIGHTNING STRIKE

1. Airspeed. as low as practicable, do not exceed v_o (refer to Section 2.2)
2. Grasp airplane controls firmly
3. Autopilot (if installed) disengage (check)
4. PFD (if G1000 is installed) / verify periodically
backup instruments
5. Continue flight below v_o (refer to Section 2.2)
6. Land on the next suitable airfield

CAUTION

Due to possible damage to the airplane obey the following instructions:

- Avoid abrupt or full control surface movements.
- Avoid high g-loads on the airframe.
- Avoid high yaw angles.
- Avoid turbulent air as far as possible (e.g. lee effects).
- Do not fly into areas of known or forecast icing.

END OF CHECKLIST

4B.7 LANDING WITH MASS ABOVE MAXIMUM LANDING MASS

NOTE

Refer to Section 4A.5.12 - APPROACH AND LANDING for landings with a mass up to 1216 kg (2681 lb), and if MÄM 40-574 is carried out for landings with a mass up to 1280 kg (2822 lb).

Perform landing approach and landing according to Chapter 4A, but maintain an increased airspeed during final landing approach.

Approach speed. 77 KIAS for a mass above 1280 kg
(2822 lb), flaps LDG

END OF CHECKLIST

4B.8 STARTING ENGINE WITH EXTERNAL POWER

4B.8.1 BEFORE STARTING ENGINE

1. Pre-flight inspection complete
2. Rudder pedals adjusted and locked
3. Passengers instructed
4. Safety harnesses all fastened
5. Rear door closed and locked
6. Door lock (if installed). unlocked, key removed
7. Front canopy Position 1 or 2 (“cooling gap”)
8. Canopy lock (if installed) unlocked, key removed

CAUTION

When operating the canopy, pilots / operators are to ensure that there are no obstructions between the canopy and the mating frame, for example seat belts, clothing, etc. When operating the locking handle do NOT apply undue force.

NOTE

A slight downward pressure on the canopy may be required to ease the handle operation.

9. Parking brake set
10. Flight controls. free movement
11. Trim wheel T/O
12. POWER lever. check IDLE

CONTINUED

13. Friction device on POWER lever adjusted
14. Alternate air check CLOSED
15. Alternate static valve check CLOSED
16. VOTER switch check AUTO
17. Fuel pumps check OFF
18. ELECTRIC MASTER check OFF
19. AVIONIC MASTER check OFF
20. External power connect
21. ELECTRIC MASTER ON
22. G1000 (if installed) wait until power-up completed. Press
ENT on MFD to acknowledge

NOTE

If the G1000 avionics system is installed, the engine instruments are only available on the MFD after item 22 has been completed.

23. White Wire annunciator panel (if installed) . . . check and press acknowledge button
24. COOL LVL caution on G1000 (if installed) . . check OFF
or WATERLEV caution on SED (if installed)
25. Fuel temperature check

WARNING

Never rotate the propeller by hand.

END OF CHECKLIST

4B.8.2 STARTING ENGINE

CAUTION

Do not operate the engine starter motor for more than 10 seconds, because of possible overheating of the starter motor.

If the STARTER annunciation on the G1000 (if installed) or START on the White Wire annunciator panel (if installed) comes on after the engine has started and the START KEY has been released, set the ENGINE MASTER to OFF and investigate the problem.

WARNING

If the oil pressure has not moved from the red range within 3 seconds after starting, set the ENGINE MASTER switch to OFF and investigate problem.

NOTE

At low ambient temperatures it is possible that the engine will not start at the first attempt. In this case wait 60 seconds between the start attempts.

- 1. Strobe lights (ACL) ON
- 2. ENGINE MASTER ON

CONTINUED

3. Annunciators / GLOW ON (if G1000 check ON is installed) or GLOW (if White Wire annunciator panel is installed)

NOTE

GLOW ON (if G1000 is installed) or GLOW (if White Wire annunciator panel is installed) is indicated only when the engine is cold.

4. Annunciators / engine indications check

WARNING

Before starting the engine the pilot must ensure that the propeller area is free, and no persons can be endangered.

After the GLOW ON (if G1000 is installed) or GLOW (if White Wire annunciator panel is installed) indication is extinguished:

5. START KEY START as required / release when engine has started.
6. Annunciators / engine indications check OK/normal range
7. Annunciators / STARTER (if G1000 check OFF is installed) or START (if White Wire annunciator panel is installed)
8. Annunciators / Oil pressure check OK
9. Circuit breakers check all IN
10. Idle RPM check, 710 ± 30 RPM (above 7,000 ft pressure altitude idle RPM might be higher)
11. External power. disconnect
12. External power unit. check disconnected and moved clear of the airplane

END OF CHECKLIST

4B.9 ERRONEOUS INDICATIONS OF AIRSPEED OR ALTITUDE

Erroneous indications on the airspeed indicator, altimeter, vertical speed indicator, or erroneous behavior of the autopilot (if equipped) may be the result of a static source blockage.

- 1. Alternate static source OPEN
- 2. Pitot heat ON
- 3. Emergency window(s) CLOSE
- 4. Air vents in cabin CLOSE

END OF CHECKLIST

CHAPTER 5

PERFORMANCE

		Page
	5.1 INTRODUCTION	5-3
	5.2 USE OF THE PERFORMANCE TABLES AND DIAGRAMS	5-3
	5.3 PERFORMANCE TABLES AND DIAGRAMS	5-4
	5.3.1 AIRSPEED CALIBRATION	5-4
	5.3.2 FUEL FLOW	5-5
	5.3.3 PRESSURE ALTITUDE - DENSITY ALTITUDE	5-6
	5.3.4 INTERNATIONAL STANDARD ATMOSPHERE	5-7
	5.3.5 STALLING SPEEDS	5-8
	5.3.6 WIND COMPONENTS	5-10
	5.3.7 TAKE-OFF DISTANCE	5-11
	5.3.8 CLIMB PERFORMANCE - TAKE-OFF CLIMB	5-17
	5.3.9 CLIMB PERFORMANCE - CRUISE CLIMB	5-20
	5.3.10 TIME, FUEL AND DISTANCE TO CLIMB	5-23
	5.3.11 CRUISE PERFORMANCE	5-26
	5.3.12 LANDING DISTANCES	5-28
	5.3.13 LANDING DISTANCE - ABNORMAL FLAP POSITION	5-34
	5.3.14 GO AROUND CLIMB PERFORMANCE	5-38
	5.3.15 GLIDE	5-41
	5.3.16 APPROVED NOISE DATA	5-42

I Intentionally left blank.

5.1 INTRODUCTION

The performance tables and diagrams on the following pages are presented so that, on the one hand, you can see what performance you can expect from your airplane, while on the other they allow comprehensive and sufficiently accurate flight planning. The values in the tables and the diagrams were obtained in the framework of the flight trials using an airplane and power-plant in good condition, and corrected to the conditions of the International Standard Atmosphere (ISA = 15°C / 59°F and 1,013.25 hPa / 29.92 inHg at sea level).

The performance diagrams and tables do not take into account variations in pilot experience or a poorly maintained airplane. The performances given can be attained if the procedures quoted in this manual are applied, and the airplane has been well maintained.

Where appropriate, any flight performance degradation resulting from the absence of wheel fairings is given as a percentage or different value.

5.2 USE OF THE PERFORMANCE TABLES AND DIAGRAMS

In order to illustrate the influence of a number of different variables, the performance data is reproduced in the form of tables or diagrams. These contain sufficiently detailed information so that conservative values can be selected and used for the determination of adequate performance data for the planned flight.

For a conversion of units see Chapter 1.6 - UNITS OF MEASUREMENT.

For temperatures, altitudes and weights between those provided, use a linear interpolation between the neighboring values.

For weights below 1100 kg (2425 lb), use data for the lowest weight.

For operation at outside air temperatures lower than provided in these tables, use data for lowest temperature shown.

Use extreme caution for operation at outside air temperatures higher than provided in the tables (areas are indicated with a diagonal line).

5.3 PERFORMANCE TABLES AND DIAGRAMS

5.3.1 AIRSPEED CALIBRATION

Airspeed Indicator Calibration			
Indicated Airspeed [KIAS]	Calibrated Airspeed [KCAS] at Various Flap Settings		
	UP	T/O	LDG
65	Not applicable	64	64
70	70	69	69
75	75	74	74
80	79	79	78
85	84	84	83
90	89	89	89
95	93	94	94
100	98	99	100
105	103	104	Not applicable
110	108	109	
120	118		
130	128		
140	138		
150	149		
160	159		
170	170		

5.3.2 FUEL FLOW

NOTE

The fuel calculations on the FUEL CALC portion of the G1000 MFD do not use the airplane's fuel quantity indicators. The values shown are numbers which are calculated from the last fuel quantity update done by the pilot and actual fuel flow data. Therefore, the endurance and range data is for information only, and must not be used for flight planning.

Fuel Flow		
Power Setting [%]	Fuel Flow [US gal / h]	Fuel Flow [Liter / h]
30	2.9	11.0
35	3.3	12.5
40	3.7	14.0
45	4.0	15.5
50	4.4	16.5
55	4.7	18.0
60	5.1	19.5
65	5.6	21.5
70	6.1	23.0
75	6.6	25.0
80	7.1	27.0
85	7.6	28.5
90	8.1	30.5
92	8.3	31.5
100	9.4	35.5

5.3.3 PRESSURE ALTITUDE - DENSITY ALTITUDE

Conversion from pressure altitude to density altitude.

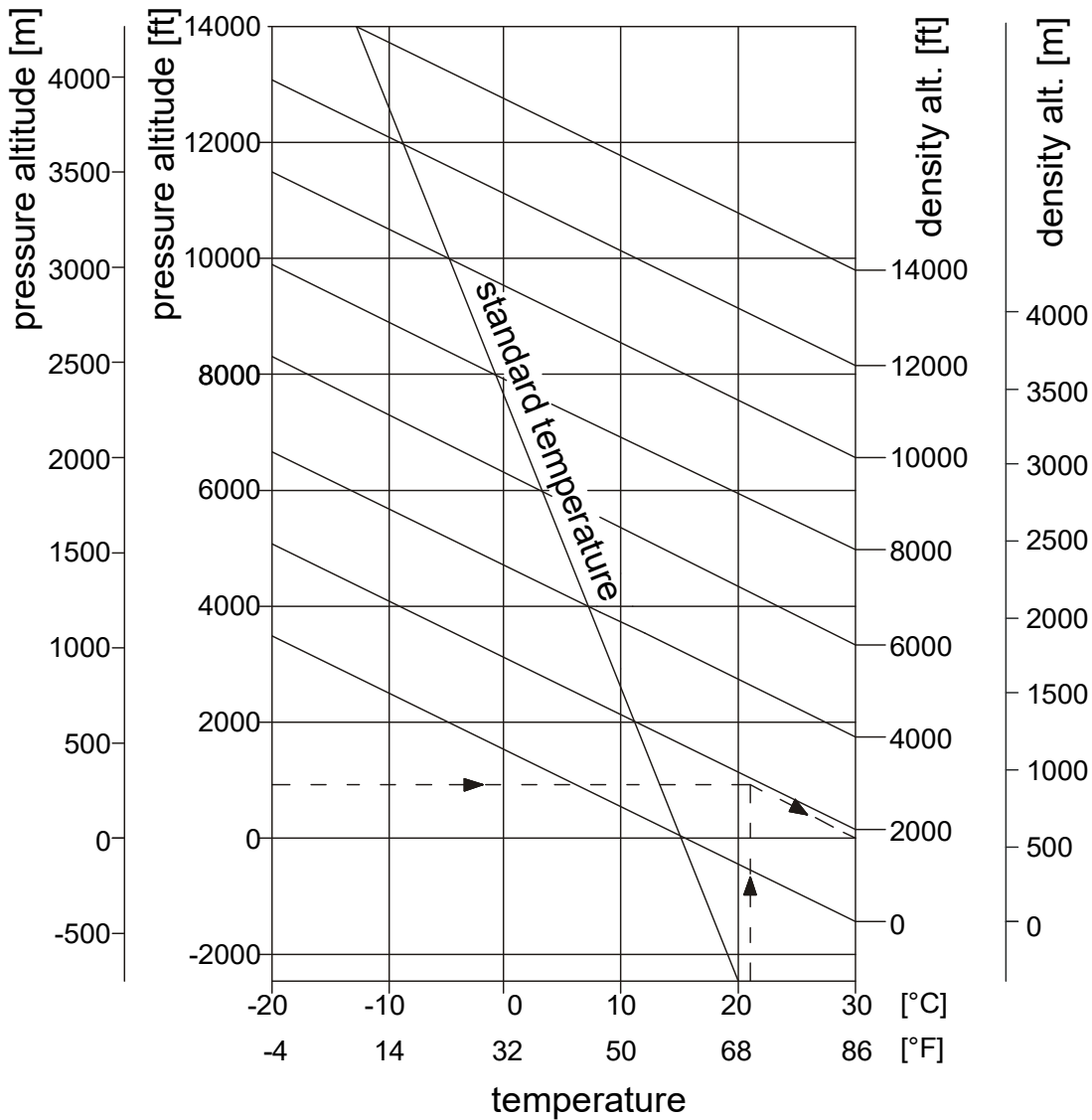

- Example:
1. Set 1,013.25 hPa on altimeter and read pressure altitude (900 ft).
 2. Establish ambient temperature (+21 °C).
 3. Read off density altitude (1800 ft).

Result: From a performance calculation standpoint the airplane is at 1800 ft.

5.3.4 INTERNATIONAL STANDARD ATMOSPHERE

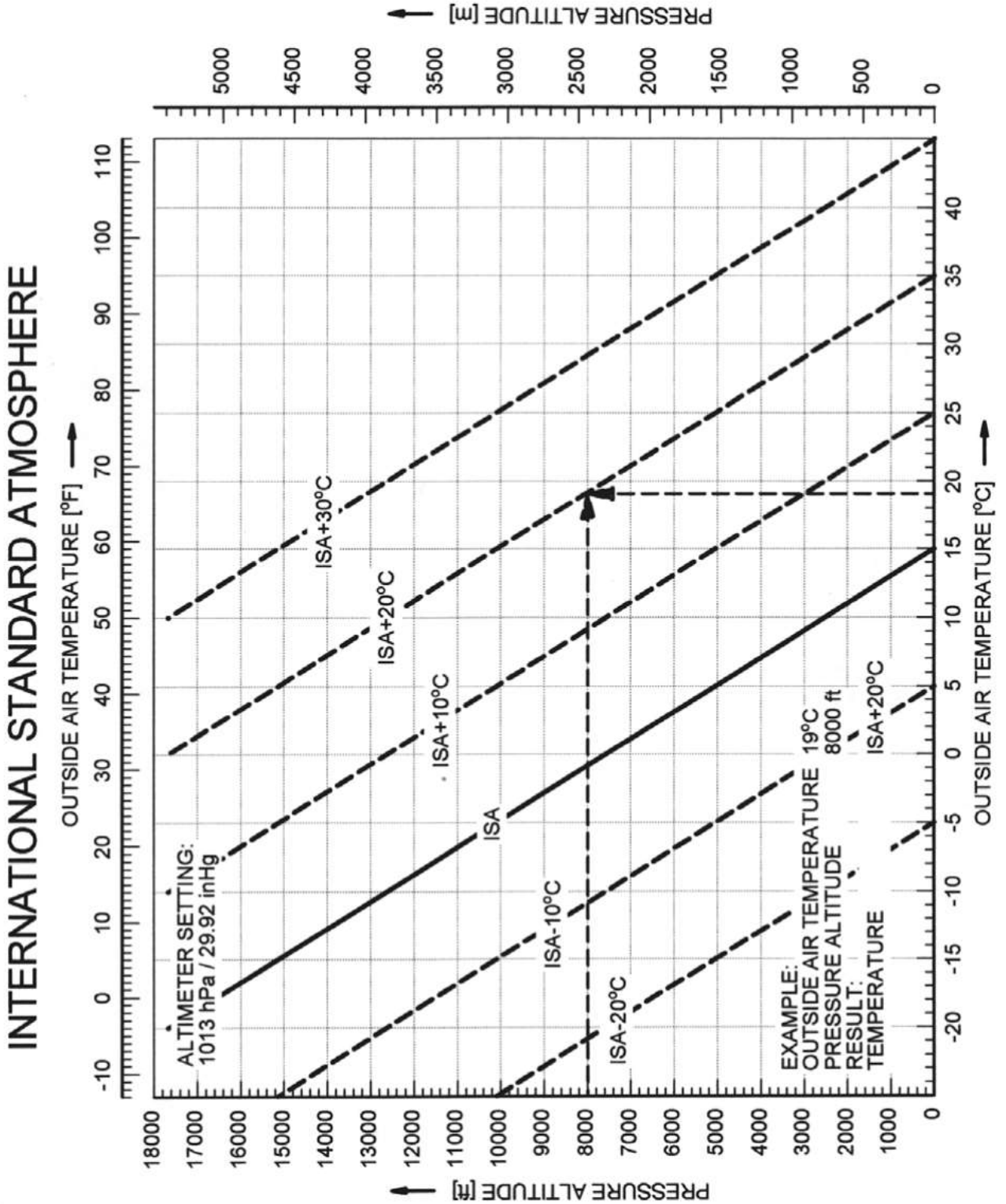

5.3.5 STALLING SPEEDS

(a) Stalling Speeds at Various Flight Masses

Indicated airspeed may not be accurate at stall.

Airspeeds, most forward CG, power off:

1000 kg (2205 lb)	Bank Angle							
	0°		30°		45°		60°	
Flaps	KIAS	KCAS	KIAS	KCAS	KIAS	KCAS	KIAS	KCAS
UP	58	56	59	60	64	66	76	79
T/O	54	53	58	57	63	63	75	74
LDG	55	52	56	55	61	61	72	73

1100 kg (2425 lb)	Bank Angle							
	0°		30°		45°		60°	
Flaps	KIAS	KCAS	KIAS	KCAS	KIAS	KCAS	KIAS	KCAS
UP	61	59	63	64	70	71	83	84
T/O	56	55	60	60	66	66	79	78
LDG	57	54	59	58	65	65	77	77

1200 kg (2646 lb)	Bank Angle							
	0°		30°		45°		60°	
Flaps	KIAS	KCAS	KIAS	KCAS	KIAS	KCAS	KIAS	KCAS
UP	64	61	67	66	73	73	86	87
T/O	60	57	64	62	69	68	82	81
LDG	59	56	62	61	68	67	81	80

1310 kg (2888 lb)	Bank Angle							
	0°		30°		45°		60°	
Flaps	KIAS	KCAS	KIAS	KCAS	KIAS	KCAS	KIAS	KCAS
UP	66	63	68	68	74	75	88	89
T/O	62	59	65	63	71	70	84	83
LDG	60	58	63	62	69	69	82	82

5.3.6 WIND COMPONENTS

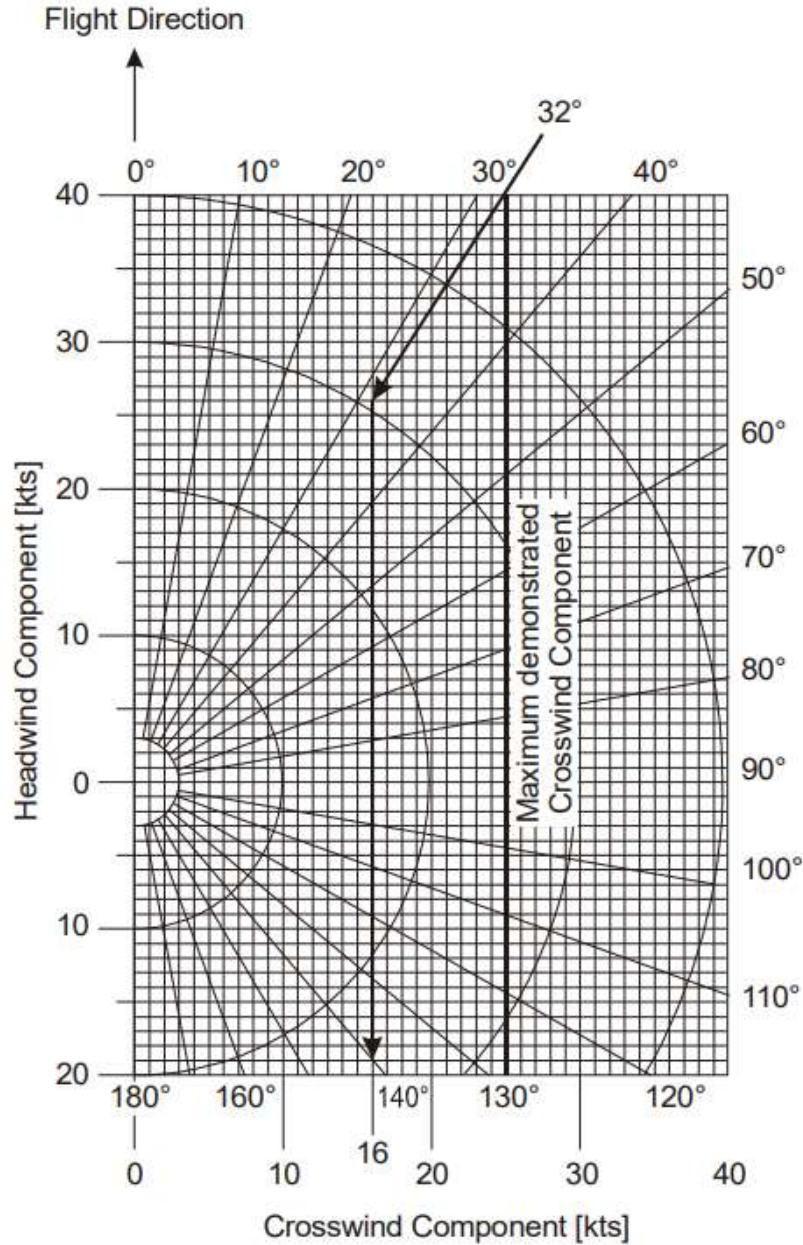

Example: Flight direction : 360°
 Wind : 32°/30 kt
 Result: Crosswind component : 16 kt
 Max. demonstrated crosswind component : 25 kt

5.3.7 TAKE-OFF DISTANCE

Conditions:

- POWER lever MAX
- Flaps T/O
- Runway dry, paved, level
- Nose wheel lift-off @ V_R
- Airspeed for initial climb. @ V_{50}

The following factors are to be applied to the computed take-off distance for the noted condition:

- Headwind: Decrease by 10% for each 12 kt (6.2 m/s) headwind.
- Tailwind: Increase by 10% for each 2 kt (1.0 m/s) tailwind.
- Grass runway
 - dry, 5 cm (2 in) long: Increase the ground roll by 10%.
 - dry, 5 cm (2 in) to 10 cm (3.9 in) long: Increase the ground roll by 30%.
 - dry, 25 cm (9.8 in) long: Increase the ground roll by 45%.
 - longer than 25 cm (9.8 in): A take-off should not be attempted.
 - wet grass: Increase the dry grass runway distance calculations by 20%.
- Soft ground: Increase the ground roll by 50% (in addition to the grass runway distance calculation, if applicable).
- Uphill slope: Increase the ground roll by 15% for each 1% (1 m per 100 m or 1 ft per 100 ft) slope.
- Without wheel fairings: Increase ground roll by 20 m. Increase take - off distance over a 50 ft obstacle by 30 m.

If brakes are not held while applying power, distances apply where full power setting is complete.

WARNING

For a safe take-off the available runway length must be at least equal to the take-off distance over a 50 ft (15 m) obstacle.

WARNING

Poor maintenance condition of the airplane, deviation from the given procedures, uneven runway, as well as unfavorable external factors (rain, unfavorable wind conditions, including cross-wind) will increase the take-off distance.

CAUTION

The factors in the above corrections are typical values. On wet ground or wet soft grass covered runways the take-off roll may become significantly longer than stated. In any case the pilot must allow for the condition of the runway to ensure a safe take-off.

The above corrections for runway slope should be used with caution since published runway slope data is usually the net slope from one end of the runway to the other. Runways may have positions at their length at greater or lesser slopes than published slope, lengthening (or shortening) the take-off roll estimated with these tables.

NOTE

The effect of 50% of the headwind component and 150% of the tailwind component is already incorporated in the head- and tailwind factors.

Take-Off Distance - Normal Procedure - 1310 kg / 2888 lb								
Weight: 1310 kg / 2888 lb			Flaps: T/O					
v _R : 67 KIAS			Power: MAX					
v ₅₀ : 72 KIAS			Runway: dry, paved, level					
Press. Alt. [ft] / [m]	Distance [m]	Outside Air Temperature - [°C] / [°F]						ISA
		0 / 32	10 / 50	20 / 68	30 / 86	40 / 104	50 / 122	
SL	Ground Roll	365	385	410	430	460	495	397
	15 m / 50 ft	550	580	610	640	680	720	590
1000 305	Ground Roll	390	410	435	465	500	535	418
	15 m / 50 ft	580	610	640	680	730	770	616
2000 610	Ground Roll	415	440	465	500	540	575	439
	15 m / 50 ft	610	640	680	730	780	830	646
3000 914	Ground Roll	440	470	500	540	580	625	463
	15 m / 50 ft	650	680	720	780	840	890	677
4000 1219	Ground Roll	470	500	540	590	630	680	490
	15 m / 50 ft	690	720	780	840	900	960	708
5000 1524	Ground Roll	505	535	585	640	685		519
	15 m / 50 ft	730	770	840	910	970		745
6000 1829	Ground Roll	540	585	640	700	750		549
	15 m / 50 ft	770	830	900	980	1040		783
7000 2134	Ground Roll	580	640	700	765	820		585
	15 m / 50 ft	820	900	980	1060	1130		828
8000 2438	Ground Roll	635	700	770	845	900		628
	15 m / 50 ft	890	970	1060	1160	1230		881
9000 2743	Ground Roll	695	770	850	915	990		674
	15 m / 50 ft	970	1060	1160	1250	1330		937
10000 3048	Ground Roll	765	850	910	995			729
	15 m / 50 ft	1050	1160	1240	1340			1000

For the distance in [ft] divide by 0.3048 or multiply by 3.28.

Take-Off Distance - Normal Procedure - 1280 kg / 2822 lb								
Weight: 1280 kg / 2822 lb			Flaps: T/O					
V _R : 67 KIAS			Power: MAX					
V ₅₀ : 72 KIAS			Runway: dry, paved, level					
Press. Alt. [ft] / [m]	Distance [m]	Outside Air Temperature - [°C] / [°F]						ISA
		0 / 32	10 / 50	20 / 68	30 / 86	40 / 104	50 / 122	
SL	Ground Roll	365	385	405	425	460	490	391
	15 m / 50 ft	540	570	600	630	670	710	581
1000 305	Ground Roll	385	410	430	460	495	530	413
	15 m / 50 ft	580	600	630	670	720	760	609
2000 610	Ground Roll	410	435	460	495	535	570	436
	15 m / 50 ft	610	640	670	720	770	820	636
3000 914	Ground Roll	435	465	495	535	580	620	460
	15 m / 50 ft	640	670	710	770	820	880	668
4000 1219	Ground Roll	470	495	535	585	625	675	486
	15 m / 50 ft	680	720	770	830	890	950	701
5000 1524	Ground Roll	500	535	580	635	680	/	513
	15 m / 50 ft	720	760	830	890	950	/	735
6000 1829	Ground Roll	535	580	635	695	740	/	544
	15 m / 50 ft	760	820	890	970	1030	/	772
7000 2134	Ground Roll	575	635	695	760	810	/	581
	15 m / 50 ft	810	890	970	1050	1120	/	820
8000 2438	Ground Roll	630	695	765	840	895	/	623
	15 m / 50 ft	880	960	1050	1150	1220	/	870
9000 2743	Ground Roll	690	765	845	910	980	/	668
	15 m / 50 ft	960	1050	1150	1230	1320	/	927
10000 3048	Ground Roll	765	845	905	985	/	/	723
	15 m / 50 ft	1040	1140	1230	1330	/	/	992

For the distance in [ft] divide by 0.3048 or multiply by 3.28.

Take-Off Distance - Normal Procedure - 1200 kg / 2645 lb								
Weight: 1200 kg / 2645 lb			Flaps: T/O					
V _R : 65 KIAS			Power: MAX					
V ₅₀ : 70 KIAS			Runway: dry, paved, level					
Press. Alt. [ft] / [m]	Distance [m]	Outside Air Temperature - [°C] / [°F]						ISA
		0 / 32	10 / 50	20 / 68	30 / 86	40 / 104	50 / 122	
SL	Ground Roll	325	345	365	385	410	440	352
	15 m / 50 ft	490	520	540	570	610	640	524
1000 305	Ground Roll	345	365	390	415	445	475	371
	15 m / 50 ft	520	550	570	610	650	690	548
2000 610	Ground Roll	365	390	415	445	480	515	391
	15 m / 50 ft	550	580	610	650	700	740	576
3000 914	Ground Roll	390	415	445	485	520	560	413
	15 m / 50 ft	580	610	650	700	750	800	602
4000 1219	Ground Roll	420	445	480	525	565	610	438
	15 m / 50 ft	610	640	700	750	800	860	633
5000 1524	Ground Roll	450	480	525	575	615		462
	15 m / 50 ft	650	690	750	810	870		666
6000 1829	Ground Roll	480	525	575	630	670		491
	15 m / 50 ft	690	740	810	880	940		700
7000 2134	Ground Roll	520	570	630	690	735		524
	15 m / 50 ft	740	800	880	960	1010		741
8000 2438	Ground Roll	570	630	695	760	810		563
	15 m / 50 ft	800	870	960	1040	1110		789
9000 2743	Ground Roll	625	695	765	830	895		606
	15 m / 50 ft	870	950	1050	1120	1200		839
10000 3048	Ground Roll	690	765	825	900			656
	15 m / 50 ft	950	1040	1110	1210			899

For the distance in [ft] divide by 0.3048 or multiply by 3.28.

Take-Off Distance - Normal Procedure - 1100 kg / 2425 lb								
Weight: 1100 kg / 2425 lb			Flaps: T/O					
V _R : 61 KIAS			Power: MAX					
V ₅₀ : 67 KIAS			Runway: dry, paved, level					
Press. Alt. [ft] / [m]	Distance [m]	Outside Air Temperature - [°C] / [°F]						ISA
		0 / 32	10 / 50	20 / 68	30 / 86	40 / 104	50 / 122	
SL	Ground Roll	280	295	310	330	355	380	303
	15 m / 50 ft	430	450	470	490	530	560	457
1000 305	Ground Roll	295	315	335	355	385	410	318
	15 m / 50 ft	450	470	500	530	570	600	478
2000 610	Ground Roll	315	335	355	385	415	445	336
	15 m / 50 ft	480	500	530	570	600	650	498
3000 914	Ground Roll	340	360	385	415	450	480	356
	15 m / 50 ft	500	530	560	610	650	690	523
4000 1219	Ground Roll	360	385	415	455	490	525	377
	15 m / 50 ft	530	560	600	650	700	750	549
5000 1524	Ground Roll	385	415	455	495	530		399
	15 m / 50 ft	560	600	650	710	750		578
6000 1829	Ground Roll	415	455	495	545	580		423
	15 m / 50 ft	600	650	700	770	820		608
7000 2134	Ground Roll	450	495	545	600	640		452
	15 m / 50 ft	640	700	770	830	890		644
8000 2438	Ground Roll	490	545	605	660	705		485
	15 m / 50 ft	690	760	840	910	970		684
9000 2743	Ground Roll	540	600	665	725	780		523
	15 m / 50 ft	760	830	910	980	1050		730
10000 3048	Ground Roll	600	665	715	785			567
	15 m / 50 ft	830	910	970	1060			786

For the distance in [ft] divide by 0.3048 or multiply by 3.28.

5.3.8 CLIMB PERFORMANCE - TAKE-OFF CLIMB

Conditions:

- POWER lever 92% or max. 2100 RPM
- Flaps T/O
- Airspeed 72 KIAS

NOTE

The tables on the following pages show the *rate* of climb. The *gradient* of climb can be calculated using the following:

$$\text{Gradient} [\%] = \frac{\text{ROC} [\text{fpm}]}{\text{TAS} [\text{KTAS}]} \cdot 0.98$$

NOTE

For operation without wheel fairings a climb rate decreased by 20 ft/min must be expected.

NOTE

If MÄM 40-662 is installed, the rate of climb at MTOM (1310 kg / 2888 lb) with a power setting of 100% at MSL and ISA conditions: 714 ft/min (3.6 m/s).

Take - Off Climb - Flaps T/O											
Flaps: T/O						Power: 92% or max.					
V _Y : 72 KIAS						2100 RPM					
Weight [kg] / [lb]	Press. Alt. [ft]	Press. Alt. [m]	Rate of Climb - [ft/min]								
			Outside Air Temperature - [°C] / [°F]								ISA
			-20 -4	-10 14	0 32	10 50	20 68	30 86	40 104	50 122	
1310 / 2888	SL		660	650	640	630	620	615	590	550	629
	2000	610	640	630	620	610	605	595	555	515	613
	4000	1219	620	610	600	595	585	560	520	475	597
	6000	1829	600	590	580	570	555	520	475	/	580
	8000	2438	580	570	555	540	525	480	435	/	557
	10000	3048	555	540	525	510	480	435	/	/	533
	12000	3658	525	510	495	480	435	400	/	/	509
	14000	4267	500	485	475	460	425	360	/	/	492
	16000	4877	490	470	440	385	325	/	/	/	487
	16400	4999	475	450	420	370	305	/	/	/	471
1280 / 2822	SL		675	665	655	645	635	625	600	560	643
	2000	610	655	645	635	625	615	605	570	525	627
	4000	1219	635	625	615	605	595	575	530	485	611
	6000	1829	615	605	595	580	570	535	485	/	593
	8000	2438	595	580	565	550	535	490	445	/	570
	10000	3048	565	550	535	520	490	445	/	/	545
	12000	3658	535	520	505	490	445	410	/	/	520
	14000	4267	510	495	485	470	430	370	/	/	503
	16000	4877	500	480	450	395	330	/	/	/	498
	16400	4999	485	460	430	375	310	/	/	/	482

For the rate of climb in [m/s] divide by 196.8 or multiply by 0.00508.

Take - Off Climb - Flaps T/O											
Flaps: T/O						Power: 92% or max.					
V _Y : 72 KIAS						2100 RPM					
Weight [kg] / [lb]	Press. Alt. [ft]	Press. Alt. [m]	Rate of Climb - [ft/min]								
			Outside Air Temperature - [°C] / [°F]								ISA
			-20 -4	-10 14	0 32	10 50	20 68	30 86	40 104	50 122	
1200 / 2645	SL		740	730	720	710	700	690	665	620	707
	2000	610	720	710	700	690	680	670	630	585	691
	4000	1219	700	690	680	670	660	635	590	540	675
	6000	1829	680	670	660	645	630	595	545		657
	8000	2438	660	645	630	615	600	545	500		633
	10000	3048	630	615	600	585	550	500			607
	12000	3658	595	580	565	550	505	460			581
	14000	4267	575	560	545	530	490	420			564
	16000	4877	560	540	510	450	380				560
	16400	4999	545	520	490	430	360				543
1100 / 2425	SL		835	825	815	800	795	785	755	705	800
	2000	610	815	805	790	780	770	760	715	665	782
	4000	1219	795	780	770	760	750	725	670	615	765
	6000	1829	770	760	750	735	720	680	625		747
	8000	2438	750	735	720	705	685	630	575		722
	10000	3048	720	700	685	670	635	580			695
	12000	3658	685	665	650	635	585	535			667
	14000	4267	660	645	630	615	570	495			649
	16000	4877	650	625	590	530	455				646
	16400	4999	630	605	570	505	430				627

For the rate of climb in [m/s] divide by 196.8 or multiply by 0.00508.

5.3.9 CLIMB PERFORMANCE - CRUISE CLIMB

Conditions:

- POWER lever. 92% or max. 2100 RPM
- Flaps UP
- Airspeed. 88 KIAS

NOTE

The tables on the following pages show the *rate* of climb. The *gradient* of climb cannot easily be determined with a graph, but it can be calculated using the following:

$$\text{Gradient} [\%] = \frac{\text{ROC} [\text{fpm}]}{\text{TAS} [\text{KTAS}]} \cdot 0.98$$

NOTE

For operation without wheel fairings a climb rate decreased by 40 ft/min must be expected.

Cruise Climb - Flaps UP											
Flaps: UP						Power: 92% or max.					
v _Y : 88 KIAS						2100 RPM					
Weight [kg] / [lb]	Press. Alt. [ft]	Press. Alt. [m]	Rate of Climb - [ft/min]								
			Outside Air Temperature - [°C] / [°F]								ISA
			-20 -4	-10 14	0 32	10 50	20 68	30 86	40 104	50 122	
1310 / 2888	SL		665	660	655	650	645	645	620	585	651
	2000	610	655	650	645	640	635	630	595	555	644
	4000	1219	645	640	635	630	620	605	565	525	633
	6000	1829	635	630	620	615	605	580	540	/	621
	8000	2438	620	615	605	600	590	550	505	/	609
	10000	3048	605	600	590	580	555	510	/	/	596
	12000	3658	590	580	570	560	520	480	/	/	581
	14000	4267	575	565	555	540	500	445	/	/	568
	16000	4877	560	550	520	470	405	/	/	/	561
	16400	4999	545	535	500	450	380	/	/	/	546
1280 / 2822	SL		690	685	680	675	670	665	645	605	674
	2000	610	680	675	670	665	660	655	615	575	667
	4000	1219	670	665	660	650	645	630	590	545	656
	6000	1829	660	650	645	635	630	600	560	/	644
	8000	2438	645	635	630	620	610	570	525	/	632
	10000	3048	630	620	615	605	580	535	/	/	619
	12000	3658	615	605	590	580	540	500	/	/	604
	14000	4267	595	585	580	560	525	465	/	/	591
	16000	4877	585	575	545	490	425	/	/	/	583
	16400	4999	570	555	525	470	400	/	/	/	568

For the rate of climb in [m/s] divide by 196.8 or multiply by 0.00508.

Cruise Climb - Flaps UP											
Flaps: UP						Power: 92% or max.					
v_Y: 88 KIAS						2100 RPM					
Weight [kg] / [lb]	Press. Alt. [ft]	Press. Alt. [m]	Rate of Climb - [ft/min]								
			Outside Air Temperature - [°C] / [°F]								ISA
			-20 -4	-10 14	0 32	10 50	20 68	30 86	40 104	50 122	
1200 / 2645	SL		750	750	745	740	735	730	705	665	739
	2000	610	745	740	735	730	725	720	680	635	732
	4000	1219	735	730	725	715	710	690	650	605	721
	6000	1829	725	715	710	700	695	660	620		709
	8000	2438	710	700	695	685	675	630	585		697
	10000	3048	695	685	680	670	640	590			684
	12000	3658	680	665	655	645	600	560			668
	14000	4267	660	650	640	625	585	520			655
	16000	4877	650	640	605	550	480				648
	16400	4999	635	620	585	525	455				632
1100 / 2425	SL		845	840	835	830	825	825	795	750	831
	2000	610	835	830	825	820	815	810	765	715	824
	4000	1219	825	820	815	810	800	785	735	685	814
	6000	1829	815	810	800	795	785	750	700		801
	8000	2438	800	795	785	780	765	715	665		788
	10000	3048	785	775	770	760	730	675			775
	12000	3658	770	760	745	735	685	640			759
	14000	4267	750	740	730	715	665	600			746
	16000	4877	740	730	695	630	555				739
	16400	4999	725	705	675	605	525				722

For the rate of climb in [m/s] divide by 196.8 or multiply by 0.00508.

5.3.10 TIME, FUEL AND DISTANCE TO CLIMB

Conditions:

- POWER lever 92% or max. 2100 RPM
- Flaps UP
- Airspeed 88 KIAS

NOTE

Distances shown are based on zero wind. Fuel for start, taxi and take-off are not included. Add 5% to the time and fuel and 10% to the distance for each 10°C (18°F) increase in OAT.

Example:

OAT at take-off	11°C (52°F)
Airfield pressure altitude	2000 ft (1200 m)
Initial climb weight	1310 kg (2888 lb)
OAT at cruise	-17°C (2°F)
Cruise altitude	16000 ft (4900 m)

Time, fuel and distance to climb at airfield: 3 min, 0.4 US gal and 5 NM (1)

Time, fuel and distance to climb at cruise: 26 min, 3.7 US gal and 43 NM (2)

Subtract (1) from (2) to obtain time, fuel and distance to climb from airfield to cruise:

Time to cruise altitude: 26 min - 3 min = 23 min

Fuel to cruise altitude: 3.7 US gal - 0.4 US gal = 3.3 US gal

Distance to cruise altitude: 43 NM - 5 NM = 38 NM

Time, Fuel and Distance to Climb										
Flaps: UP						Power: 92% or max.				
v _y : 88 KIAS						2100 RPM				
Weight [kg] / [lb]	Press. Alt. [ft]	Press. Alt. [m]	OAT [°C]	OAT [°F]	TAS [kt]	RoC [ft/min]	RoC [m/s]	Time [min]	Fuel [US gal]	Distance [NM]
1310 / 2888	SL		15	59	87	650	3.3	0	0.0	0
	2000	600	11	52	88	645	3.3	3	0.4	5
	4000	1219	7	45	90	645	3.3	6	0.9	9
	6000	1829	3	38	91	640	3.2	9	1.3	14
	8000	2438	-1	30	92	630	3.2	13	1.8	19
	10000	3048	-5	23	94	625	3.2	16	2.2	25
	12000	3658	-9	16	95	620	3.2	19	2.7	31
	14000	4267	-13	9	97	615	3.1	23	3.1	37
	16000	4877	-17	2	98	605	3.1	26	3.7	43
1280 / 2825	SL		15	59	87	675	3.4	0	0.0	0
	2000	600	11	52	88	670	3.4	3	0.4	4
	4000	1219	7	45	90	665	3.4	6	0.8	9
	6000	1829	3	38	91	660	3.4	9	1.3	14
	8000	2438	-1	30	92	655	3.3	12	1.7	19
	10000	3048	-5	23	94	650	3.3	15	2.1	24
	12000	3658	-9	16	95	645	3.3	19	2.6	29
	14000	4267	-13	9	97	635	3.2	22	3.0	36
	16000	4877	-17	2	98	630	3.2	25	3.5	41

Time, Fuel and Distance to Climb										
Flaps: UP						Power: 92% or max.				
v _y : 88 KIAS						2100 RPM				
Weight [kg] / [lb]	Press. Alt.	Press. Alt.	OAT	OAT	TAS	RoC	RoC	Time	Fuel	Distance
	[ft]	[m]	[°C]	[°F]	[kt]	[ft/min]	[m/s]	[min]	[US gal]	[NM]
1200 / 2645	SL		15	59	87	740	3.8	0	0.0	0
	2000	600	11	52	88	735	3.7	3	0.4	4
	4000	1219	7	45	90	730	3.7	5	0.8	8
	6000	1829	3	38	91	725	3.7	8	1.1	13
	8000	2438	-1	30	92	720	3.7	11	1.5	17
	10000	3048	-5	23	94	715	3.6	14	1.9	22
	12000	3658	-9	16	95	710	3.6	17	2.3	27
	14000	4267	-13	9	97	700	3.6	20	2.8	32
	16000	4877	-17	2	98	695	3.5	23	3.2	38
1100 / 2425	SL		15	59	87	830	4.2	0	0.0	0
	2000	600	11	52	88	830	4.2	2	0.3	4
	4000	1219	7	45	90	825	4.2	5	0.7	7
	6000	1829	3	38	91	820	4.2	7	1.0	11
	8000	2438	-1	30	92	810	4.1	10	1.4	15
	10000	3048	-5	23	94	805	4.1	12	1.7	19
	12000	3658	-9	16	95	800	4.1	15	2.1	24
	14000	4267	-13	9	97	795	4.0	18	2.4	28
	16000	4877	-17	2	98	785	4.0	20	2.8	33

5.3.11 CRUISE PERFORMANCE

NOTE

For operation without wheel fairings a performance reduction of 4% TAS at all power settings must be expected.

Conditions:

- █ - Flaps UP
- █ - Weight 1310 kg (2888 lb)

For conversion of OAT to delta-ISA temperatures refer to Chapter 5.3.3 - INTERNATIONAL STANDARD ATMOSPHERE.

Cruise Performance															
Press. Alt. [ft] / [m]	Outside Air Temperature - [°C]														
	ISA-10			ISA			ISA+10			ISA+20			ISA+30		
	Pwr [%]	FF [US gal/h]	TAS [kt]	Pwr [%]	FF [US gal/h]	TAS [kt]	Pwr [%]	FF [US gal/h]	TAS [kt]	Pwr [%]	FF [US gal/h]	TAS [kt]	Pwr [%]	FF [US gal/h]	TAS [kt]
2000 610	92	8.3	134	92	8.3	136	92	8.3	137	92	8.3	138	92	8.3	140
	75	6.6	123	75	6.6	125	75	6.6	126	75	6.6	127	75	6.6	128
	60	5.1	112	60	5.1	113	60	5.1	114	60	5.1	115	60	5.1	116
	45	4.0	95	45	4.0	96	45	4.0	97	45	4.0	97	45	4.0	98
4000 1219	92	8.3	137	92	8.3	138	92	8.3	140	92	8.3	141	92	8.3	142
	75	6.6	126	75	6.6	127	75	6.6	128	75	6.6	129	75	6.6	131
	60	5.1	113	60	5.1	114	60	5.1	116	60	5.1	117	60	5.1	118
	45	4.0	96	45	4.0	97	45	4.0	98	45	4.0	98	45	4.0	99
6000 1829	92	8.3	139	92	8.3	141	92	8.3	142	92	8.3	144	89	8.0	143
	75	6.6	128	75	6.6	129	75	6.6	130	75	6.6	132	75	6.6	133
	60	5.1	115	60	5.1	116	60	5.1	117	60	5.1	118	60	5.1	119
	45	4.0	98	45	4.0	98	45	4.0	99	45	4.0	99	45	4.0	100
8000 2438	92	8.3	142	92	8.3	143	92	8.3	145	92	8.3	146	89	8.0	146
	75	6.6	130	75	6.6	131	75	6.6	133	75	6.6	134	75	6.6	135
	60	5.1	117	60	5.1	118	60	5.1	119	60	5.1	120	60	5.1	121
	45	4.0	99	45	4.0	99	45	4.0	100	45	4.0	100	45	4.0	100
10000 3048	92	8.3	144	92	8.3	146	92	8.3	148	92	8.3	149	90	8.1	149
	75	6.6	132	75	6.6	134	75	6.6	135	75	6.6	136	75	6.6	138
	60	5.1	119	60	5.1	120	60	5.1	121	60	5.1	122	60	5.1	123
	45	4.0	99	45	4.0	100	45	4.0	100	45	4.0	101	45	4.0	101
12000 3658	92	8.3	147	92	8.3	149	92	8.3	150	92	8.3	152	90	8.1	152
	75	6.6	135	75	6.6	136	75	6.6	137	75	6.6	139	75	6.6	140
	60	5.1	121	60	5.1	122	60	5.1	123	60	5.1	124	60	5.1	125
	45	4.0	100	45	4.0	100	45	4.0	101	45	4.0	101	45	4.0	100
14000 4267	92	8.4	150	92	8.4	151	92	8.4	153	85	7.6	149	80	7.1	147
	75	6.6	137	75	6.6	138	75	6.6	140	75	6.6	141	75	6.6	142
	60	5.1	123	60	5.1	124	60	5.1	125	60	5.1	126	60	5.1	127
	45	4.0	101	45	4.0	101	50	4.4	111	50	4.4	111	50	4.4	112
16000 4877	92	8.4	153	92	8.4	154	90	8.2	155	84	7.5	151	79	7.0	149
	75	6.6	139	75	6.6	141	75	6.6	142	75	6.6	144	75	6.6	145
	60	5.1	124	60	5.1	126	60	5.1	127	60	5.1	127	60	5.1	128
	50	4.4	111	50	4.4	111	50	4.4	112	50	4.4	112	50	4.4	112

5.3.12 LANDING DISTANCES

Conditions:

- Power lever IDLE
- Flaps LDG, T/O or UP
- Runway dry, paved, level
- Approach speed V_{REF}

The following factors are to be applied to the computed landing distance for the noted condition:

- Headwind: Decrease by 10% for each 20 kt (10.3 m/s) headwind.
- Tailwind: Increase by 10% for each 3 kt (1.5 m/s) tailwind.
- Paved runway, wet: Increase by 15%.
- Grass runway:
 - dry, 5 cm (2 in) long: Increase the ground roll by 30%.
 - dry, longer than 5 cm (2 in): Increase the ground roll by at least 45%.
 - wet grass or soft runway: Increase the ground roll by 15%.
- Downhill slope: Increase the ground roll by 10% for each 1% (1 m per 100 m or 1 ft per 100 ft) slope.

WARNING

For a safe landing the available runway length must be at least equal to the landing distance over a 50 ft (15 m) obstacle.

WARNING

Poor maintenance condition of the airplane, deviation from the given procedures, uneven runway, as well as unfavorable external factors (rain, unfavorable wind conditions, including cross-wind) will increase the landing distance.

CAUTION

The factors in the above corrections are typical values. On wet ground or wet soft grass covered runways the landing distance may become significantly longer than stated above. In any case the pilot must allow for the condition of the runway to ensure a safe landing.

The above corrections for runway slope should be used with caution since published runway slope data is usually the net slope from one end of the runway to the other. Runways may have positions at their length at greater or lesser slopes than published slope, lengthening (or shortening) the landing roll estimated with these tables.

NOTE

The effect of 50% of the headwind component and 150% of the tailwind component is already incorporated in the head- and tailwind factors.

NOTE

Higher approach speeds result in a significant longer landing distance during flare.

Landing Distance - Flaps LDG - 1310 kg / 2888 lb								
Weight:		1310 kg / 2888 lb			Flaps:		LDG	
V_{REF}:		77 KIAS			Power:		IDLE	
Runway: dry, paved, level								
Press. Alt. [ft] / [m]	Distance [m]	Outside Air Temperature - [°C] / [°F]						ISA
		0 / 32	10 / 50	20 / 68	30 / 86	40 / 104	50 / 122	
SL	Ground Roll	305	315	325	335	355	375	318
	15 m / 50 ft	620	650	670	680	720	760	650
1000 305	Ground Roll	315	325	335	350	370	395	327
	15 m / 50 ft	640	660	680	700	740	790	660
2000 610	Ground Roll	325	335	350	370	390	415	336
	15 m / 50 ft	650	670	690	730	770	810	670
3000 914	Ground Roll	335	350	365	385	410	438	345
	15 m / 50 ft	670	690	710	750	800	840	681
4000 1219	Ground Roll	350	360	380	405	430	455	356
	15 m / 50 ft	680	700	740	780	830	870	692
5000 1524	Ground Roll	360	375	400	425	450	/	366
	15 m / 50 ft	700	720	770	810	860	/	704
6000 1829	Ground Roll	375	395	420	445	475	/	378
	15 m / 50 ft	710	750	790	840	890	/	717
7000 2134	Ground Roll	400	430	460	485	515	/	404
	15 m / 50 ft	750	790	840	890	940	/	746
8000 2438	Ground Roll	455	485	520	550	585	/	452
	15 m / 50 ft	810	870	920	970	1020	/	806
9000 2743	Ground Roll	520	555	585	625	660	/	508
	15 m / 50 ft	890	950	1000	1060	1120	/	875
10000 3048	Ground Roll	580	620	655	695	/	/	565
	15 m / 50 ft	970	1030	1090	1140	/	/	936

For the distance in [ft] divide by 0.3048 or multiply by 3.28.

Landing Distance - Flaps LDG - 1280 kg / 2822 lb								
Weight:		1280 kg / 2822 lb			Flaps:		LDG	
V_{REF}:		77 KIAS			Power:		IDLE	
Runway: dry, paved, level								
Press. Alt. [ft] / [m]	Distance [m]	Outside Air Temperature - [°C] / [°F]						ISA
		0 / 32	10 / 50	20 / 68	30 / 86	40 / 104	50 / 122	
SL	Ground Roll	295	305	320	330	345	365	310
	15 m / 50 ft	610	630	650	670	710	750	639
1000 305	Ground Roll	305	320	330	340	365	385	320
	15 m / 50 ft	630	650	670	690	730	770	647
2000 610	Ground Roll	320	330	340	360	380	405	329
	15 m / 50 ft	640	660	680	720	750	800	657
3000 914	Ground Roll	330	340	355	375	400	425	338
	15 m / 50 ft	650	670	700	740	780	830	667
4000 1219	Ground Roll	340	355	375	395	420	445	348
	15 m / 50 ft	670	690	720	770	810	860	679
5000 1524	Ground Roll	355	370	390	415	440	/	359
	15 m / 50 ft	680	710	750	800	840	/	690
6000 1829	Ground Roll	365	385	415	440	465	/	370
	15 m / 50 ft	700	740	780	830	870	/	702
7000 2134	Ground Roll	395	420	450	475	505	/	396
	15 m / 50 ft	730	780	820	870	920	/	732
8000 2438	Ground Roll	450	480	510	540	570	/	445
	15 m / 50 ft	800	850	900	950	1010	/	792
9000 2743	Ground Roll	510	545	580	615	650	/	501
	15 m / 50 ft	880	930	990	1040	1100	/	861
10000 3048	Ground Roll	575	610	650	685	/	/	557
	15 m / 50 ft	960	1010	1070	1130	/	/	925

For the distance in [ft] divide by 0.3048 or multiply by 3.28.

Landing Distance - Flaps LDG - 1200 kg / 2645 lb								
Weight: 1200 kg / 2645 lb			Flaps: LDG					
V _{REF} : 76 KIAS			Power: IDLE					
Runway: dry, paved, level								
Press. Alt. [ft] / [m]	Distance [m]	Outside Air Temperature - [°C] / [°F]						ISA
		0 / 32	10 / 50	20 / 68	30 / 86	40 / 104	50 / 122	
SL	Ground Roll	280	290	300	310	325	345	293
	15 m / 50 ft	600	620	640	660	690	730	626
1000 305	Ground Roll	290	300	310	320	340	360	301
	15 m / 50 ft	610	630	650	680	720	760	633
2000 610	Ground Roll	300	310	320	340	360	380	310
	15 m / 50 ft	620	640	660	700	740	780	639
3000 914	Ground Roll	310	320	335	355	375	400	319
	15 m / 50 ft	630	650	680	720	760	800	649
4000 1219	Ground Roll	320	335	350	375	395	420	329
	15 m / 50 ft	650	670	700	740	790	830	657
5000 1524	Ground Roll	335	345	370	395	415	/	338
	15 m / 50 ft	660	690	730	770	810	/	668
6000 1829	Ground Roll	345	365	390	415	435	/	348
	15 m / 50 ft	680	710	750	800	840	/	679
7000 2134	Ground Roll	370	400	425	450	475	/	373
	15 m / 50 ft	710	750	790	840	890	/	707
8000 2438	Ground Roll	425	455	485	515	545	/	423
	15 m / 50 ft	780	820	870	920	980	/	768
9000 2743	Ground Roll	490	525	555	590	620	/	482
	15 m / 50 ft	860	910	960	1020	1070	/	839
10000 3048	Ground Roll	560	590	630	665	/	/	540
	15 m / 50 ft	930	990	1050	1100	/	/	905

For the distance in [ft] divide by 0.3048 or multiply by 3.28.

Landing Distance - Flaps LDG - 1100 kg / 2425 lb								
Weight:		1100 kg / 2425 lb			Flaps:		LDG	
V_{REF}:		72 KIAS			Power:		IDLE	
Runway: dry, paved, level								
Press. Alt. [ft] / [m]	Distance [m]	Outside Air Temperature - [°C] / [°F]						ISA
		0 / 32	10 / 50	20 / 68	30 / 86	40 / 104	50 / 122	
SL	Ground Roll	255	265	275	285	300	320	270
	15 m / 50 ft	590	610	630	640	680	720	612
1000 305	Ground Roll	265	275	285	295	315	335	278
	15 m / 50 ft	590	610	630	660	690	730	615
2000 610	Ground Roll	275	285	295	310	330	350	286
	15 m / 50 ft	600	620	640	670	710	750	617
3000 914	Ground Roll	285	295	310	330	345	370	294
	15 m / 50 ft	610	630	650	690	730	770	623
4000 1219	Ground Roll	295	305	325	345	365	385	302
	15 m / 50 ft	620	640	670	710	750	800	630
5000 1524	Ground Roll	305	320	340	360	385	/	311
	15 m / 50 ft	630	650	690	730	780	/	637
6000 1829	Ground Roll	320	335	355	380	405	/	321
	15 m / 50 ft	640	680	720	760	800	/	644
7000 2134	Ground Roll	345	365	390	415	440	/	345
	15 m / 50 ft	670	710	750	800	840	/	671
8000 2438	Ground Roll	400	425	450	480	510	/	394
	15 m / 50 ft	740	790	840	880	930	/	736
9000 2743	Ground Roll	465	495	525	560	590	/	457
	15 m / 50 ft	830	880	930	980	1030	/	810
10000 3048	Ground Roll	535	565	600	635	/	/	518
	15 m / 50 ft	910	960	1010	1070	/	/	880

For the distance in [ft] divide by 0.3048 or multiply by 3.28.

5.3.13 LANDING DISTANCE - ABNORMAL FLAP POSITION

Landing Distance - Abnormal Flap Position - 1310 kg / 2888 lb								
Weight: 1310 kg / 2888 lb			Flaps: T/O or UP					
V _{REF} : 78 KIAS (FLAPS T/O)			Power: IDLE					
83 KIAS (FLAPS UP)			Runway: dry, paved, level					
Press. Alt. [ft] / [m]	Distance [m]	Outside Air Temperature - [°C] / [°F]						ISA
		0 / 32	10 / 50	20 / 68	30 / 86	40 / 104	50 / 122	
SL	Ground Roll	355	365	380	390	415	440	372
	15 m / 50 ft	790	810	840	870	920	970	822
1000 305	Ground Roll	365	380	395	420	445	475	382
	15 m / 50 ft	800	820	860	910	960	1020	827
2000 610	Ground Roll	380	400	425	450	480	510	401
	15 m / 50 ft	810	850	900	950	1010	1060	849
3000 914	Ground Roll	400	430	455	485	515	545	425
	15 m / 50 ft	840	890	940	1000	1060	1120	881
4000 1219	Ground Roll	430	460	490	520	550	580	450
	15 m / 50 ft	880	940	990	1060	1120	1180	917
5000 1524	Ground Roll	460	490	525	555	590	/	476
	15 m / 50 ft	930	990	1050	1110	1170	/	954
6000 1829	Ground Roll	495	525	560	595	630	/	503
	15 m / 50 ft	980	1040	1100	1170	1240	/	992
7000 2134	Ground Roll	545	580	615	655	695	/	547
	15 m / 50 ft	1040	1110	1180	1240	1310	/	1046
8000 2438	Ground Roll	620	660	705	745	790	/	615
	15 m / 50 ft	1150	1220	1290	1370	1440	/	1141
9000 2743	Ground Roll	710	755	800	850	900	/	696
	15 m / 50 ft	1270	1350	1420	1500	1590	/	1243
10000 3048	Ground Roll	800	850	900	955	/	/	776
	15 m / 50 ft	1380	1460	1550	1630	/	/	1340

For the distance in [ft] divide by 0.3048 or multiply by 3.28.

Landing Distance - Abnormal Flap Position - 1280 kg / 2822 lb								
Weight:		1280 kg / 2822 lb			Flaps: T/O or UP			
V_{REF}:		78 KIAS (FLAPS T/O)			Power: IDLE			
		83 KIAS (FLAPS UP)			Runway: dry, paved, level			
Press. Alt. [ft] / [m]	Distance [m]	Outside Air Temperature - [°C] / [°F]						ISA
		0 / 32	10 / 50	20 / 68	30 / 86	40 / 104	50 / 122	
SL	Ground Roll	350	360	370	385	410	430	364
	15 m / 50 ft	770	790	820	850	900	950	803
1000 305	Ground Roll	360	375	390	415	440	465	374
	15 m / 50 ft	780	800	840	890	940	990	808
2000 610	Ground Roll	370	390	415	445	470	500	393
	15 m / 50 ft	790	830	880	930	980	1040	829
3000 914	Ground Roll	395	420	445	475	505	535	416
	15 m / 50 ft	820	870	930	980	1040	1090	863
4000 1219	Ground Roll	420	450	480	510	540	570	441
	15 m / 50 ft	860	920	970	1030	1090	1150	895
5000 1524	Ground Roll	450	480	515	545	580		467
	15 m / 50 ft	910	970	1020	1080	1150		931
6000 1829	Ground Roll	485	515	550	585	620		492
	15 m / 50 ft	960	1020	1080	1140	1210		972
7000 2134	Ground Roll	535	570	605	645	680		537
	15 m / 50 ft	1020	1080	1150	1220	1290		1022
8000 2438	Ground Roll	610	650	690	735	780		606
	15 m / 50 ft	1130	1200	1270	1340	1410		1117
9000 2743	Ground Roll	700	745	790	835	885		685
	15 m / 50 ft	1250	1320	1400	1480	1550		1223
10000 3048	Ground Roll	790	840	890	940			766
	15 m / 50 ft	1360	1440	1520	1610			1319

For the distance in [ft] divide by 0.3048 or multiply by 3.28.

Landing Distance - Abnormal Flap Position - 1200 kg / 2645 lb								
Weight:		1200 kg / 2645 lb			Flaps: T/O or UP			
V_{REF}:		78 KIAS (FLAPS T/O)			Power: IDLE			
		82 KIAS (FLAPS UP)			Runway: dry, paved, level			
Press. Alt. [ft] / [m]	Distance [m]	Outside Air Temperature - [°C] / [°F]						ISA
		0 / 32	10 / 50	20 / 68	30 / 86	40 / 104	50 / 122	
SL	Ground Roll	330	340	350	365	385	410	345
	15 m / 50 ft	760	780	810	840	880	930	790
1000 305	Ground Roll	340	350	370	390	415	440	354
	15 m / 50 ft	760	790	820	870	920	970	790
2000 610	Ground Roll	350	370	395	420	445	470	371
	15 m / 50 ft	770	810	860	910	960	1020	811
3000 914	Ground Roll	375	400	420	450	475	505	394
	15 m / 50 ft	800	850	900	950	1010	1060	837
4000 1219	Ground Roll	400	425	455	480	510	540	416
	15 m / 50 ft	840	890	940	1000	1060	1110	870
5000 1524	Ground Roll	425	455	485	515	545	/	441
	15 m / 50 ft	880	930	990	1050	1110	/	901
6000 1829	Ground Roll	460	490	520	550	585	/	466
	15 m / 50 ft	920	980	1040	1100	1170	/	937
7000 2134	Ground Roll	505	540	575	610	645	/	508
	15 m / 50 ft	980	1040	1110	1170	1240	/	988
8000 2438	Ground Roll	580	620	660	700	740	/	577
	15 m / 50 ft	1090	1160	1230	1300	1370	/	1083
9000 2743	Ground Roll	670	715	760	805	850	/	660
	15 m / 50 ft	1210	1280	1360	1430	1510	/	1187
10000 3048	Ground Roll	765	815	860	910	/	/	740
	15 m / 50 ft	1330	1400	1490	1560	/	/	1289

For the distance in [ft] divide by 0.3048 or multiply by 3.28.

Landing Distance - Abnormal Flap Position - 1100 kg / 2425 lb								
Weight:		1100 kg / 2425 lb			Flaps: T/O or UP			
V_{REF}:		74 KIAS (FLAPS T/O)			Power: IDLE			
		78 KIAS (FLAPS UP)			Runway: dry, paved, level			
Press. Alt. [ft] / [m]	Distance [m]	Outside Air Temperature - [°C] / [°F]						ISA
		0 / 32	10 / 50	20 / 68	30 / 86	40 / 104	50 / 122	
SL	Ground Roll	305	315	325	335	355	380	319
	15 m / 50 ft	750	770	790	820	870	920	777
1000 305	Ground Roll	315	325	340	360	385	405	328
	15 m / 50 ft	750	770	800	850	900	950	780
2000 610	Ground Roll	325	345	365	390	410	435	343
	15 m / 50 ft	760	780	830	880	930	980	783
3000 914	Ground Roll	345	370	390	415	440	465	364
	15 m / 50 ft	760	810	860	920	970	1020	804
4000 1219	Ground Roll	370	395	420	445	470	500	386
	15 m / 50 ft	800	850	900	950	1010	1060	829
5000 1524	Ground Roll	395	420	450	475	505		408
	15 m / 50 ft	840	890	940	1000	1050		857
6000 1829	Ground Roll	425	450	480	510	540		431
	15 m / 50 ft	870	930	990	1040	1100		887
7000 2134	Ground Roll	470	500	535	565	600		471
	15 m / 50 ft	930	990	1050	1110	1170		936
8000 2438	Ground Roll	545	580	620	655	695		542
	15 m / 50 ft	1040	1100	1170	1240	1300		1031
9000 2743	Ground Roll	640	680	720	765	805		627
	15 m / 50 ft	1170	1230	1310	1380	1450		1141
10000 3048	Ground Roll	735	780	825	870			712
	15 m / 50 ft	1280	1360	1430	1510			1242

For the distance in [ft] divide by 0.3048 or multiply by 3.28.

5.3.14 GO-AROUND CLIMB PERFORMANCE

Conditions:

- POWER lever. MAX
- Flaps LDG
- Airspeed. V_{REF}

The climb performance tables show the rate of climb. The gradient and angle of climb can be calculated using the following formula:

$$Gradient [\%] = \frac{ROC [fpm]}{TAS [KTAS]} \cdot 0.98$$

NOTE

The angles of climb at MSL and ISA condition are:

3.0° for Maximum Take-Off Mass / Maximum Landing Mass (1280 kg / 2822 lb)

3.6° for Maximum Landing Mass (1216 kg / 2645 lb)

If MÄM 40-662 is carried out:

2.9° for Maximum Take-Off Mass (1310 kg / 2888 lb)

Go-Around Climb Performance											
Flaps:		LDG								Power: MAX	
V _{REF} :		77 KIAS at 1280 kg (2822 lb) and 1310 kg (2888 lb) 76 KIAS at 1200 kg (2645 lb) 72 KIAS at 1100 kg (2425 lb)									
Weight [kg] / [lb]	Press. Alt. [ft]	Press. Alt. [m]	Rate of Climb - [ft/min]								
			Outside Air Temperature - [°C] / [°F]								ISA
			-20 -4	-10 14	0 32	10 50	20 68	30 86	40 104	50 122	
1310 / 2888	SL		410	405	395	390	385	375	360	335	388
	2000	610	395	390	380	375	370	360	340	310	376
	4000	1219	380	375	365	360	350	340	315	285	364
	6000	1829	365	360	350	345	335	315	285	/	351
	8000	2438	350	345	335	320	310	280	250	/	336
	10000	3048	330	320	310	295	275	240	/	/	315
1280 / 2822	SL		425	415	410	400	395	385	370	345	400
	2000	610	410	400	395	385	380	370	350	320	387
	4000	1219	395	385	380	370	365	350	325	295	375
	6000	1829	380	370	360	355	345	325	295	/	361
	8000	2438	360	355	345	330	320	290	260	/	346
	10000	3048	345	330	320	305	285	250	/	/	326
1200 / 2645	SL		505	500	495	490	480	475	460	425	488
	2000	610	495	490	480	475	465	460	435	400	475
	4000	1219	480	475	465	455	450	435	410	375	462
	6000	1829	465	455	450	440	435	410	380	/	448
	8000	2438	450	440	430	425	410	380	345	/	434
	10000	3048	430	420	410	395	375	335	/	/	418

Go-Around Climb Performance											
Flaps:		LDG								Power: MAX	
V _{REF} :		77 KIAS at 1280 kg (2822 lb) and 1310 kg (2888 lb) 76 KIAS at 1200 kg (2645 lb) 72 KIAS at 1100 kg (2425 lb)									
Weight [kg] / [lb]	Press. Alt. [ft]	Press. Alt. [m]	Rate of Climb - [ft/min]								
			Outside Air Temperature - [°C] / [°F]								ISA
			-20 -4	-10 14	0 32	10 50	20 68	30 86	40 104	50 122	
1100 / 2425	SL		615	615	610	605	605	595	575	535	607
	2000	610	610	605	605	595	585	580	550	510	596
	4000	1219	605	595	585	580	570	555	520	480	582
	6000	1829	585	575	570	560	550	525	490		568
	8000	2438	570	560	550	540	530	495	455		553
	10000	3048	550	540	530	520	495	450			537

5.3.15 GLIDE

The following table shows the glide ratio and the resulting maximum horizontal distance in nautical miles per 1000 ft (305 m) of altitude loss in a glide traveled in still air.

	Glide ratio	Maximum horizontal distance per 1000 ft (305 m) altitude loss
Windmilling propeller	1 : 9.7	1.59 NM (2.94 km)

Conditions:

- Flaps UP
- Airspeed 88 KIAS

CAUTION

The propeller will keep windmilling under all expected conditions. Do not attempt to stop the propeller intentionally.

NOTE

In case of stationary propeller the given numbers are conservative.

NOTE

For operation without wheel fairings the glide ratio is reduced to 9.4; i.e., for every 1000 ft (305 m) of altitude loss the maximum horizontal distance traveled in still air is 1.54 NM (2.85 km). During this the propeller will continue to windmill.

5.3.16 APPROVED NOISE DATA

- █ (a) Maximum Flight Mass 1280 kg (2825 lb):

ICAO Annex 16 Chapter X 74.5 dB(A)

- █ (b) If the Exhaust Pipe with Muffler (MÄM 40-434 or OÄM 40-310) is Installed:

ICAO Annex 16, Chapter X 71.5 dB(A)

- █ (c) Maximum Flight Mass 1310 kg (2888 lb):

ICAO Annex 16 Chapter X 71.4 dB(A)

CHAPTER 6

MASS AND BALANCE / EQUIPMENT LIST

	Page
6.1 INTRODUCTION	6-3
6.2 DATUM PLANE	6-4
6.3 MASS AND BALANCE REPORT	6-4
6.4 FLIGHT MASS AND CENTER OF GRAVITY	6-6
6.4.1 MOMENT ARMS	6-8
6.4.2 LOADING DIAGRAM	6-9
6.4.3 CALCULATION OF LOADING CONDITION	6-10
6.4.4 PERMISSIBLE CENTER OF GRAVITY RANGE	6-14
6.4.5 PERMISSIBLE MOMENT RANGE	6-15
6.5 EQUIPMENT LIST AND EQUIPMENT INVENTORY	6-16

I

Intentionally left blank.

6.1 INTRODUCTION

In order to achieve the performance and flight characteristics described in this Airplane Flight Manual and for safe flight operation, the airplane must be operated within the permissible mass and balance envelope.

The pilot is responsible for adhering to the permissible values for loading and center of gravity (CG). In this, they should note the movement of the CG due to fuel consumption. The permissible CG range during flight is given in Chapter 2.

The procedure for determining the flight mass CG position is described in this Chapter. Over and above this there is a comprehensive list of the equipment approved for this airplane (Equipment List), and also a list of the equipment installed when the airplane was weighed (Equipment Inventory).

Before the airplane is delivered the empty mass and the corresponding CG position are determined, and entered in Section 6.3 - MASS AND BALANCE REPORT.

NOTE

Following equipment changes the new empty mass and the corresponding CG position must be determined by calculation or by weighing.

Following repairs or repainting the new empty mass and the corresponding CG position must be determined by weighing.

Empty mass, empty mass CG position, and the empty mass moment must be certified in the Mass and Balance Report by an authorized person.

NOTE

Refer to Section 1.6 - UNITS OF MEASUREMENT for conversion of SI units to US units and vice versa.

6.2 DATUM PLANE

The Datum Plane (DP) is a plane which is normal to the airplane's longitudinal axis and in front of the airplane as seen from the direction of flight. The airplane's longitudinal axis is parallel with the upper surface of a 600:31 wedge which is placed on top of the rear fuselage in front of the vertical stabilizer. When the upper surface of the wedge is aligned horizontally, the Datum Plane is vertical. The Datum Plane is located 2.194 meter (86.38 in) forward of the most forward point of the root rib on the stub wing.

6.3 MASS AND BALANCE REPORT

The empty mass and the corresponding CG position established before delivery are the first entries in the Mass and Balance Report. Every change in permanently installed equipment, and every repair to the airplane which affects the empty mass or the empty mass CG must be recorded in the Mass and Balance Report.

For the calculation of flight mass and corresponding CG position (or moment), the *current* empty mass and the corresponding CG position (or moment) in accordance with the Mass and Balance Report must always be used.

Condition of the airplane for establishing the empty mass:

- Equipment as per Equipment Inventory (see Section 6.5).
- Including brake fluid, lubricant (1.0 liter / 1.06 qts), coolant, gearbox oil, engine oil (7.0 liter / 7.4 qts), plus unusable fuel (2.0 US gal / approx. 7.6 liter).

6.4 FLIGHT MASS AND CENTER OF GRAVITY

The following information enables you to operate your DA 40 NG within the permissible mass and balance limits. For the calculation of the flight mass and the corresponding CG position the following tables and diagrams are required:

- 6.4.1 - MOMENT ARMS
- 6.4.2 - LOADING DIAGRAM
- 6.4.3 - CALCULATION OF LOADING CONDITION
- 6.4.4 - PERMISSIBLE CENTER OF GRAVITY RANGE
- 6.4.5 - PERMISSIBLE MOMENT RANGE

The diagrams should be used as follows:

1. Take the empty mass and the empty mass moment of your airplane from the Mass and Balance Report, and enter the figures in the appropriate boxes under the column marked Your DA 40 NG in Table 6.4.3 - CALCULATION OF LOADING CONDITION.
2. Read the fuel quantity indicators to determine the fuel quantity. If an indicator shows 14 US gal, up to 19.5 US gal can be in the Long Range Tank. In this case, the exact quantity must be determined with the alternate means for fuel quantity indication.
3. Multiply the individual masses by the moment arms quoted to obtain the moment for every item of loading and enter these moments in the appropriate boxes in Table 6.4.3 - CALCULATION OF LOADING CONDITION.
4. Add up the masses and moments in the respective columns. The total moments may be rounded to whole numbers. The CG position is calculated by dividing the total moment by the total mass (using row 9 for the condition with empty fuel tanks, and row 11 for the pre take-off condition). The resulting CG position must be inside the limits.

As an illustration the total mass and the CG position are entered on Diagram 6.4.4 - PERMISSIBLE CENTER OF GRAVITY RANGE. This checks graphically that the current configuration of the airplane is within the permissible range.

5. Graphical method:

Diagram 6.4.2 - LOADING DIAGRAM is used to determine the moments. The masses and moments for the individual items of loading are added. Then Diagram 6.4.5 - PERMISSIBLE MOMENT RANGE is used to check whether the total moment associated with the total mass is in the admissible range.

█ The result found with the graphical method is less precise. In doubtful cases the result must be verified using the exact method given above.

6.4.1 MOMENT ARMS

The most important lever arms aft of the Datum Plane:

- Front seats : 2.30 m 90.6 in
- Rear seats : 3.25 m 128.0 in
- Wing tank (Standard & Long Range) : 2.63 m 103.5 in
- Baggage in standard compartment : 3.65 m 143.7 in
 - Baggage in baggage tube : 4.32 m 170.1 in
 - Baggage in short baggage extension : 3.97 m 156.3 in
(if OÄM 40-331 is installed)
 - Baggage in baggage extension (if OÄM 40-164 is installed):
 - Forward part : 3.89 m 153.1 in
 - Aft part : 4.54 m 178.7 in

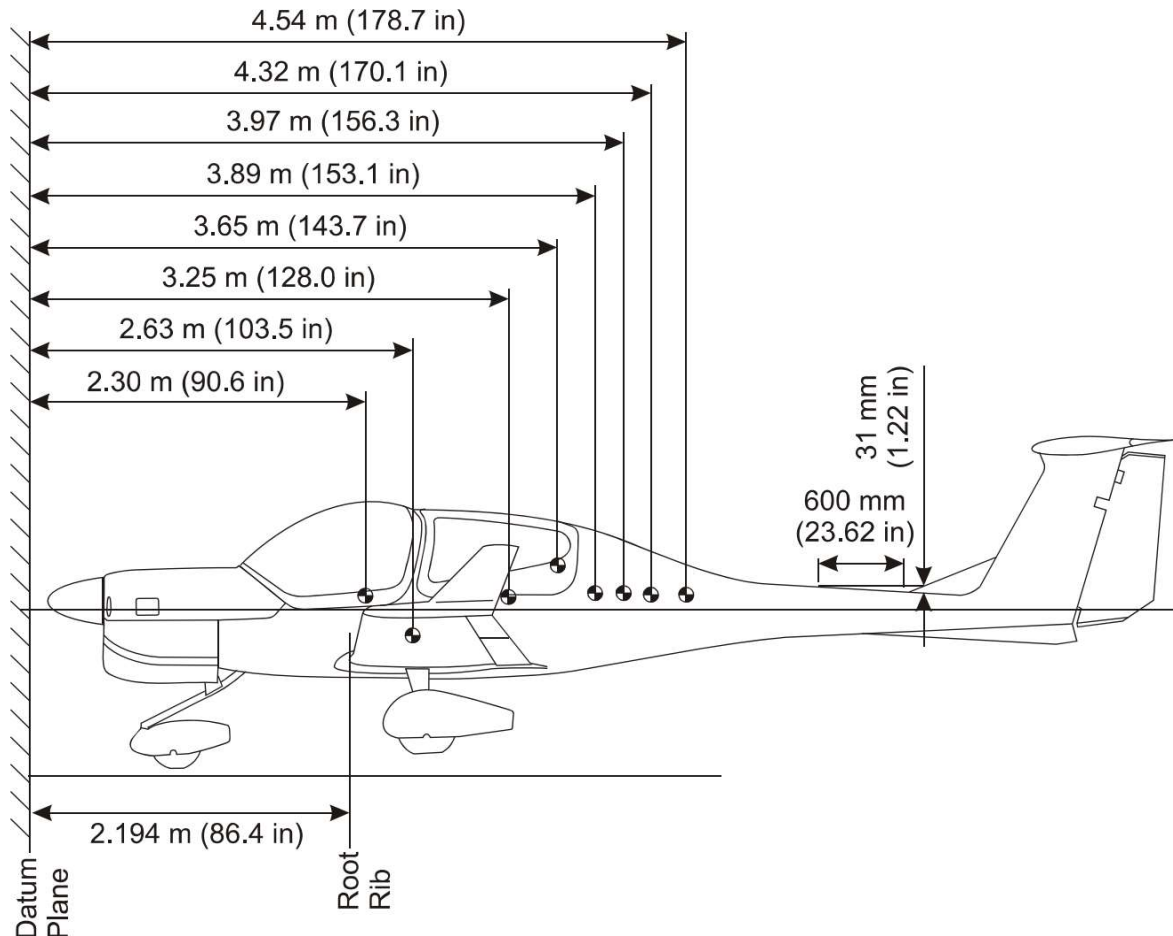

6.4.2 LOADING DIAGRAM

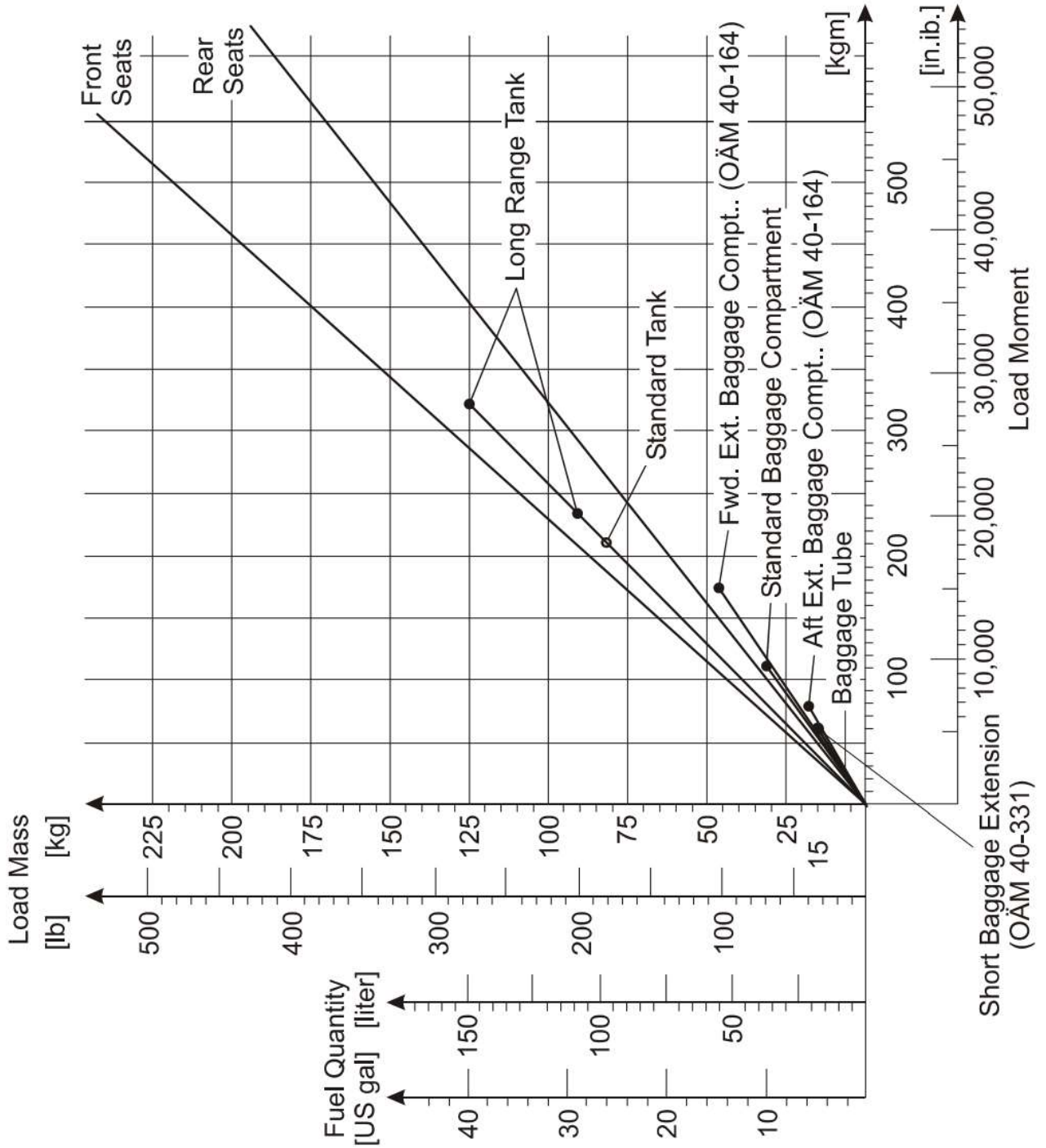

6.4.3 CALCULATION OF LOADING CONDITION

I (a) Standard Tank Configuration

CALCULATION OF LOADING CONDITION	DA 40 NG (Example)		Your DA 40 NG	
	Mass [kg] [lb]	Moment [kgm] [in.lb]	Mass [kg] [lb]	Moment [kgm] [in.lb]
1. Empty mass (from Mass and Balance Report)	900 1,984	2,180.8 189,253		
2. Front seats Lever arm: 2.30 m (90.6 in)	150 331	345.0 29,989		
3. Rear seats Lever arm: 3.25 m (128.0 in)	0 0	0 0		
4. Standard baggage comp. Lever arm: 3.65 m (143.7 in)	20 44	73.0 6,323		
5. Baggage tube Lever arm: 4.32 m (170.1 in)	0 0	0 0		
6. Short baggage extension (OÄM 40-331 carried out) Lever arm: 3.97 m (156.3 in)	0 0	0 0		
7. Forward extended baggage compartment (OÄM 40-164 carried out) Lever arm: 3.89 m (153.1 in)	0 0	0 0		
8. Aft extended baggage compartment (OÄM 40-164 carried out) Lever arm: 4.54 m (178.7 in)	0 0	0 0		

CALCULATION OF LOADING CONDITION	DA 40 NG (Example)		Your DA 40 NG	
	Mass [kg] [lb]	Moment [kgm] [in.lb]	Mass [kg] [lb]	Moment [kgm] [in.lb]
9. Total mass and total moment with empty fuel tanks (Total of 1.-8.)	1,070 2,359	2,598.8 225,565		
10. On-board usable fuel (0.84 kg/liter) (7.01 lb/US gal) Lever arm: 2.63 m (103.5 in)	89 196	234.1 20,286		
11. Total mass and total moment with full fuel tanks (Total 9. plus 10.)	1,159 2,555	2,832.9 245,851		
<p>12. The total moments from rows 9 and 11 (2,598.8 and 2,832.9 kgm) (225,565 and 245,851 in.lb) must be divided by the related total mass (1,070 and 1,159 kg respectively) (2,359 and 2,555 lb) and then located in Diagram 6.4.4 - PERMISSIBLE CENTER OF GRAVITY RANGE.</p> <p>As in our example CG positions (2.429 m and 2.444 m respectively) (95.62 and 96.22 in) and masses fall into the permitted area, this loading condition is allowable.</p>				

(b) Long Range Tank Configuration

CALCULATION OF LOADING CONDITION		DA 40 NG (Example)		Your DA 40 NG	
		Mass [kg] [lb]	Moment [kgm] [in.lb]	Mass [kg] [lb]	Moment [kgm] [in.lb]
1.	Empty mass (from Mass and Balance Report)	900 1,984	2,180.8 189,253		
2.	Front seats Lever arm: 2.30 m (90.6 in)	150 331	345.0 29,989		
3.	Rear seats Lever arm: 3.25 m (128.0 in)	0 0	0 0		
4.	Standard baggage comp. Lever arm: 3.65 m (143.7 in)	20 44	73.0 6,323		
5.	Baggage tube Lever arm: 4.32 m (170.1 in)	0 0	0 0		
6.	Short baggage extension (OÄM 40-331 carried out) Lever arm: 3.97 m (156.3 in)	0 0	0 0		
7.	Forward extended baggage compartment (OÄM 40-164 carried out) Lever arm: 3.89 m (153.1 in)	0 0	0 0		
8.	Aft extended baggage compartment (OÄM 40-164 carried out) Lever arm: 4.54 m (178.7 in)	0 0	0 0		

CALCULATION OF LOADING CONDITION		DA 40 NG (Example)		Your DA 40 NG	
		Mass [kg] [lb]	Moment [kgm] [in.lb]	Mass [kg] [lb]	Moment [kgm] [in.lb]
9.	Total mass and total moment with empty fuel tanks (Total of 1.-8.)	1,070 2,359	2,598.8 225,565		
10.	On-board usable fuel (0.84 kg/liter) (7.01 lb/US gal) Lever arm: 2.63 m (103.5 in)	124 273	326.1 28,256		
11.	Total mass and total moment with full fuel tanks (Total 9. plus 10.)	1,194 2,632	2,924.9 253,821		
12.	<p>The total moments from rows 9 and 11 (2,598.8 and 2,924.9 kgm) (225,565 and 253,821 in.lb) must be divided by the related total mass (1,070 and 1,194 kg respectively) (2,359 and 2,632 lb) and then located in Diagram 6.4.4 - PERMISSIBLE CENTER OF GRAVITY RANGE.</p> <p>As in our example CG positions (2.429 m and 2.450 m respectively) (95.62 and 96.44 in) and masses fall into the permitted area, this loading condition is allowable.</p>				

6.4.4 PERMISSIBLE CENTER OF GRAVITY RANGE

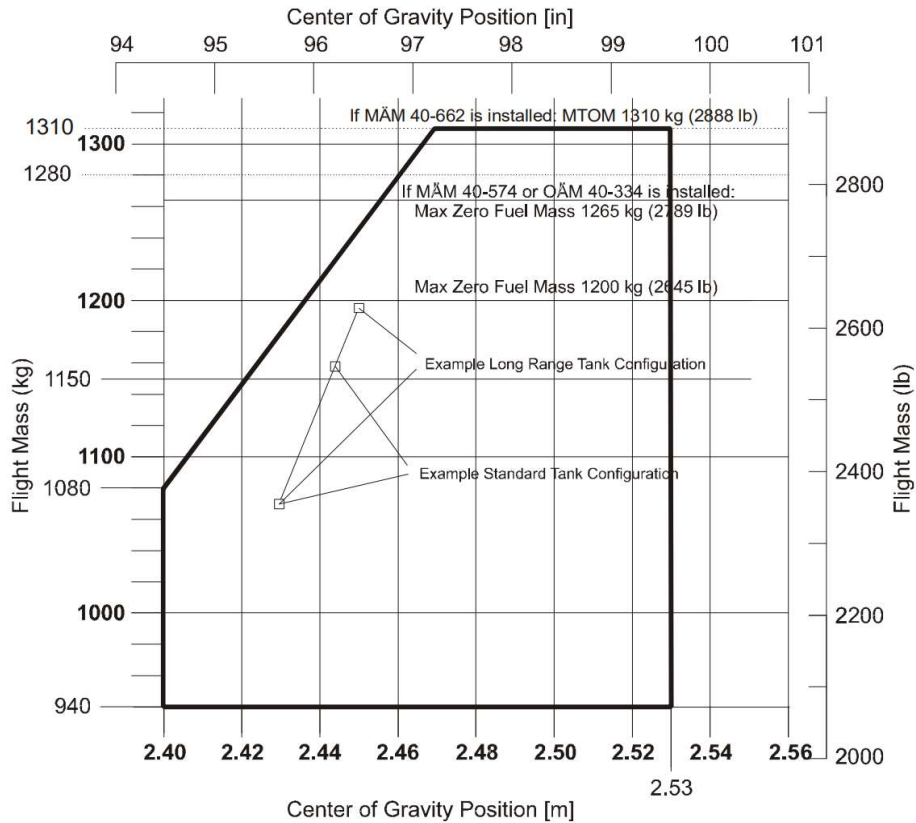

The CGs shown in the diagram are from the example in Tables 6.4.3 - CALCULATION OF LOADING CONDITION (a) and (b), rows 9 and 11.

The flight CG position must be within the following limits:

Most forward CG:

2.40 m (94.5 in) aft of DP from 940 kg to 1080 kg (2072 lb to 2381 lb)

2.46 m (96.9 in) aft of DP at 1280 kg (2822 lb)

If MÄM 40-662 is installed:

2.469 m (97.2 in) aft of DP at 1310 kg (2888 lb)

linear variation between these values

Most rearward CG:

2.53 m (99.6 in) aft of DP from 940 kg (2072 lb) to 1310 kg (2888 lb)

6.4.5 PERMISSIBLE MOMENT RANGE

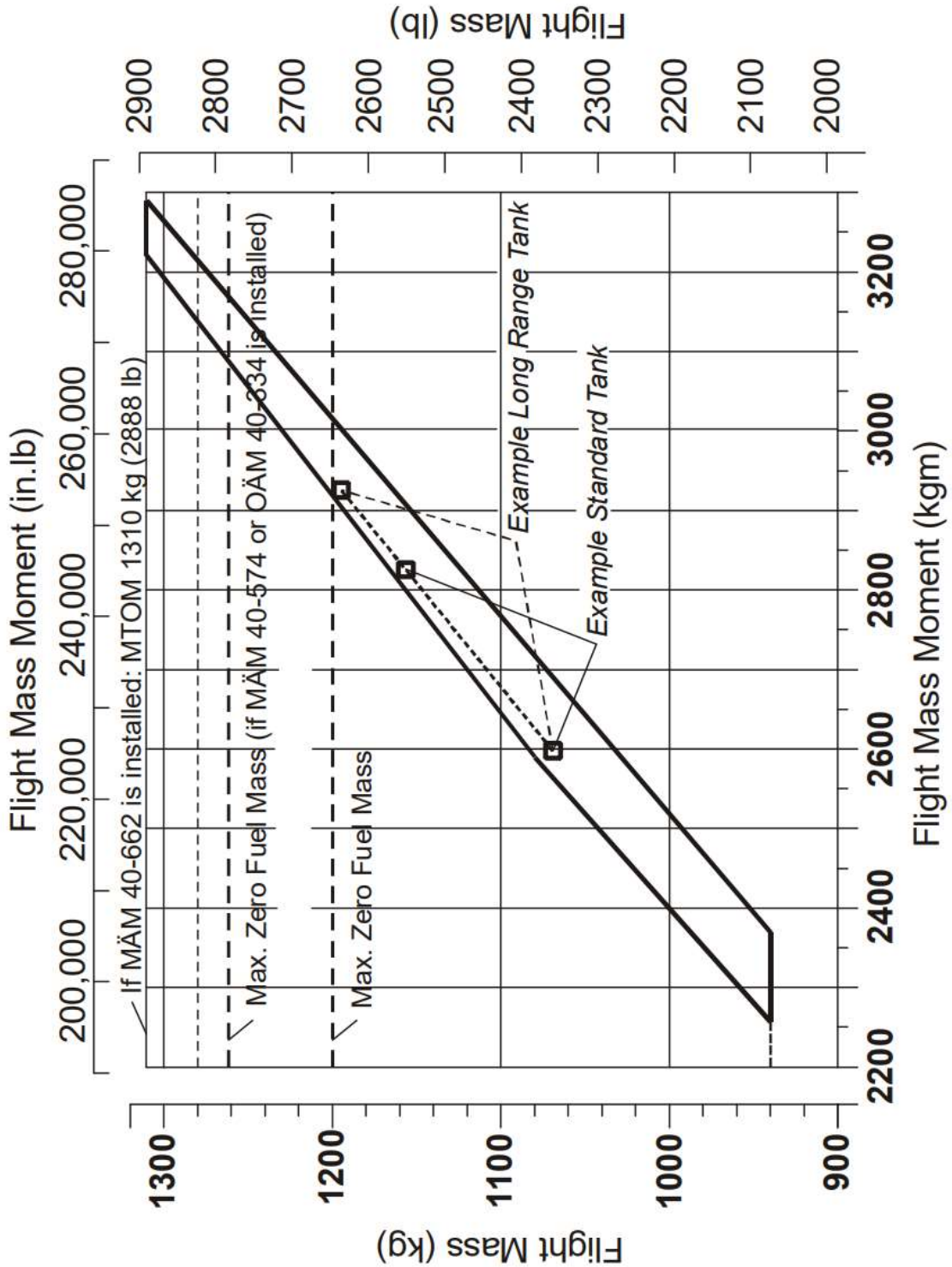

6.5 EQUIPMENT LIST AND EQUIPMENT INVENTORY

All equipment approved for installation in the DA 40 NG is shown in the *Equipment List* below.

The items of equipment installed in your particular airplane are indicated in the appropriate column. The set of items marked as installed constitutes the *Equipment Inventory*.

NOTE

The equipment listed below cannot be installed in any arbitrary combination. The airplane manufacturer must be contacted before removing or installing equipment, with the exception of replacing a unit by an identical unit.

Description	Type	Part No.	Manufacturer	Installed	Mass		Lever Arm	
					lb	kg	in	m
AVIONICS COOLING								
Avionics cooling fan	SAFE 328	305 467-00	Sandia Aerospace					
Avionics cooling fan	Cyclone 21-3	CRB-122253	Lone Star Aviation					
PFD cooling fan	SAFE 128	305 468-00	Sandia Aerospace					
MFD cooling fan	SAFE 128	305 468-00	Sandia Aerospace					
AUTOPILOT SYSTEM								
Pitch servo	GSA 81	011-00878-00	Garmin					
Pitch servo	GSA 81	011-00878-20	Garmin					
Pitch servo mount	GSM 85	011-00894-07	Garmin					
Pitch servo mount	GSM 86	011-01904-03	Garmin					
Pitch clutch cartridge		011-02147-15	Garmin					
Roll servo	GSA 81	011-00878-00	Garmin					
Roll servo	GSA 81	011-00878-20	Garmin					
Roll servo mount	GSM 85	011-00894-07	Garmin					
Roll servo mount	GSM 86	011-01904-03	Garmin					
Roll clutch cartridge		011-02147-08	Garmin					
Pitch trim servo	GSA 81	011-00878-00	Garmin					
Pitch trim servo	GSA 81	011-00878-20	Garmin					
Pitch trim servo mount	GSM 85	011-00894-04	Garmin					
Pitch trim servo mount	GSM 85	011-00894-04	Garmin					

Description	Type	Part No.	Manufacturer	Installed	Mass		Lever Arm	
					lb	kg	in	m
Pitch trim clutch cartridge		011-02147-15	Garmin					
Control stick		DA4-2213-12-90	Diamond Aircraft					
CWS switch		031-00514-0000	Bendix/King					
AP Disc switch		031-00428-0000	Bendix/King					
Trim switch assy		200-09187-0000	Bendix/King					
ELECTRICAL POWER								
Main battery	RG24-15		Concorde					
Emergency battery		D60-2560-91-00	Diamond Aircraft					
ECU backup battery (2 pcs.)	LC-R127R2P		Panasonic					
External power connector		DA4-2443-10-00	Diamond Aircraft					
Additional alternator		ES-10024B-2	Kelly Aerospace					
Alternator pulley		D44-2416-00-34X03	Diamond Aircraft					
Alternator pulley		D44-2416-00-70_1	Diamond Aircraft					
Gear box fan assy		D44-2416-20-00	Diamond Aircraft					
Prop. flange pulley support		D44-2416-00-52_1	Diamond Aircraft					
Additional alternator V-belt		ISO 4184 XPZ L862	Diamond Aircraft					
Additional alternator V-belt		ISO 4184 XPZ L987	Diamond Aircraft					
Additional alternator regulator		VR2000-28-1	Electrosystems Inc.					

Description	Type	Part No.	Manufacturer	Installed	Mass		Lever Arm	
					lb	kg	in	m
CABIN COOLING SYSTEM								
Cabin cooling central unit		D44-2151-00-00	Diamond Aircraft					
Cabin cooling central unit		D44-2153-00-00	Diamond Aircraft					
EQUIPMENT								
Safety belt, pilot	5-01-() Series	5-01-1C0710	Schroth		2.110	0.960	92.520	2.350
Safety belt, co-pilot	5-01-() Series	5-01-1C5710	Schroth		2.110	0.960	92.520	2.350
Safety belt, LH pax	5-01-() Series	5-01-1B5710	Schroth		2.250	1.020	126.800	3.220
Safety belt, RH pax	5-01-() Series	5-01-1B0710	Schroth		2.250	1.020	126.800	3.220
Safety belt, pilot	5-01-() Series	5-01-2G0710	Schroth		2.110	0.960	92.520	2.350
Safety belt, co-pilot	5-01-() Series	5-01-2G5710	Schroth		2.110	0.960	92.520	2.350
Safety belt, LH pax	5-01-() Series	5-01-2H5710	Schroth		2.250	1.020	126.800	3.220
Safety belt, RH pax	5-01-() Series	5-01-2H0710	Schroth		2.250	1.020	126.800	3.220
Safety belt, pilot	5-01-() Series	5-01-2G0701	Schroth		2.110	0.960	92.520	2.350
Safety belt, co-pilot	5-01-() Series	5-01-2G5701	Schroth		2.110	0.960	92.520	2.350
Safety belt, LH pax	5-01-() Series	5-01-2H5701	Schroth		2.250	1.020	126.800	3.220
Safety belt, RH pax	5-01-() Series	5-01-2H0701	Schroth		2.250	1.020	126.800	3.220
Safety belt, pilot	5-01-() Series	5-01-1C0701	Schroth		2.110	0.960	92.520	2.350
Safety belt, co-pilot	5-01-() Series	5-01-1C5701	Schroth		2.110	0.960	92.520	2.350
Safety belt, LH pax	5-01-() Series	5-01-1B5701	Schroth		2.250	1.020	126.800	3.220
Safety belt, RH pax	5-01-() Series	5-01-1B5701	Schroth		2.250	1.020	126.800	3.220

Description	Type	Part No.	Manufacturer	Installed	Mass		Lever Arm	
					lb	kg	in	m
ELT unit	ME406	453-6603	Artex		2.064	0.936	179.700	4.565
ELT unit	ELT1000	A3-062749-1, Kit (8209)	Artex		2.000	0.907	179.700	4.565
ELT remote switch		345-6196-04	Artex					
ELT antenna		110-773	Artex		0.251	0.114	152.800	3.880
USB charging port		6450202-9	Mid-Continent		0.050	0.023	70.080	1.780
USB charging port		6450202-9	Mid-Continent		0.050	0.023	70.080	1.780
Buzzer		452-6505	Artex					
Winter baffle		DA4-2157-00-00						
Nose gear tie-down		DA4-1001-00-00						
SAFETY EQUIPMENT								
Fire extinguisher		HAL 1	AIR Total					
Fire extinguisher, portable		337TS	Amerex		3.170	1.440	110.000	2.794
Fire extinguisher, portable ¹		A 620 T	Amerex					
First aid kit								
Emergency axe		G45912	Fiskars					
Emergency egress hammer		D64-2560-70-50	Diamond Aircraft					
Emergency egress hammer		D67-2560-80-50	Diamond Aircraft					
FLIGHT CONTROLS								
Flaps actuator assy		43055	Krutz					

Description	Type	Part No.	Manufacturer	Installed	Mass		Lever Arm	
					lb	kg	in	m
Flap control unit		DAI-9031-10-01	Krutz					
Stall warning horn assy	"A"	DA4-2739-10-00	Diamond Aircraft					
Stall warning horn assy	"B"	DA4-2739-10-00X01	Diamond Aircraft					
Stall warning horn assy	"C"	DA4-2739-10-00X02	Diamond Aircraft					
Stall warning horn assy	"D"	DA4-2739-10-00X03	Diamond Aircraft					
Stall warning horn assy	"E"	DA4-2739-10-00X04	Diamond Aircraft					
Stall warning horn assy	"F"	DA4-2739-10-00X05	Diamond Aircraft					
FUEL								
Fuel transfer pump		5100-00-9	Dukes Inc.					
Fuel transfer pump		18002-B	Weldon					
INDICATING / REC. SYSTEM								
Primary flight display (PFD)	GDU 1040	011-00972-03	Garmin		6.400	2.900	70.080	1.780
Primary flight display (PFD)	GDU 1040	011-00972-10	Garmin		6.400	2.900	70.080	1.780
Primary flight display (PFD)	GDU 1040	011-00972-02	Garmin		6.400	2.900	70.080	1.780
Primary flight display (PFD)	GDU 1050	011-03470-00	Garmin		6.400	2.900	70.080	1.780
Multi function display (MFD)	GDU 1044	011-01078-01	Garmin		6.400	2.900	70.080	1.780
Multi function display (MFD)	GDU 1044	011-01078-10	Garmin		6.400	2.900	70.080	1.780
Multi function display (MFD)	GDU 1040	011-00972-02	Garmin		6.400	2.900	70.080	1.780
Multi function display (MFD)	GDU 1040	011-00972-03	Garmin		6.400	2.900	70.080	1.780

Description	Type	Part No.	Manufacturer	Installed	Mass		Lever Arm	
					lb	kg	in	m
Multi function display (MFD)	GDU 1040	011-00972-10	Garmin		6.400	2.900	70.080	1.780
Multi function display (MFD)	GDU 1054	011-03470-60	Garmin		6.400	2.900	70.080	1.780
Flight timer		85094-12	Hobbs					
Digital chronometer with OAT	M803-28V		Davtron					
Annunciator panel		WW-IDC004	White Wire					
Chronometer		09CH	Adriatica					
HYDRAULIC								
Master cylinder		10-54A	Cleveland					
Parking valve		60-5D	Cleveland					
Brake assembly		30-239B	Cleveland					
Brake assembly		30-239A	Cleveland					
Brake assembly		30-32E	Cleveland					
Speedkit NLG		D44-3229-29-00_1	Diamond Aircraft					
LIGHTS								
Map / Reading light assy crew		W1461.0.010	Rivoret					
Cabin light		W1461.0.010	Rivoret					
Strobe / Pos. light assy LH	A600-PR-D-28	01-0790006-05	Whelen		0.800	0.363	103.800	2.638
Strobe / Pos. light assy LH	9034004	01-0790340-04	Whelen					
Strobe / Pos. light assy LH	OR6002R	01-0771733-12	Whelen					

Description	Type	Part No.	Manufacturer	Installed	Mass		Lever Arm	
					lb	kg	in	m
Strobe / Pos. light assy RH	A600-PG-D-28	01-0790006-07	Whelen		0.800	0.363	103.800	2.638
Strobe / Pos. light assy RH	9034003	01-0790340-03	Whelen					
Strobe / Pos. light assy RH	OR6002G	01-0771733-11	Whelen					
Strobe light power supply LH/RH	A490ATS-CF-14/28	01-0770062-05	Whelen		0.280	0.130	79.920	2.030
Halogen Taxi light	7034601	01-0770346-01	Whelen		0.280	0.130	79.920	2.030
Halogen Landing light	7034601	01-0770346-01	Whelen		0.280	0.130	79.920	2.030
Ballast	GEN5 D1, 24 V	37776	Newark					
Ballast	GEN5 D1, 24V	37776	Newark					
Taxi light	HID Lamp D1S	39663	Newark					
Landing light	HID Lamp D1S	39663	Newark					
LED Taxi light	71125	01-0771125-23	Whelen		0.300	0.140	79.920	2.030
LED Landing light	71125	01-0771125-20	Whelen		0.300	0.140	79.920	2.030
Glareshield lamp assy		DA4-3311-10-02	Diamond Aircraft					
Glareshield lamp assy		DA4-3311-10-01	Diamond Aircraft					
Glareshield light inverter		APVL328-4-1-L-5QF	Quantaflex					
Glareshield light inverter		APVL328-8-3-L-18QF	Quantaflex					
Placards inverter		APVL328-4-1-L-15QF	Quantaflex					
Map / reading light		RL6980-1	Birk Aerosystems					
Instr./ Radio lights dimmer		WW-LCM002	White Wire					

Description	Type	Part No.	Manufacturer	Installed	Mass		Lever Arm	
					lb	kg	in	m
COMMUNICATION / NAVIGATION								
COMM #1 antenna	DMC63-1/A		DM		0.400	0.180	177.100	4.500
COMM #1 antenna	CI 291		Comant		0.500	0.227	177.100	4.500
COMM #2 antenna	DMC63-2		DM		0.400	0.180	155.100	3.940
COMM #2 antenna	CI 292-2	011-00809-00	Comant		0.500	0.227	155.100	3.940
Audio panel / Marker / ICS	GMA 1347	011-00809-00	Garmin					
Audio panel / Marker / ICS	GMA 1360	011-03568-00	Garmin		1.860	0.840	70.080	1.780
Headset, pilot	Echelon 100		Telex					
Headset, pilot	HMEC25-KAP-2	025-230-715	Sennheiser					
Headset, co-pilot	Echelon 100		Telex					
Headset, co-pilot	HMEC25-KAP-2	025-230-715	Sennheiser					
Headset, LH pax	Echelon 100		Telex					
Headset, LH pax	HMEC25-KAP-2	025-230-715	Sennheiser					
Headset, RH pax	Echelon 100		Telex					
Headset, RH pax	HMEC25-KAP-2	025-230-715	Sennheiser					
Speaker	FRS8 / 4 Ohms		Visaton					
Handmic.	100 TRA	62800-001	Telex					
Pitot / Static probe, heated	AN5814-2	PST-305	Aeroinstruments					
Alternate static valve		DA4-3111-51-00	Diamond Aircraft					
Backup altimeter		5934PD-3	United Instruments		0.496	0.225	70.080	1.780

Description	Type	Part No.	Manufacturer	Installed	Mass		Lever Arm	
					lb	kg	in	m
Backup airspeed indicator	8025	8025 Code B.908	United Instruments		0.680	0.308	70.080	1.780
Backup artificial horizon	4300	4300-206	Mid Continent Instr.		2.500	1.134	70.080	1.780
Magnetic compass		PG2C-28V	SIRS Navigation					
Magnetic compass		NV2C-2400-28V	SIRS Navigation					
OAT probe	GTP 59	011-00978-00	Garmin					
Digital air data system	GDC 74A	011-00882-00	Garmin		1.690	0.770	70.080	1.780
Digital air data system	GDC 74A	011-00882-10	Garmin		1.690	0.770	70.080	1.780
Digital air data system	GDC 72	011-03734-00	Garmin					
Integrated avionics #1	GIA 63	37207	Garmin		5.290	2.400	154.900	3.935
Integrated avionics #1	GIA 63W	011-01105-01	Garmin		5.290	2.400	154.900	3.935
Integrated avionics #1	GIA 63W	011-01105-20	Garmin		5.290	2.400	154.900	3.935
Integrated avionics #1	GIA 63	011-00781-01	Garmin		5.290	2.400	154.900	3.935
Integrated avionics #1	GIA 64W	011-03711-00	Garmin		5.4	2.45	154.900	3.935
Integrated avionics #1	GIA 64W	011-03711-01	Garmin		5.4	2.45	154.900	3.935
Integrated avionics #2	GIA 63	37207	Garmin		5.290	2.400	154.900	3.935
Integrated avionics #2	GIA 63W	011-01105-01	Garmin		5.290	2.400	154.900	3.935
Integrated avionics #2	GIA 63W	011-01105-20	Garmin		5.290	2.400	154.900	3.935
Integrated avionics #2	GIA 63	011-00781-01	Garmin		5.290	2.400	154.900	3.935
Integrated avionics #2	GIA 64W	011-03711-00	Garmin		5.4	2.45	154.900	3.935
Integrated avionics #2	GIA 64W	011-03711-01	Garmin		5.4	2.45	154.900	3.935

Description	Type	Part No.	Manufacturer	Installed	Mass		Lever Arm	
					lb	kg	in	m
Transponder	GTX 33	011-00779-00	Garmin		5.290	2.400	154.900	3.935
Transponder	GTX 33	011-00779-10	Garmin		3.100	1.410	153.100	3.890
Transponder	GTX 335R	011-03301-00	Garmin		2.0	0.91	153.100	3.890
Transponder	GTX33ES	011-00779-30	Garmin		3.100	1.410	153.100	3.890
Transponder	GTX 345R	011-03303-00	Garmin		2.3	1.0	153.100	3.890
Transponder coupler		70-2040	Avidyne					
Attitude / Heading reference system GRS 77	GRS 77	011-00868-10	Garmin		2.800	1.270	154.900	3.935
Attitude / Heading reference system GRS 77	GRS 77	011-00868-00	Garmin		2.800	1.270	154.900	3.935
Attitude / Heading reference system	GRS 79	011-03732-00	Garmin		1.720	0.780	155.000	3.937
Data link processor	GDL 69A SXM	011-03177-10	Garmin		1.40	0.64	155.000	3.937
Data link processor	GDL 69A SXM	011-03177-15	Garmin		1.40	0.64	155.000	3.937
Magnetometer	GMU 44	011-00870-00	Garmin		0.350	0.160	103.800	2.638
Magnetometer	GMU 44	011-00870-10	Garmin		0.350	0.160	103.800	2.638
Magnetometer	GMU 44B	011-04201-00	Garmin		0.30	0.14	103.800	2.638
VOR/LOC/GS antenna	CI 157P		Comant					
Dual VOR/dual GS duplexer	CI 1125		Comant					
Transponder antenna	KA 60	071-01591-0001	Bendix/King					
Transponder antenna	KA 61	071-00221-0010	Bendix/King					
Marker antenna	CI 102		Comant					
GPS #1 antenna	GA 56	011-00134-00	Garmin		0.470	0.210	104.100	2.645

Description	Type	Part No.	Manufacturer	Installed	Mass		Lever Arm	
					lb	kg	in	m
GPS #1 antenna	GS 36	013-00244-00	Garmin		0.470	0.210	104.100	2.645
GPS #2 antenna	GA 56	011-00134-00	Garmin		0.470	0.210	104.100	2.645
GPS #2 antenna	GA 36	013-00244-00	Garmin		0.470	0.210	104.100	2.645
DME	KN 63	066-1070-01	Bendix/King		2.800	1.270	141.100	3.580
DME antenna	KA 60	071-01591-0001	Bendix/King					
DME antenna	KA 61	071-00221-0010	Bendix/King					
Stormscope	WX-500	805-11500-001	L-3					
Stormscope antenna	NY-163	805-10930-001	L-3					
ADF receiver	RA 3502-(01)	0505.757-912	Becker					
ADF/RMI converter	AC 3504-(01)	0856.010-912	Becker					
ADF antenna	AN3500	0832.601-912	Becker					
TAS processor	TAS 600	70-2420-x TAS 600	Avidyne/Ryan					
TAS processor	TAS 600A	700-00185-000	Avidyne					
TAS processor	TAS 605	70-2420-x TAS 605	Avidyne/Ryan					
TAS processor	TAS 605A	700-00185-001	Avidyne					
TAS processor	TAS 610	70-2420-x TAS 610	Avidyne/Ryan					
TAS processor	TAS615A	700-00185-003	Avidyne					
TAS processor	TAS620A	700-00185-004	Avidyne					
Transponder coupler		70-2040	Avidyne/Ryan					
TAS antenna, top		S72-1750-31L	Sensor Systems					
TAS antenna, bottom		S72-1750-32L	Sensor Systems					

Description	Type	Part No.	Manufacturer	Installed	Mass		Lever Arm	
					lb	kg	in	m
COM/NAV	SL 30	430-6040-303	Garmin					
Intercom	PM1000II	11922	PS Engineering					
Transponder	GTX 328	011-01684-00	Garmin					
Altitude digitizer	SAE5-35	305154-00	Sandia Aerospace					
P/S probe heater fail sensor		DA4-3031-01-00	Diamond Aircraft					
Altimeter inHg/mbar, primary		5934PD-3	United Instruments					
Altimeter inHg/mbar, secondary		5934PD-3	United Instruments					
Airspeed indicator		8025 Code B.908	United Instruments					
Vertical speed indicator		7000	United Instruments					
Magnetic compass		C2400L4P	Airpath					
Directional gyro, free	AIM2051BLD	505-0031-931	L-3 Communications					
Attitude indicator	AIM1100-28L(0F)	504-0111-936	L-3 Communications					
Attitude indicator	AIM1100-28LK(0F)	504-0111-938	L-3 Communications					
Attitude indicator	AIM1100-28LK(2F)	504-0111-941	L-3 Communications					
Standby attitude module	MD302	6420302-2	Mid Continent Instr		1.600	0.730	70.080	1.780
Turn coordinator	1394T100-3Z		Mid Continent					
Turn coordinator	1394T100-12RB		Mid Continent					
GPS antenna	GA56	011-00134-00	Garmin					

Description	Type	Part No.	Manufacturer	Installed	Mass		Lever Arm	
					lb	kg	in	m
ENGINE								
Engine	E4	E4A-00-000-000	Austro Engine					
Engine	E4	E4A-00-000-AHY	Austro Engine					
Engine	E4	E4A-00-000-BHY	Austro Engine					
Engine control unit	EECU-E4-01	E4A-92-100-000 Iss: 02()	Austro Engine					
ECU software		Refer to DAI Service Bulletin MSB-40NG- 002	Austro Engine					
ENGINE STARTING								
Glow plug control unit		E4A-94-200-000	Austro Engine					
Starter		E4A-93-000-000	Austro Engine					
ELECTRICAL POWER								
Alternator		E4A-91-000-000	Austro Engine					
Alternator		E4A-91-400-000	Austro Engine					
Alternator regulator		E4A-91-100-000	Austro Engine					
Alternator regulator		E4A-91-200-000	Austro Engine					
ENGINE FUEL PUMPS								
Fuel pumps (2x)		0-580-054-001	Bosch					

Description	Type	Part No.	Manufacturer	Installed	Mass		Lever Arm	
					lb	kg	in	m
ENGINE INDICATING								
Engine / Airframe unit	GEA 71	011-00831-00	Garmin					
Engine / Airframe unit	GEA 71B	011-03682-00	Garmin		1.800	0.820	70.080	1.780
Main engine display		A1A-10-100-000-010	Austro Engine					
Secondary engine display		A1A-10-200-000-010	Austro Engine					
ENGINE EXHAUST								
Exhaust pipe		D44-7806-10-01	Diamond Aircraft					
Exhaust pipe with muffler		D44-7806-20-00	Diamond Aircraft					
Exhaust pipe with muffler		D44-7806-20-00_1	Diamond Aircraft					
Exhaust pipe with muffler		D44-7806-20-00_2	Diamond Aircraft					
PROPELLER								
Propeller	MTV-6-R/190-69		mt-propeller					
Governor		P-853-16	mt-propeller					
FUEL TANK SYSTEM								
Fuel probe assy., LH inboard		D4D-2817-13-00x01	Diamond Aircraft					
Fuel probe assy., RH inboard		D4D-2817-13-00x01	Diamond Aircraft					
Alternate means for fuel qty.		D4D-2807-90-00	Diamond Aircraft					

Description	Type	Part No.	Manufacturer	Installed	Mass		Lever Arm	
					lb	kg	in	m
Alternate means for fuel qty. II		D4D-2807-90-00_01	Diamond Aircraft					
Long range tank		D4D-2807-11-00	Diamond Aircraft					
Long range tank		D4D-2807-12-00	Diamond Aircraft					
Standard tank		D4D-2817-11-00	Diamond Aircraft					
Standard tank		D4D-2817-12-00	Diamond Aircraft					
LANDING GEAR								
<i>LANDING GEAR STANDARD FAIRINGS</i>								
MLG wheel fairing LH		D41-3213-91-00	Diamond Aircraft					
MLG wheel fairing RH		D41-3213-92-00	Diamond Aircraft					
NLG wheel pant shell LH		D41-3223-91-00_1	Diamond Aircraft					
NLG wheel pant shell RH		D41-3223-92-00_1	Diamond Aircraft					
<i>LANDING GEAR SPEEDKIT</i>								
MLG speed cover LH		DA4-3219-27-00_1	Diamond Aircraft					
MLG speed cover RH		DA4-3219-28-00_1	Diamond Aircraft					
MLG sheet cover LH		DA4-3219-25-00	Diamond Aircraft					
MLG sheet cover RH		DA4-3219-26-00	Diamond Aircraft					
MLG cover speed LH		DA4-3219-21-00	Diamond Aircraft					
MLG cover speed RH assembly		D4D-3219-12-00	Diamond Aircraft					
MLG strut cover LH (heavy landing)		D44-3216-23-00	Diamond Aircraft					



Description	Type	Part No.	Manufacturer	Installed	Mass		Lever Arm	
					lb	kg	in	m
MLG strut cover RH (heavy landing)		D44-3219-24-00	Diamond Aircraft					
NLG wheel pant shell LH		D41-3223-91-00_1	Diamond Aircraft					
NLG wheel pant shell RH		D41-3223-92-00_1	Diamond Aircraft					
NLG strut cover (heavy landing)		D44-3229-29-00	Diamond Aircraft					
NLG mounting sheet assy		DA4-3229-30-00	Diamond Aircraft					
AIRPLANE FLIGHT MANUAL		Doc. No. 6.01.15-E	Diamond Aircraft					

¹ The Amerex A620T is UL approved and can be used in aircraft registered in Canada and the USA. For aircraft registered in other countries, contact the local airworthiness authority.

Place: _____ Date: _____ Signature: _____

CHAPTER 7 DESCRIPTION OF THE AIRPLANE AND ITS SYSTEMS

Page

7.1	INTRODUCTION	7-3
7.2	AIRFRAME	7-3
	7.2.1 FUSELAGE	7-3
	7.2.2 WINGS	7-3
	7.2.3 EMPENNAGE	7-3
7.3	FLIGHT CONTROLS	7-4
	7.3.1 AILERONS	7-4
	7.3.2 FLAPS	7-5
	7.3.3 ELEVATOR	7-7
	7.3.4 RUDDER	7-7
	7.3.5 ELEVATOR TRIM	7-8
	7.3.6 PEDAL ADJUSTMENT	7-8
7.4	INSTRUMENT PANEL	7-10
	7.4.1 COCKPIT VENTILATION	7-14
	7.4.2 HEATING	7-14
	7.4.3 STANDBY ATTITUDE MODULE	7-16
7.5	LANDING GEAR	7-17
	7.5.1 WHEEL BRAKES	7-17
	7.5.2 PARKING BRAKE	7-17
7.6	SEATS AND SAFETY HARNESSSES	7-19
7.7	BAGGAGE COMPARTMENT	7-23
7.8	CANOPY, REAR DOOR, AND CABIN INTERIOR	7-23
	7.8.1 FRONT CANOPY	7-23
	7.8.2 REAR DOOR	7-24
	7.8.3 EMERGENCY AXE	7-25

	7.8.4	EMERGENCY EGRESS HAMMER.....	7-26
	7.8.5	FIRE EXTINGUISHER	7-27
7.9		POWER PLANT.....	7-27
	7.9.1	ENGINE, GENERAL	7-27
	7.9.2	OPERATING CONTROLS	7-28
	7.9.3	PROPELLER.....	7-31
	7.9.4	FUEL SYSTEM	7-33
	7.9.5	COOLING SYSTEM	7-45
	7.9.6	TURBOCHARGER SYSTEM	7-46
	7.9.7	OIL SYSTEMS	7-47
7.10		ELECTRICAL SYSTEM.....	7-48
	7.10.1	GENERAL	7-49
	7.10.2	ENGINE CONTROL UNIT / ECU	7-56
7.11		PITOT-STATIC SYSTEM.....	7-58
7.12		STALL WARNING SYSTEM	7-58

7.1 INTRODUCTION

Chapter 7 contains a description of the airplane and its systems, together with operating instructions.

For details about optional equipment see Chapter 9.

7.2 AIRFRAME

7.2.1 FUSELAGE

The GFRP fuselage is of semi monocoque molded construction. The fire protection on the firewall is of a special fire-resistant matting, which is covered on the engine side by stainless steel cladding. The two main bulkheads are GFRP/CFRP items.

7.2.2 WINGS

The wings have a front and rear spar; each wing has a top shell and a bottom shell - a “fail safe” concept. The wings, as well as the ailerons and flaps, are made of GFRP/CFRP, and are principally of sandwich construction. An aluminum fuel tank is installed in each of the wings.

7.2.3 EMPENNAGE

The airplane has a T-tail of GFRP semi monocoque construction. Both the stabilizers have twin spars and a skin with no sandwich. The rudder and elevator are of sandwich construction.

7.3 FLIGHT CONTROLS

The ailerons, elevator and wing flaps are operated through control rods, while the rudder is controlled by cables. The flaps are electrically operated. Elevator forces can be balanced by a trim tab on the elevator, which is operated by a Bowden cable.

7.3.1 AILERONS

Construction: GFRP/CFRP composite sandwich.

Hinges: There are 4 hinges, which are hinge pins mounted in an aluminum bracket. They are secured in position by a roll pin. The absence of this roll pin can lead to the loss of the hinge pin and a consequent loss of flight safety.

Operation: A rod-end bearing is screwed into a steel push rod and locked by means of a jam nut which has locking varnish applied to it. Damage to this varnish can indicate a twisting and thus a change to the adjustment. The connection between the rod-end bearing and the control horn is a bolt, the nut of which is likewise sealed with locking varnish.

The aluminum control horn is attached to the aileron with 3 screws.

I 7.3.2 FLAPS

Construction: GFRP/CFRP composite sandwich.

Hinges: There are 6 hinges, which are hinge pins mounted in an aluminum bracket. They are secured in position by a roll pin. The absence of this roll pin can lead to the loss of the hinge pin and a consequent loss of flight safety. Another aluminum fitting is located at the fuselage and is attached to a torsion tube. The torsion tube is located in the fuselage, creating a connection between the left and right flaps.

Operation: A rod-end bearing is screwed into a steel push rod and locked by means of a jam nut which has locking varnish applied to it. Damage to this varnish can indicate a twisting and thus a change to the adjustment. The connection between the rod-end bearing and the control horn is a bolt, the nut of which is likewise sealed with locking varnish.

The flap control horn is attached to the flap with 3 screws.

The flaps are driven by an electric motor and have 3 settings:

- Cruise (UP), totally retracted
- Take-off (T/O), and
- Landing (LDG).

The flaps are operated by means of a 3-position flap selector switch on the instrument panel. The positions of the switch correspond to the positions of the flaps, the cruise position of the switch being at the top. If the switch is moved to another position, the flaps continue to travel automatically until they have reached the position selected on the switch. The UP and LDG positions are additionally protected by a limit switch to guard against over-running the end positions.

The electrical flap drive has an automatic circuit breaker which can also be operated manually.

Flap Position Indicator:

The current flap position is indicated by means of three lights beside the flap selector switch.

When the upper light (green) is illuminated, the flaps are in the cruise position (UP);

- when the center light (white) is illuminated, the flaps are in the take-off position (T/O);
- when the lower light (white) is illuminated, the flaps are in the landing position (LDG).

When two lights are illuminated simultaneously, the flaps are between the two indicated positions. This is the case only when the flaps are traveling.

7.3.3 ELEVATOR

Construction: GFRP sandwich.

Hinges: 5 hinges.

Operation: Steel push-rods;

Two of the bellcrank bearings are accessible to visual inspection next to the lower hinge of the rudder. The elevator horn and its bearing, as well as the connection to the push-rod, can be visually inspected at the upper end of the rudder.

7.3.4 RUDDER

Construction: GFRP sandwich.

Hinges: Upper hinge: One bolt.

Lower hinge: Bearing bracket including rudder stops, held by 4 screws to the rear web of the vertical stabilizer. The mating part on the rudder is a bracket which is attached to the rudder by 2 bolts. The bolts and nuts are accessible to visual inspection.

Operation: Steel cables, the eyes of which are connected to the bolts on the bracket.

7.3.5 ELEVATOR TRIM

The trim control is a black wheel in the center console to the rear of the power lever. To guard against over-rotating, the trim wheel incorporates a friction device. A mark on the wheel shows the take-off (T/O) position.

Turn wheel to the front = nose down

Turn wheel to the rear = nose up

7.3.6 PEDAL ADJUSTMENT**NOTE**

The pedals are unlocked by pulling the black T-grip handle, which is located behind the rear attachment, straight back.

The pedals may only be adjusted on the ground.

(a) Forward Adjustment:

Whilst keeping the handle pulled, push the pedals forward with your feet. Release the handle and allow the pedals to lock into place.

(b) Rearward Adjustment:

Using the unlocking handle, pull the pedals back to the desired position. Release the handle and push the pedals forward with your feet until they lock into place.

█ (c) Electrical Pedal Adjustment (Optional Equipment, OÄM 40-251):

█ **NOTE**

█ The pedals may only be adjusted on the ground.

█ The pedals are adjusted using a rocker switch, located on the floor side panel in the leg room.

█ The related circuit breaker is located above the switch.

█ *Forward adjustment*

█ To move the pedals forward, depress the front side of the switch. When the pedals are in the correct position, release the switch.

█ *Rearward adjustment*

█ To move the pedals rearward, depress the rear side of the switch. When the pedals are in the correct position, release the switch.

█ *Locking*

█ Upon release, the switch moves automatically to the “power off” position, locking the pedals in position.

7.4 INSTRUMENT PANEL

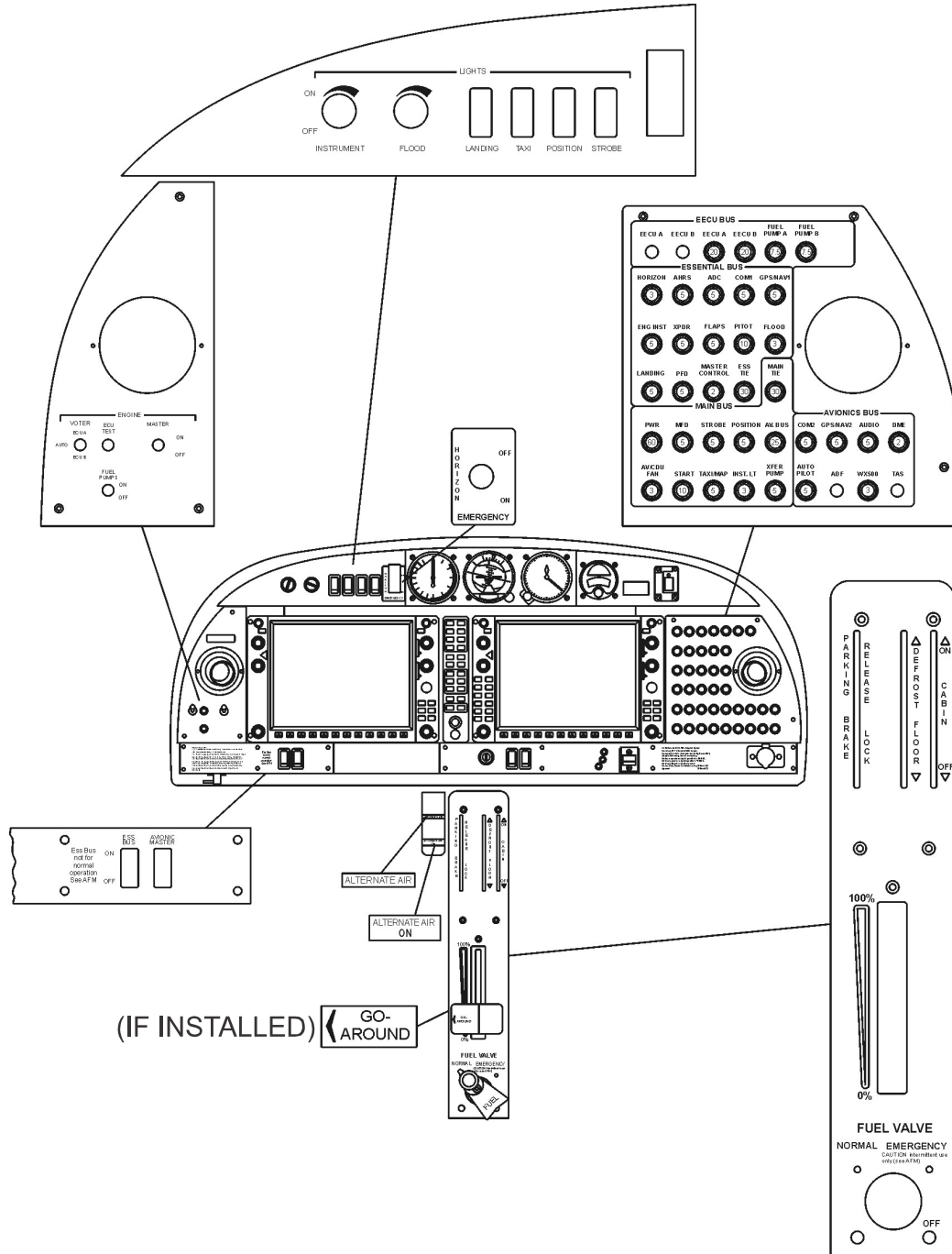

Instrument Panel with G1000

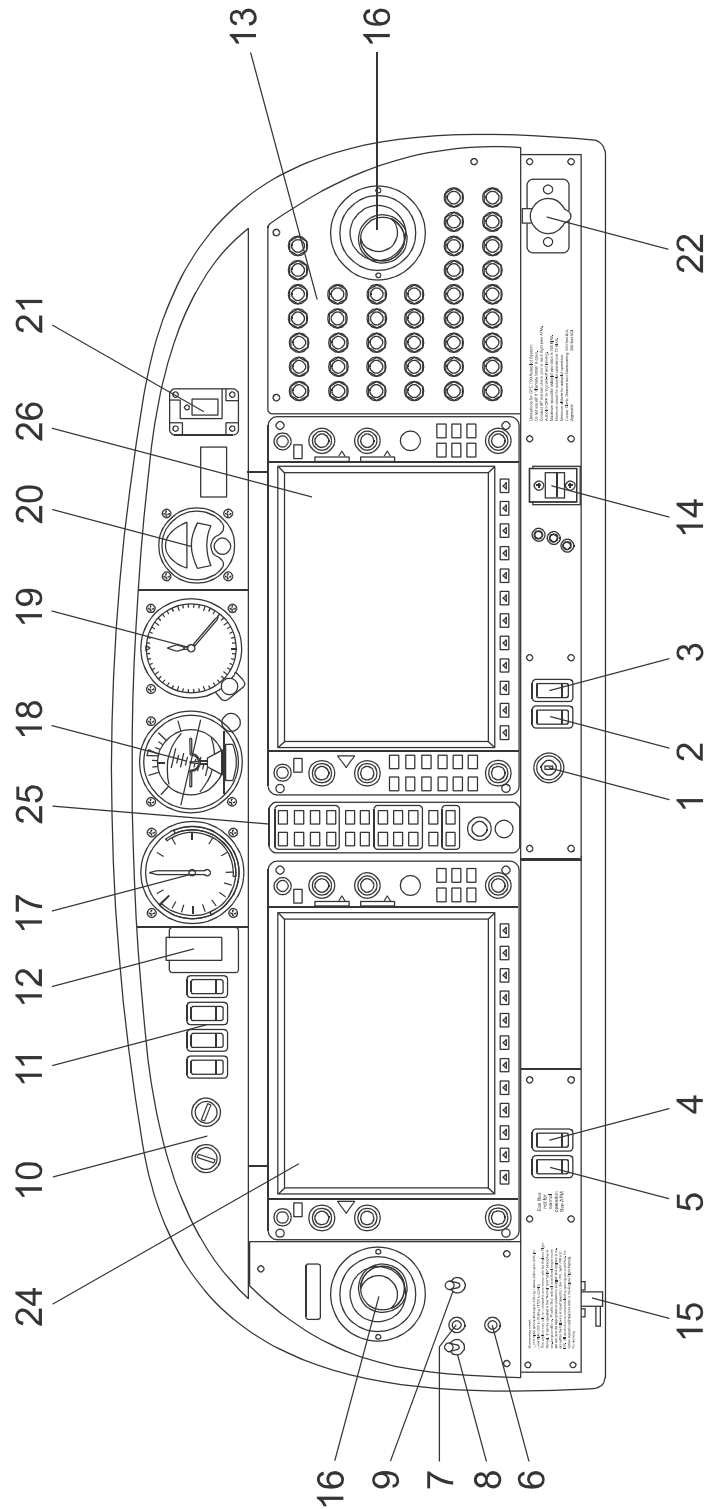

Instrument Panel with G1000

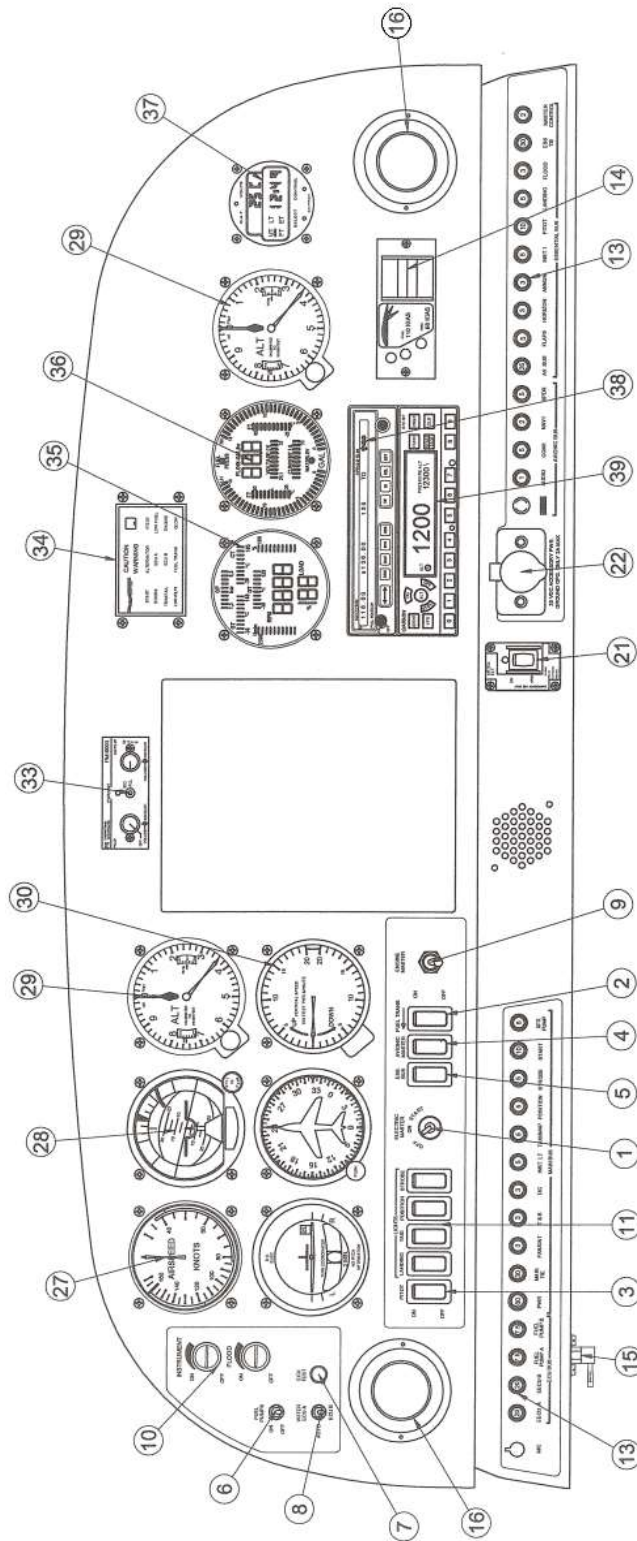

Instrument Panel with SED, MED and White Wire Annunciator Panel

Major Instruments and Controls			
1	Electric Master key switch	21	ELT control unit
2	Fuel Transfer switch	22	Accessory power socket
3	Pitot Heat switch		
4	Avionics Master switch	24	Primary Flight Display (PFD)
5	Essential Bus switch	25	Audio amplifier / Intercom / Marker beacon receiver
6	Fuel pumps switch	26	Multi Function Display (MFD)
7	ECU Test button	27	Airspeed Indicator
8	ECU Voter switch	28	Attitude Gyro (artificial horizon)
9	Engine Master switch**	29	Altimeter
10	Rotary buttons for instrument lighting and flood light	30	Vertical Speed Indicator (VSI)
11	Light switches	31	Directional Gyro
12	Emergency switch**	32	Turn & Bank indicator
13	Circuit breakers*	33	Intercom
14	Flap selector switch	34	Annunciator panel
15	Alternate static valve	35	Main Engine Display (MED)
16	Ventilation nozzles	36	Secondary Engine Display (SED)
17	Backup airspeed indicator	37	Chronometer with OAT Indicator
18	Backup artificial horizon	38	COM/NAV
19	Backup altimeter	39	Transponder
20	Emergency compass		

*) Designations and abbreviations used to identify the circuit breakers are explained in Section 1.5 - DEFINITIONS AND ABBREVIATIONS of the AFM.

**) The Emergency switch and optionally the Engine Master switch are guarded. Lift the guard prior to actuating the toggle. After switching, lower the Engine Master switch guard with the toggle in the desired position. Do not lower the Emergency switch guard with the toggle in the ON position.

NOTE

The figures on the previous pages show the typical DA 40 NG installation position for the equipment. The actual installation may vary due to the approved equipment version.

7.4.1 COCKPIT VENTILATION

Ventilation in the front is provided by the movable ventilation nozzles (16) in the instrument panel. Furthermore there are spherical nozzles in the roll bar on the left and right side next to the front seats as well as on the central console above the passengers' heads. The spherical nozzles are opened and closed by twisting.

Unconditioned ambient air is supplied to the interior through an inlet on the bottom surface of the left wing. To increase cabin temperatures when operating at low outside air temperatures, a ventilation inlet baffle may be installed at the inlet. With the baffle installed, the rear cabin ventilation nozzles on the left and right hand side and in the central console above the passengers' heads will be inoperative.

The ventilation inlet baffle consists of a metal plate with rubber edging and is attached to the bottom LH wing by a camloc.

7.4.2 HEATING

Heating is operated using two levers located on the small center console under the instrument panel.

Right lever:

up = heating ON
down = heating OFF

Central lever (air distribution lever):

up = airflow to canopy (DEFROST)
down = airflow to floor (FLOOR)

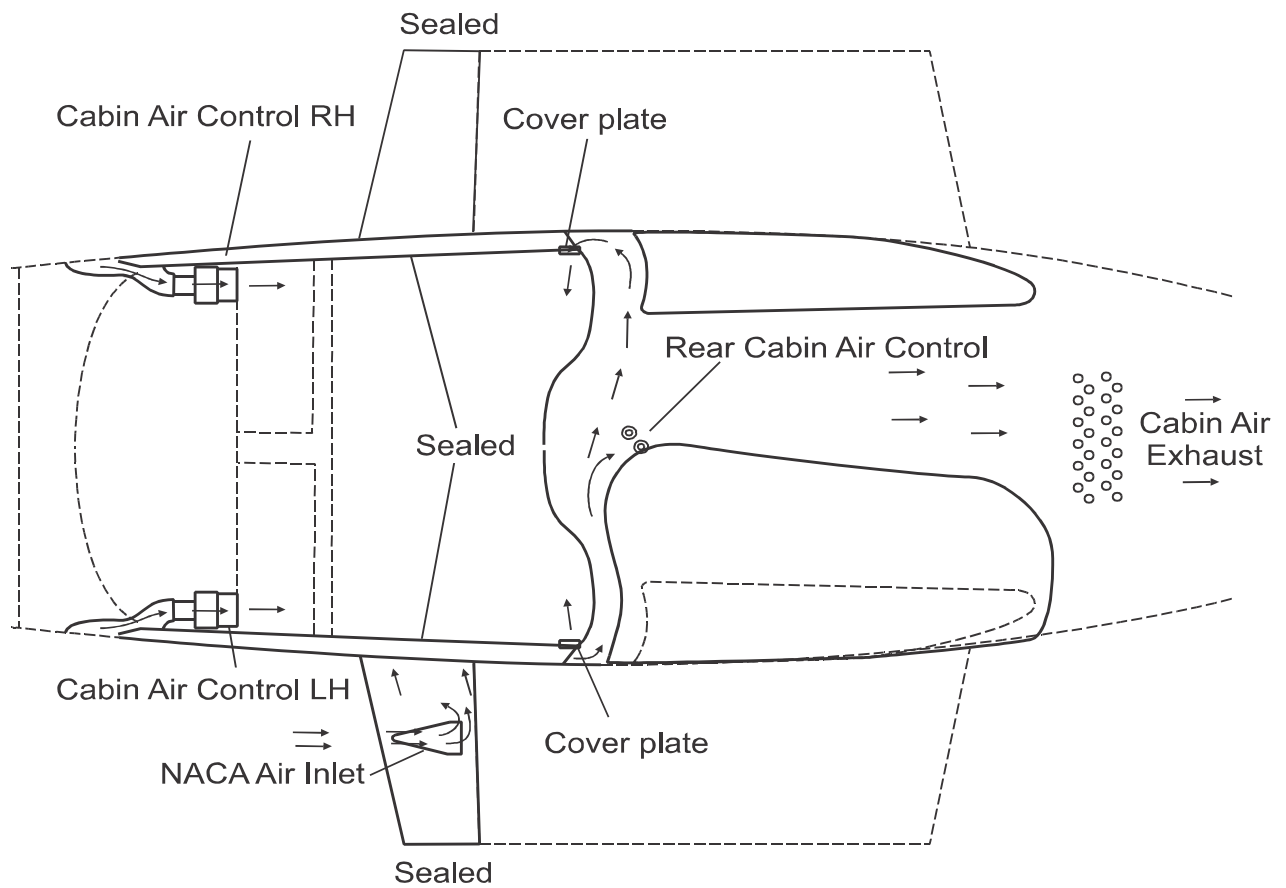
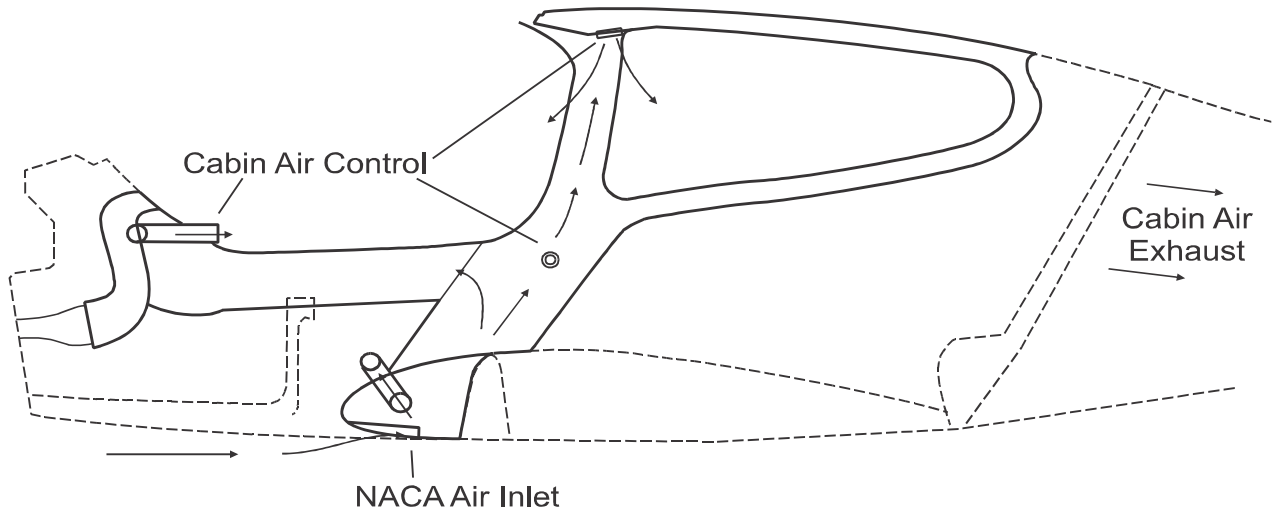

7.4.3 MD302 STANDBY ATTITUDE MODULE

When installed (via OAM 40-1029) The Mid Continent MD302 Standby Attitude Module is a self-contained situational awareness instrument that provides airplane attitude, altitude, airspeed, and slip indication in lieu of the analogue standby instruments.

The Standby Attitude Module consists of two separate LCD displays. One display serves as the artificial horizon, and the other serves as an airspeed indicator and altimeter. The user interface of the Standby Attitude Module allows for simple, intuitive operation using a single push-and-turn control knob.



Refer to the Mid Continent MD302 Standby Attitude Module Pilot's Guide P/N 9017846, latest effective issue, for more information.

The MD302 Standby Attitude Module is not connected to an external ARINC 429 source, thus heading information and automatic BARO synchronization is not available in the DA 40 NG.

7.5 LANDING GEAR

The landing gear consists of a main landing gear of spring steel struts, and a free-castering nose wheel which is spring-loaded by an elastomer package.

The wheel fairings are removable. When flying without wheel fairings, it should be noted that there is a reduction in some areas of performance (see Chapter 5).

7.5.1 WHEEL BRAKES

Hydraulically operating disk brakes act on the wheels of the main landing gear. The wheel brakes are individually operated by means of toe pedals.

7.5.2 PARKING BRAKE

The parking brake lever is located on the small center console under the instrument panel, and is in the upper position when the brakes are released. To operate the parking brake pull the lever downwards until it catches. Brake pressure is built up by multiple operation of the toe brake pedals, and is maintained until the parking brake is released. To release, apply toe pressure to the brakes, and push the lever upwards.

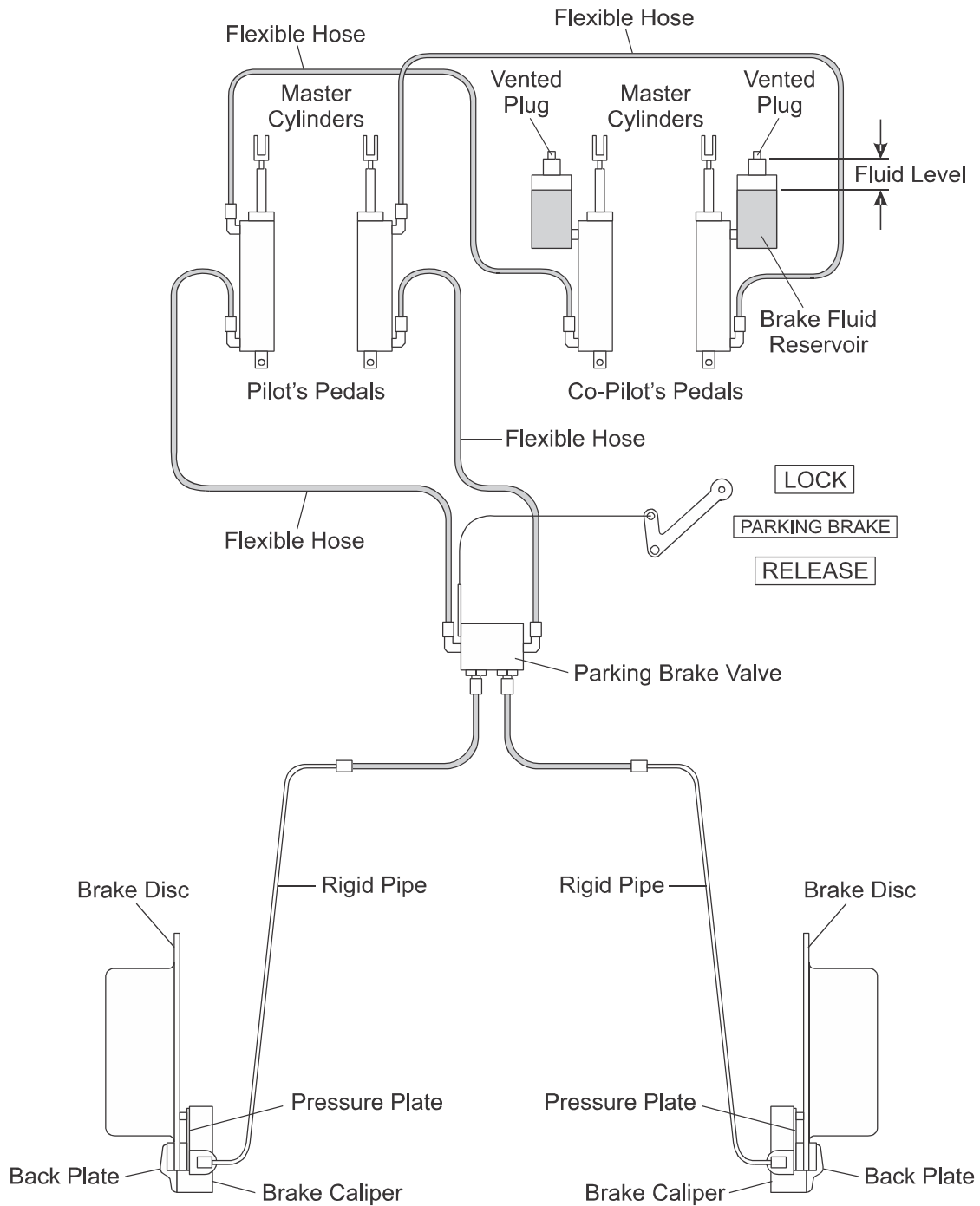

Hydraulic System Schematic

7.6 SEATS AND SAFETY HARNESSSES

To increase passive safety, the seats are constructed using a carbon fiber/Kevlar hybrid material and GFRP. The seats are removable to allow the maintenance and inspection of the underlying controls. Covers on the control sticks prevent loose objects from falling into the area of the controls.

The seats have removable furnishings and are equipped with energy-absorbing foam elements.

The seats are fitted with three-point safety harnesses. The harnesses are fastened by inserting the belt clip into the belt lock, and are opened by pressing the release on the belt lock.

The backs of the rear seats can be laid forward after pulling upwards on the knob of the locking bolt.

If front seats with adjustable backrests are installed (OÄM 40-252 or OÄM 40-375), the angle of the backrest, and the lumbar support, can be adjusted for best comfort. The backrest control lever is situated on the outboard side of the backrest if OÄM 40-252 is installed. The backrest release button in the case of OÄM 40-375, is situated on the upper side of the seat's side frame. However, during take-off, landing and emergency landings, the backrests must be fixed in the upright position designated by a placard on the roll-over bar.

The lumbar support can be adjusted by operating the lumbar support lever mounted on the outboard side of the seat pan.

CAUTION

Before the backrest lever is lifted in order to unlock the backrest, lean back towards the backrest to counteract the spring load; otherwise the backrest may snap forward.

CAUTION

Before adjusting the angle, lean against the backrest to counteract the spring load. Otherwise, the backrest may snap forward.

CAUTION

Do not apply a load of more than 90 N (202 lbf) to the top of the backrest. Otherwise, damage to the adjustment mechanism may result.

For adjustment lift the backrest lever, or press the button, and bend the backrest forward or backward to the desired backrest angle. For fixing the position, press down the backrest lever, or release the button.

If OÄM 40-252 is installed, and in case of a defective adjustment mechanism, the outboard friction adjustment screw can be tightened with a 10 mm hexagon nut in clockwise direction to fix the backrest in the upright position.

If possible, set the backrest lever to the locked position. The mechanism must be repaired at the next scheduled inspection.

If OÄM 40-375 is installed, and in case of a malfunction of the release button, the backrest can be moved into the upright position by pulling (480 N) the backrest forward.

If seats with adjustable backrests are installed (OÄM 40-252):

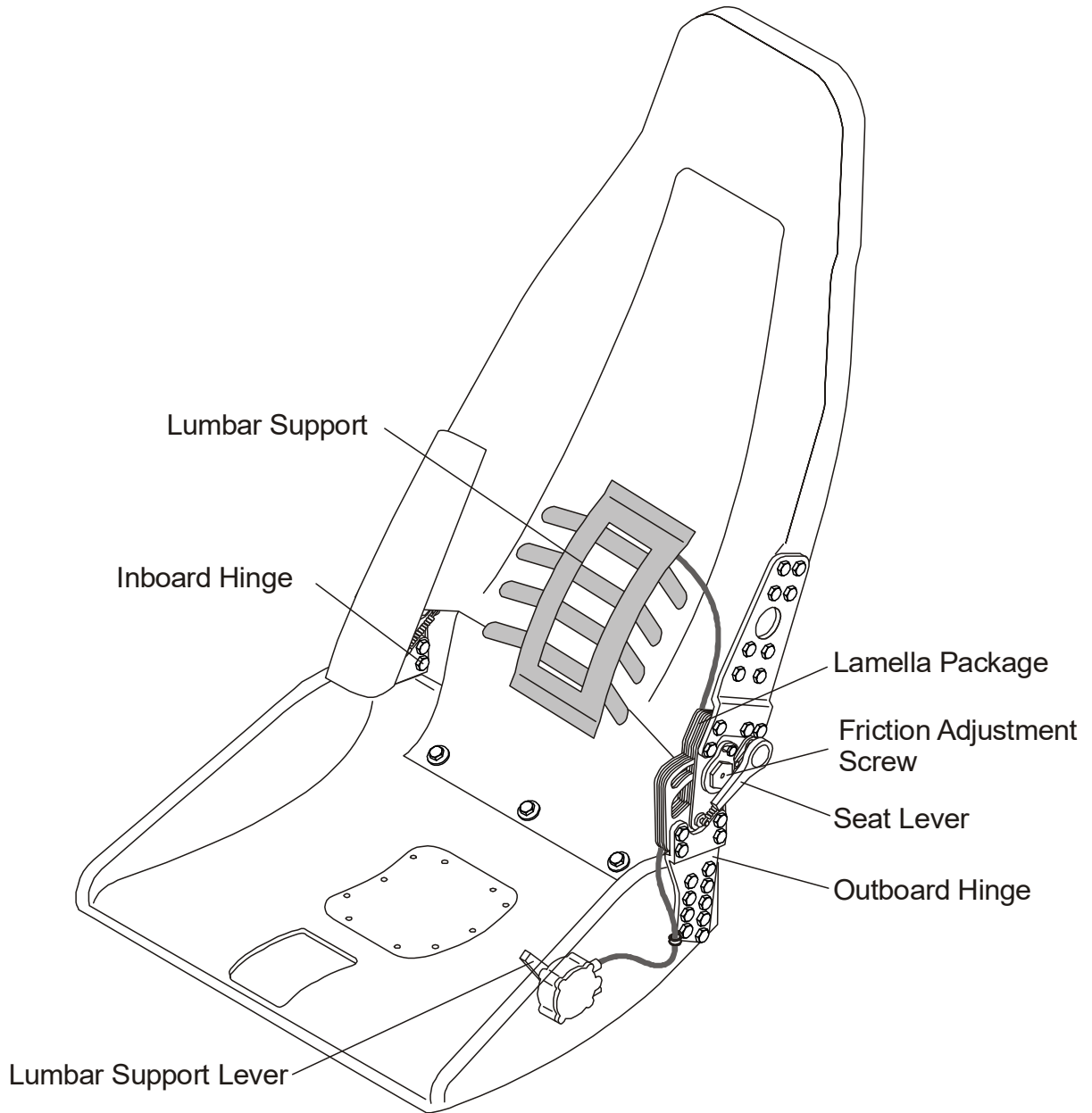

If seats with adjustable backrest - Hydrolok are installed (OÄM 40-375):

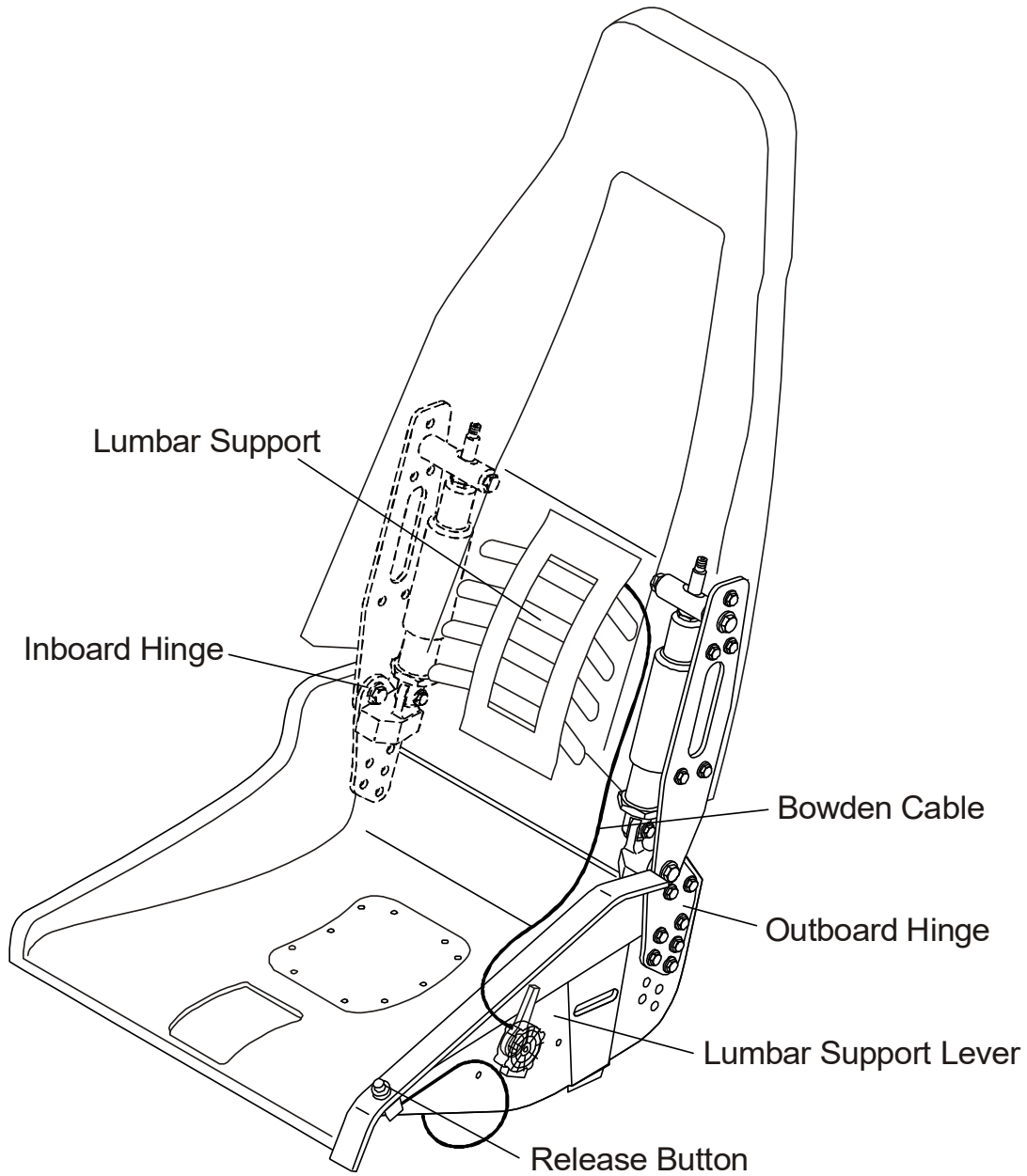

7.7 BAGGAGE COMPARTMENT

The baggage compartment is behind the seat backs of the rear seats. Without a baggage net, no baggage may be loaded.

As options, a baggage tube or a baggage extension (OÄM 40-164) or a short baggage extension (OÄM 40-331) may be installed.

NOTE

If OÄM 40-331 is installed, make sure that the baggage does not block the air vents in the back wall of the short baggage extension.

7.8 CANOPY, REAR DOOR, AND CABIN INTERIOR

7.8.1 FRONT CANOPY

The front canopy is closed by pulling down on the canopy frame and locking it with the handle on the left hand side of the canopy frame. On locking, steel bolts catch into mating holes in polyethylene blocks.

“Cooling gap” position: A second setting allows the bolts to lock in, leaving a gap under the forward canopy.

The canopy can be key-locked by a locking mechanism on the left side near the canopy lever by turning the key clockwise. The closed and locked canopy can be opened from inside by pulling the lever inside the opening handle.

WARNING

The airplane may be operated with the front canopy in the “cooling gap” position on the ground only. Before take-off the front canopy must be completely closed and latched, but not key-locked.

Do not key-lock the front canopy before flight to assure emergency evacuation from outside.

A window on the left and right hand side of the canopy can be opened for additional ventilation or as an emergency window.

7.8.2 REAR DOOR

The rear door is closed in the same way, by pulling down on the frame and locking it with the handle. A gas pressure damper prevents the door from dropping; in strong winds the assembly must be held. The rear door is protected against unintentional opening by an additional lever.

The door can be locked by a locking mechanism on the left side near the door opening lever by turning the key clockwise. The closed and locked door can be opened from inside by pulling

the lever inside the opening handle. For better handling an additional handle is mounted.

WARNING

Before starting the engine the door must be closed and latched, but not key-locked.

Do not key-lock the door before flight in order to assure emergency evacuation from outside.

7.8.3 EMERGENCY AXE

If OÄM 40-326 is incorporated with an emergency axe or on the floor panel under the co-pilot's seat (see Figure below).

If the canopy can not be opened in case of an emergency use the emergency axe to break through the canopy.

WARNING

Make sure not to harm any person by using the emergency axe.

WARNING

Beware of sharp edges and fragments of the broken canopy.

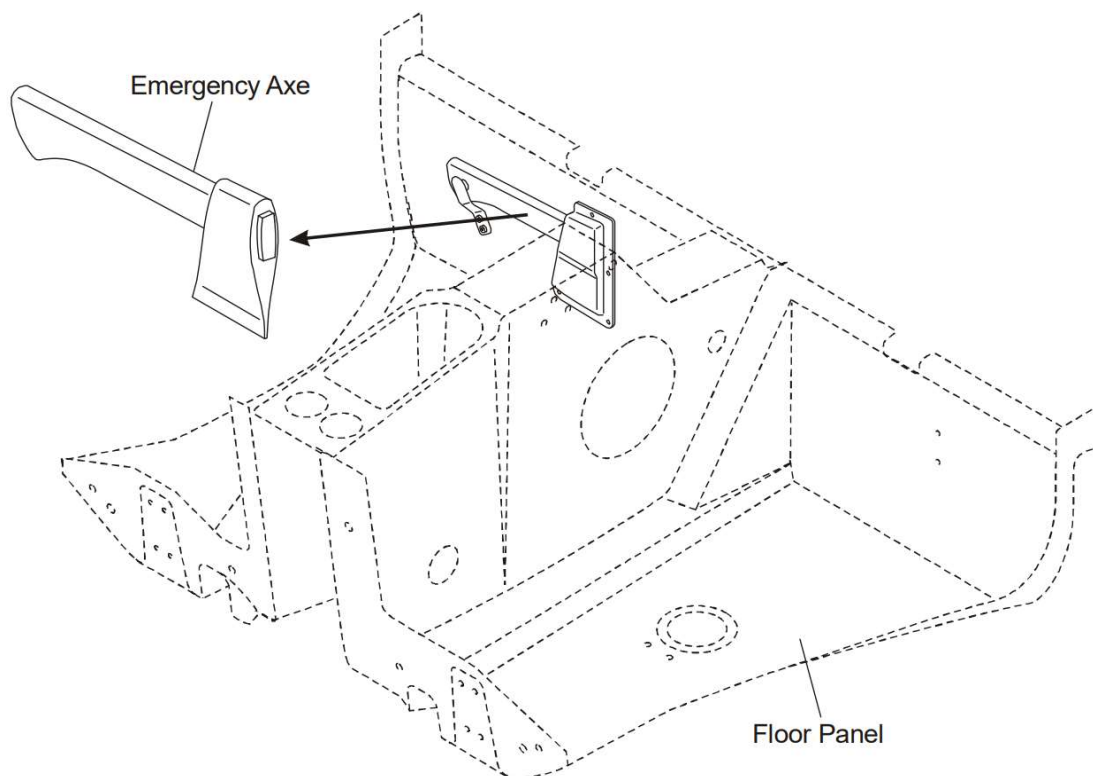

7.8.4 EMERGENCY EGRESS HAMMER

If OÄM 40-401 is incorporated, the emergency egress hammer is installed on the floor panel under the co-pilot's seat.

If the canopy cannot be opened in case of an emergency, use the emergency egress hammer to break through the canopy.

WARNING

Make sure not to harm other persons by using the emergency egress hammer.

WARNING

Beware of sharp edges and fragments of the broken canopy.

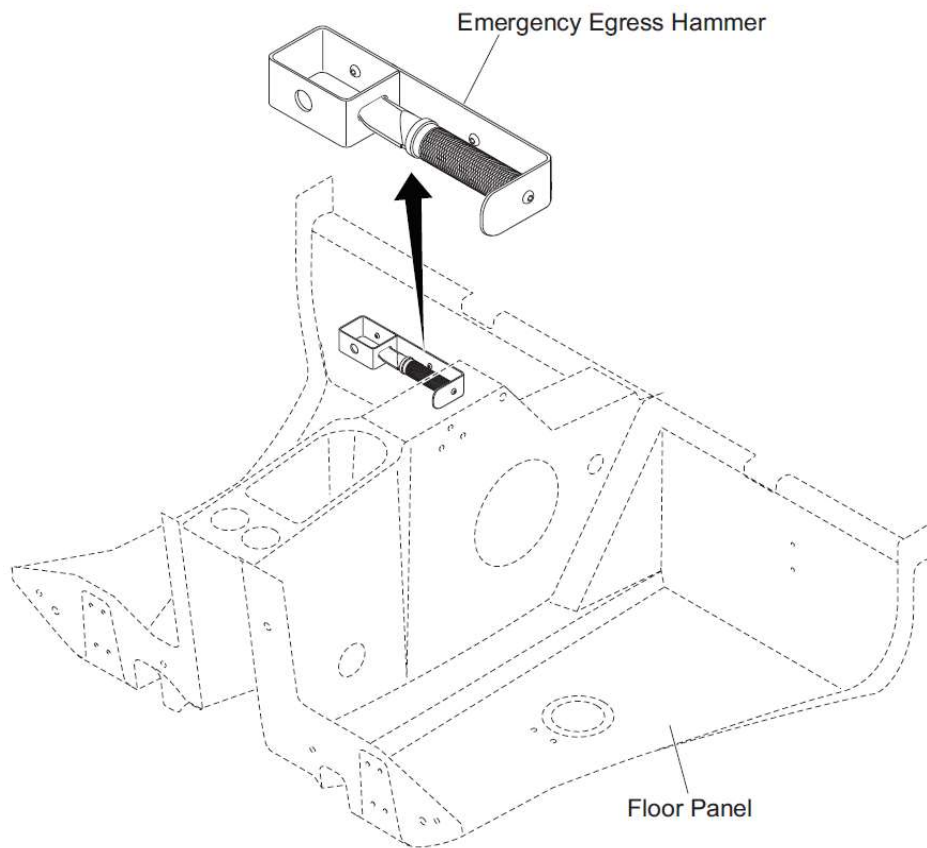

7.8.5 FIRE EXTINGUISHER

The Hal 1 fire extinguisher is located behind the co-pilot's seat. Screws attach the extinguisher mounting bracket to the closing rib between the front and the rear main bulkhead. The extinguisher uses a liquid gas which is non-toxic and does not have a residue.

With MÄM 40-1162 installed, the Amerex 337TS fire extinguisher is installed horizontally (fore/aft) on the side floor behind the co-pilot seat. The fire extinguisher is held into the bracket with a quick release metal straps. Screws, washers and nuts attach the extinguisher mounting bracket to the floor. The fire extinguisher utilizes Halotron BrX (2-BTP) as the extinguishing agent, which is non-toxic and does not have a residue.

7.9 POWER PLANT

7.9.1 ENGINE, GENERAL

The installed Austro Engine E4-A engine has the following specifications:

- Liquid-cooled four-cylinder four-stroke engine with wet sump lubrication
- Inline construction
- Common rail direct injection
- Propeller speed reducing gear 1:1.69
- Digital engine control with integrated propeller governor (using the gearbox oil system)
- Turbo charger with intercooler

Displacement: 1991 cm³ (121.5 in³)

Max. power: 123.5 kW (165.6 DIN-HP) at 2300 RPM at sea level and ISA

Max. continuous power: 114.0 kW (152.8 DIN-HP) at 2100 RPM at sea level and ISA

The indications for monitoring important engine parameters during operation are integrated within the Garmin G1000 display (if installed) or on the MED and SED (if installed). The engine can only be operated with the ENGINE MASTER switch ON. The engine has an EECU (Electrical Engine Control Unit) which receives its electrical power from the generator

when the engine is running. When the engine is not running, the ECU receives its electrical power from the battery.

7.9.2 OPERATING CONTROLS

I (a) POWER Lever

The engine performance is controlled by the power lever, situated on the large center console. **Front** and **rear** are defined in relation to the direction of flight.

This lever is used to set the desired engine power LOAD (%).

Lever forward (MAX) = Full power

Lever to rear (IDLE) = Idle

The ECU controls manifold pressure, injected fuel quantity and propeller speed according to the desired engine power preselected with the power lever.

The propeller governor is attached to the top rear side of the gearbox and uses gearbox oil for propeller pitch regulation. Following a loss of oil pressure the propeller blades go to the low pitch stop (maximum RPM), thus allowing continuation of the flight according to 3.3.6 - DEFECTIVE RPM REGULATING SYSTEM.

I (b) ELECTRIC MASTER

The key can be switched into three positions:

OFF Disconnecting battery power.

ON Connecting battery power to the power distribution system.

START Starting the engine.

I (c) ENGINE MASTER

The engine can only be cranked with the ENGINE MASTER switched to ON. To shut down the engine the ENGINE MASTER is switched to OFF.

I (d) ECU VOTER

For normal operation the switch is set to AUTO. The engine is controlled by either ECU A or ECU B. In case of a failure of the active electrical engine control unit (ECU) there is an automatic switch-over to the other ECU. If the automatic switch over fails, switch over can be done manually by switching to ECU A or ECU B. This procedure should only be applied in an emergency.

I (e) ECU TEST

POWER lever at IDLE:

By pushing and holding the button until the end of the procedure, the self-test of each engine control unit is started. The procedure is possible on the ground only. Otherwise the test will not start. During the procedure the ECU performs a switch from ECU A to ECU B or ECU B to ECU A, whichever is active at the moment, with the propeller cycling. The propeller RPM is monitored automatically by the ECU. When switching from one ECU to the other, a slight shake of the engine may occur. Finally the ECU switches back. After that both caution lights must extinguish and the engine must run without a change.

I (f) Alternate Air

In the event of power loss because of icing or blockage of the air filter, there is the possibility of drawing air from the engine compartment. The ALTERNATE AIR operating lever is located under the instrument panel on the left side of the center console. To open the alternate air source the lever is pulled to the rear. The alternate air source is closed, with the lever being in the forward position.

Placard on the lever, forward position:

ALTERNATE AIR

Placard on the lever, visible when lever is in the rearward position (alternate air open):

ALTERNATE AIR ON

7.9.3 PROPELLER

An mt-Propeller MTV-6-R/190-69 hydraulically regulated 3-bladed constant speed propeller is installed. The propeller has wood-composite blades with fiber-reinforced plastic coating and metal leading edge protection; in the region of the propeller hub the leading edge is coated with adhesive PU tape. These blades combine the lowest weight whilst minimizing vibration.

(a) Propeller Control

The propeller pitch is controlled by the P-853-16 mt-Propeller governor. The pitch is set by the ECU via an electro-mechanical actuator on the governor. To change the blade pitch angle, gearbox oil is pumped into the propeller hub which leads to an increase in pitch and a lower propeller RPM. When oil leaves the propeller hub pitch is reduced and RPM will increase.

In flight depending on the power setting the propeller pitch is adjusted such that the required RPM will be obtained as shown in the following diagram.

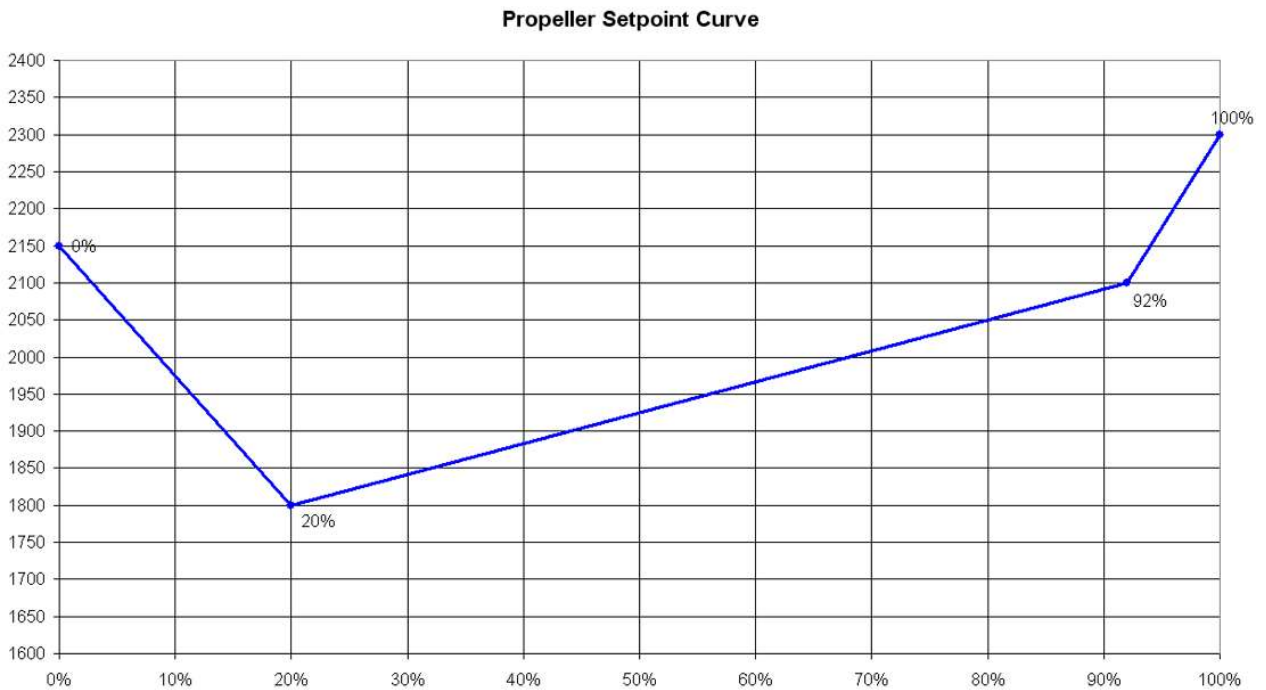

Ground Operation:

CAUTION

Operation on the ground at high RPM should be avoided as far as possible, as the blades could suffer stone damage. For this reason a suitable site for engine runs should be selected, where there are no loose stones or similar items.

WARNING

Never rotate the propeller by hand.

7.9.4 FUEL SYSTEM

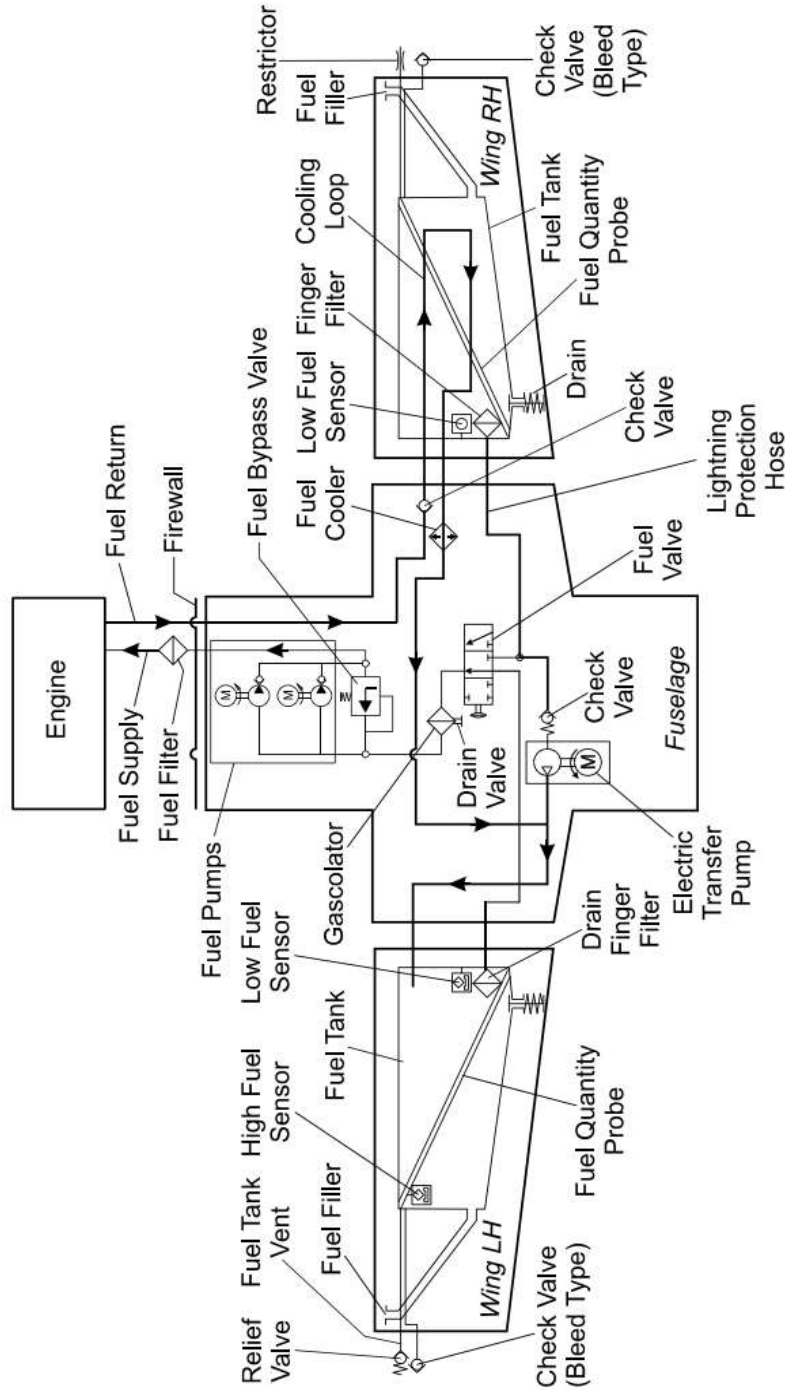

Standard Tank Schematic

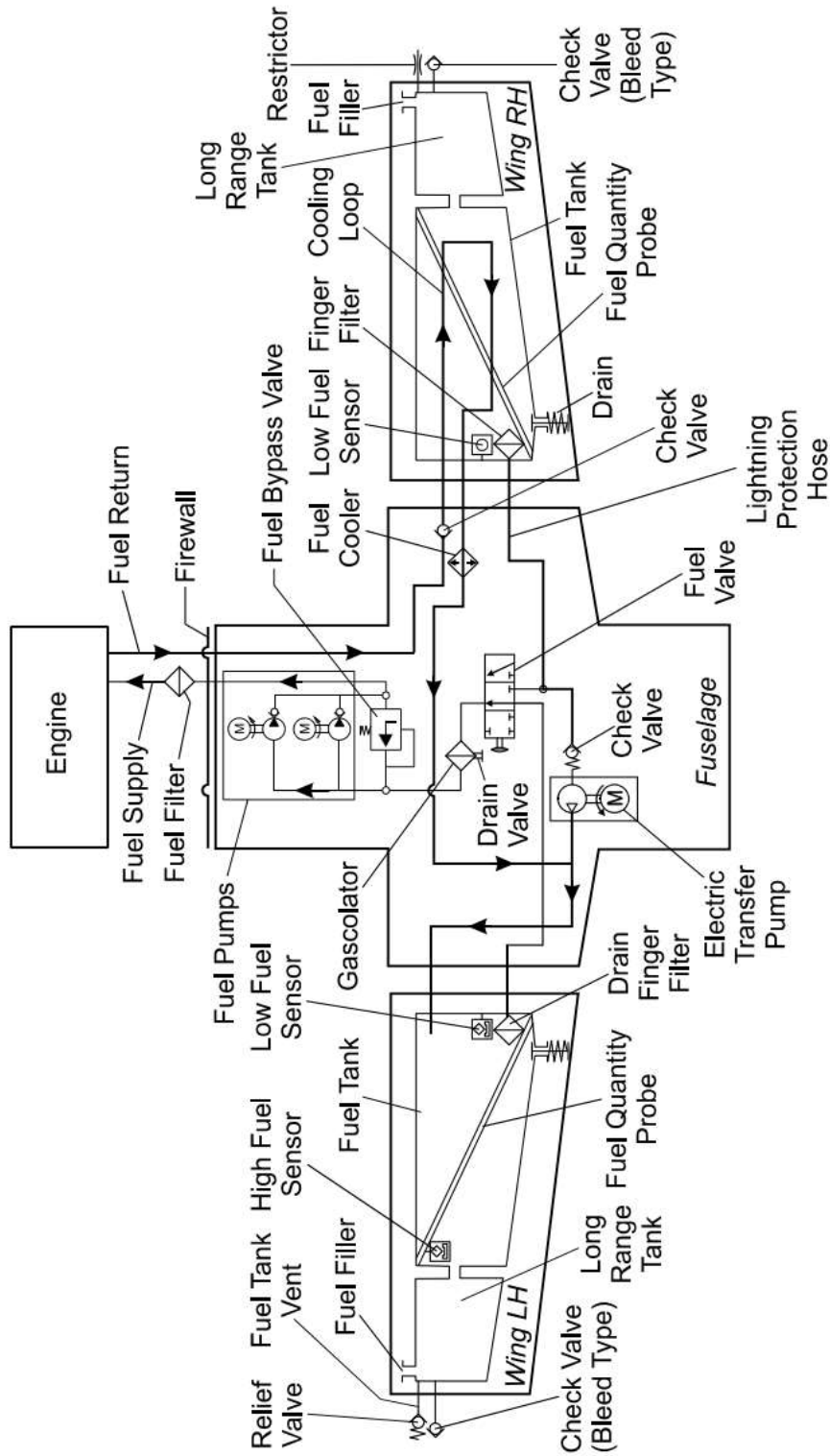

Long Range Tank Schematic

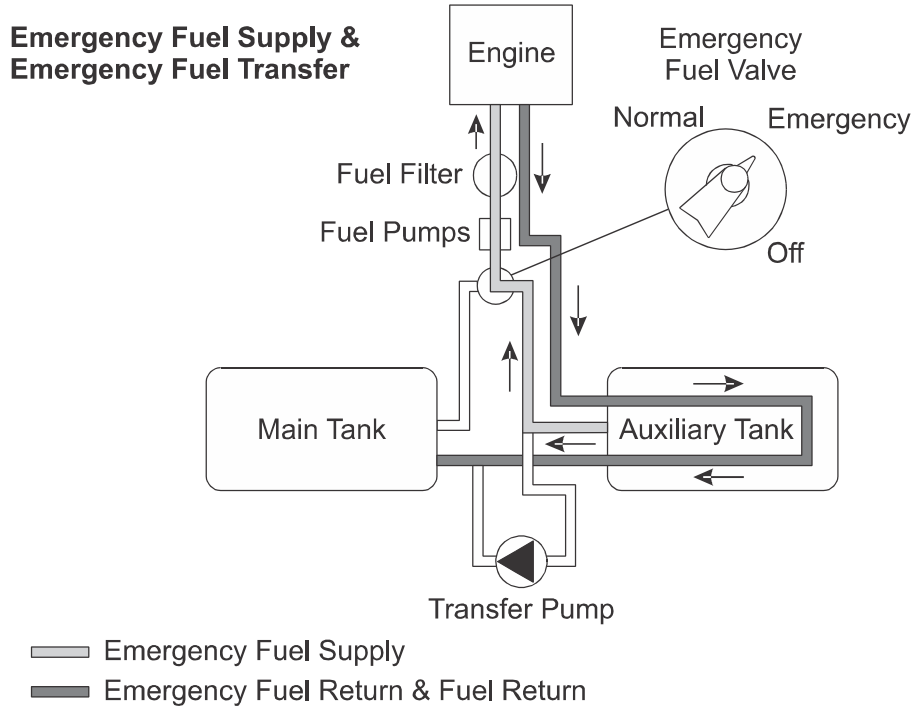
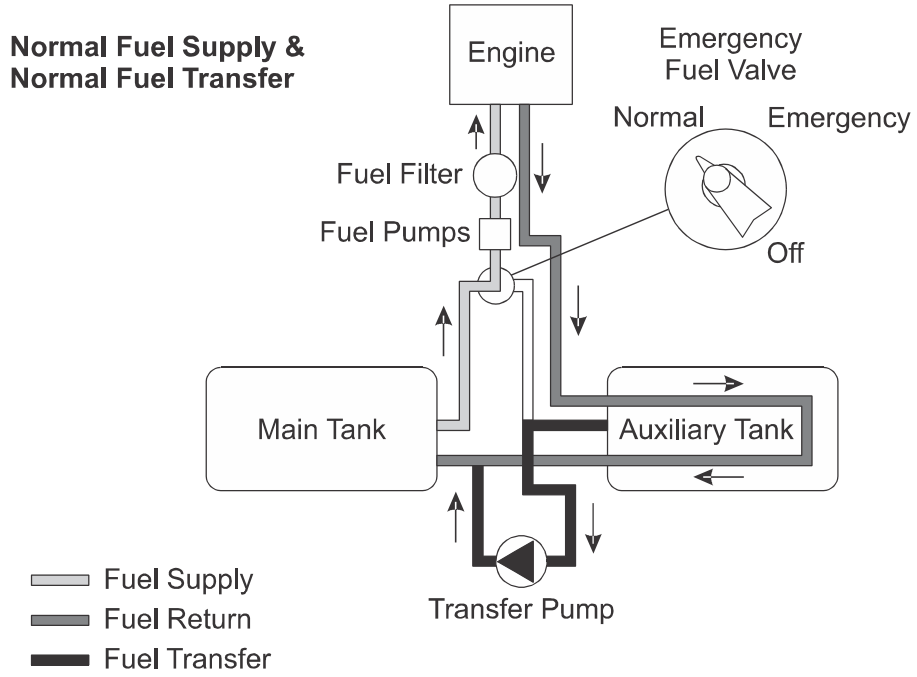

Fuel is stored in the fuel tanks which are located in the wings. Normally fuel is taken from the MAIN tank (left wing).

The fuel is injected with high pressure directly into the combustion chambers. The injection nozzles (one per cylinder) are supplied with fuel by the common rail. Pressure inside the rail is generated by a high pressure pump which receives fuel from two independent low pressure fuel pumps. Both pumps are powered electrically. Depending on the power setting the rail pressure is controlled by the ECU through an electric valve.

Fuel that is not injected into the combustion chambers is routed through the AUX fuel tank (right wing) and fed back into the MAIN fuel tank (left wing). This way hot fuel from the rail is cooled and cold fuel in both tanks is heated.

With the help of an electrical transfer pump fuel can be transferred from the AUX tank (right wing) to the MAIN tank (left wing) manually.

The transfer pump is switched off automatically when the auxiliary tank is empty or the main tank is full.

If fuel transfer with the transfer pump becomes impossible for any reason, fuel can also be taken directly from the AUX tank (right wing) by switching the fuel valve to the EMERGENCY position. As the return line goes back into the MAIN tank (left wing), fuel will then be transferred from right to left fuel tank.

■ As an option long range tanks may be installed.

CAUTION

Switching the fuel valve to the EMERGENCY position will start the transferring of fuel with the help of the electrically driven and engine driven fuel pumps from the auxiliary tank through the fuel return line to the main tank at a rate of approximately 45 US gal/h (170 liter/h) with the FUEL PUMPS switch in the OFF position. The fuel valve must be switched back to the NORMAL position before the auxiliary tank indication reads zero. If the fuel valve is not switched back to the NORMAL position, the engine will stop running as soon as the auxiliary tank is empty.

(a) Fuel Pumps

The engine is supplied with fuel by two parallel installed independent low pressure electrically driven fuel pumps. During normal operation one of the two fuel pumps is always working. In case of a low fuel pressure, the ECU switches automatically to the second fuel pump. During landing and take-off, or in case of a low fuel pressure both fuel pumps can be activated with the FUEL PUMPS switch. If both fuel pumps are set to ON the fuel pressure increases.

Each fuel pump is electrically connected to an ECU BUS and protected by a 7.5 A circuit breaker.

NOTE

By switching between ECU A and B the two independent electrical fuel pumps are switched over as well. In case of an emergency both pumps can be activated simultaneously by pushing the FUEL PUMPS switch to the ON position.

I (b) Fuel Valve

The fuel valve is located at the center console. The selectable positions are NORMAL, EMERGENCY and OFF. The desired position is reached by turning the valve handle while pulling up the safety latch on the valve handle. This is to ensure that a selection is not made unintentionally.

I (c) Standard Fuel Tanks*Main Tank (Left Wing):*

The main tank consists of an aluminum chamber and a filler tube which are connected by a flexible hose. There are two tank vents. One includes a check valve with a capillary and one includes a pressure relief valve, which operates at 150 mbar (2 PSI) and allows fuel and air to flow to the outside at higher internal pressure. The relief pressure valve protects the tank against high pressure if the tank will be overfilled in case of a fuel transfer failure. The check valve with capillary allows air to enter the tank but prevents flow of fuel to the outside. The capillary equalizes the air pressure during climb. The hose terminations are situated on the underside of the wing, approximately 2 meter (7 ft) from the wing tip.

Auxiliary Tank (Right Wing):

The auxiliary tank consists of an aluminum chamber and a filler tube which are connected by a flexible hose. There are two tank vents. One includes a check valve with a capillary and one includes a capillary. The check valve with capillary allows air to enter the tank during descent but prevents flow of fuel to the outside. The capillary equalizes the air pressure during climb. The second capillary is installed for additional safety. The hose terminations are situated on the underside of the wing, approximately 2 meter (7 ft) from the wing tip.

In each tank a coarse filter (finger filter) is fitted before the outlet. To allow draining of the tank, an outlet valve (drain valve) is installed at the lowest point of the fuel tank.

A gascolator is located at the bottom side of the fuselage which is the lowest point of the entire fuel system. A drain valve (pull to drain) is mounted to the gascolator, to allow the removal of water and sediment which has collected in the fuel system.

A capacity probe measures the fuel quantity in each tank. The indication is non-linear, therefore proportional calculations to determine the remaining fuel quantity or direct calculations of fuel consumption are not possible. Information about the fuel consumption can be found in Chapter 5 - PERFORMANCE.

(d) Long Range Tank (if installed)

The tank chamber has a capacity of approx. 5 US gal (19 liter). The ventilation system of the main and the auxiliary tank remains unchanged.

When the fuel quantity indicator reads zero, only the unusable fuel remains in the tank. The useable capacity of each tank is 19.5 US gal, the maximum quantity that can be indicated is 14 US gal. Up to an actual quantity of 14 US gal the indication is correct. At an actual quantity above 14 US gal the indication remains at 14 US gal.

NOTE

When the fuel quantity indicator reads 14 US gal, the correct fuel quantity must be determined with the alternate means for fuel quantity indication. If this measurement is not carried out, the fuel quantity available for flight planning is 14 US gal.

I (e) Alternate Means For Fuel Quantity Indication

The alternate means for fuel quantity indication allows the fuel quantity in the tank to be determined during the pre-flight inspection. It functions according to the principle of communicating containers. The fuel quantity measuring device has a recess which fits the airfoil of the wing. With this recess the device is held against the stall strip at the leading edge of the wing. The exact position is marked by a bore in the stall strip. Then the metal connector is pressed against the drain of the tank. The amount of fuel in the tank can now be read off from the vertical ascending pipe.

I For an exact indication the airplane must stand on level ground.

The designated place for the fuel quantity measuring device is the bag on the rear side of the pilot seat.

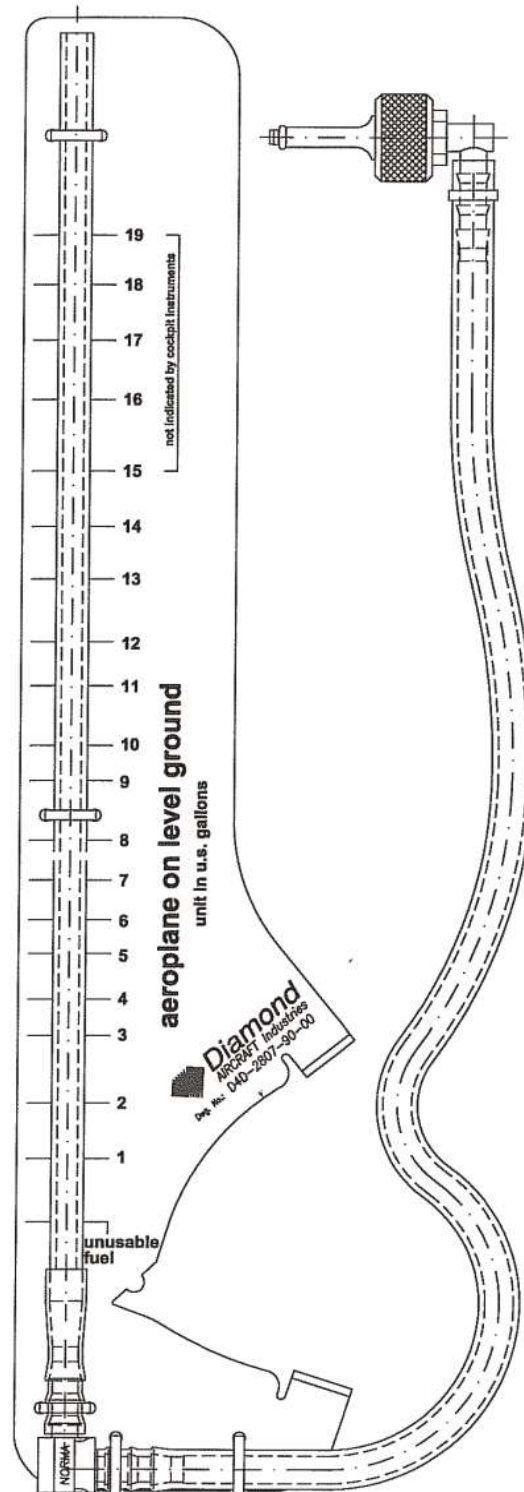

Fuel Quantity Measuring Device

(f) Alternate Means for Fuel Quantity Indication with Fuel Indicator II

For an exact indication, the airplane must stand on horizontal ground with the wings level.

The fuel indicator II includes a protractor for an additional pitch angle measurement. The fuel indicator II is placed on top of the fuselage tube just in front of the vertical tail. The lower edge of the fuel indicator II must be supported by the fuselage for its entire length. Read the pitch angle on the fuel indicator II and read the exact fuel quantity on the tables provided.

Standard tank configuration

Fuel Quantity Indicator II Pitch Angle Reading					Usable Fuel Quantity	
1°	2°	3°	4°	5°	US gal	Liter
up to 5	up to 5	up to 5	up to 5	up to 5	0	0
25	21	16	12	6	1	3.8
47	37	28	20	10	2	7.6
72	58	45	32	30	3	11.3
83	75	55	48	40	4	15.1
90	87	78	71	55	5	18.9
105	97	90	80	73	6	22.7
112	107	98	92	83	7	26.5
123	115	108	103	95	8	30.3
135	128	120	112	105	9	34.1
145	137	130	124	112	10	37.8
160	152	145	137	130	11	41.6
175	168	157	150	143	12	45.4
192	188	180	172	165	13	49.2
225	215	208	202	192	14	53.0

Long range tank configuration (if installed)

Fuel Quantity Indicator II Pitch Angle Reading					Usable Fuel Quantity	
1°	2°	3°	4°	5°	US gal	Liter
up to 5	up to 5	up to 5	up to 5	up to 0	0	0
35	25	16	8	1	1	3.8
45	36	30	20	15	2	7.6
65	48	40	35	28	3	11.3
75	68	55	47	39	4	15.1
92	80	72	66	55	5	18.9
110	90	78	70	65	6	22.7
118	108	95	87	77	7	26.5
130	123	110	100	90	8	30.3
140	132	115	102	95	9	34.1
148	136	129	122	113	10	37.8
162	149	138	130	118	11	41.6
174	158	150	138	131	12	45.4
180	171	162	156	146	13	49.2
185	180	175	166	156	14	53.0
200	195	184	176	168	15	56.8
217	205	196	189	181	16	60.6
232	220	215	204	196	17	64.4
248	238	230	221	214	18	68.1

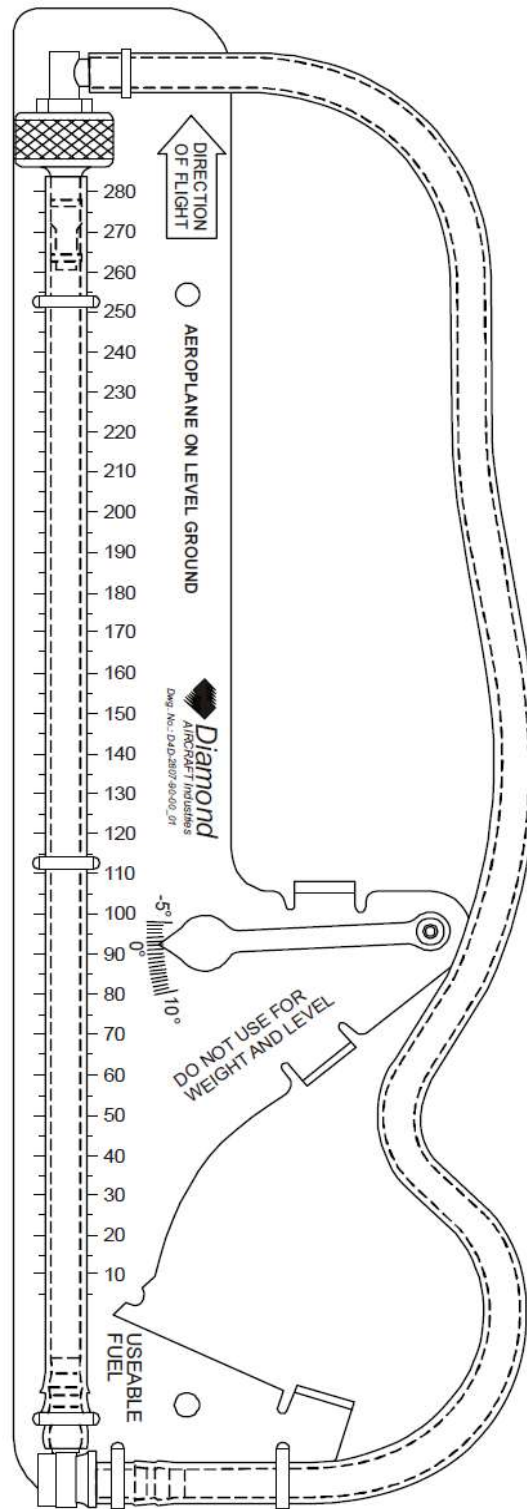

Fuel Quantity Indicator II

7.9.5 COOLING SYSTEM

The engine is liquid cooled. The liquid cooling system consists of a radiator circuit (coolant heat exchanger) and a bypass circuit (cabin heat exchanger). The radiator circuit is only open during hot coolant temperatures. This assures that a cold engine will warm up quickly. Upon reaching approximately 80°C (126°F) coolant temperature the radiator circuit is activated by a thermostatic valve.

Integrated in the bypass circuit is a coolant to air heat exchanger (cabin heat exchanger) which provides warm air for the cabin heat system.

A coolant expansion tank allows coolant expansion and pressure adjustment. The coolant system is protected against overpressure by means of a pressure relief valve.

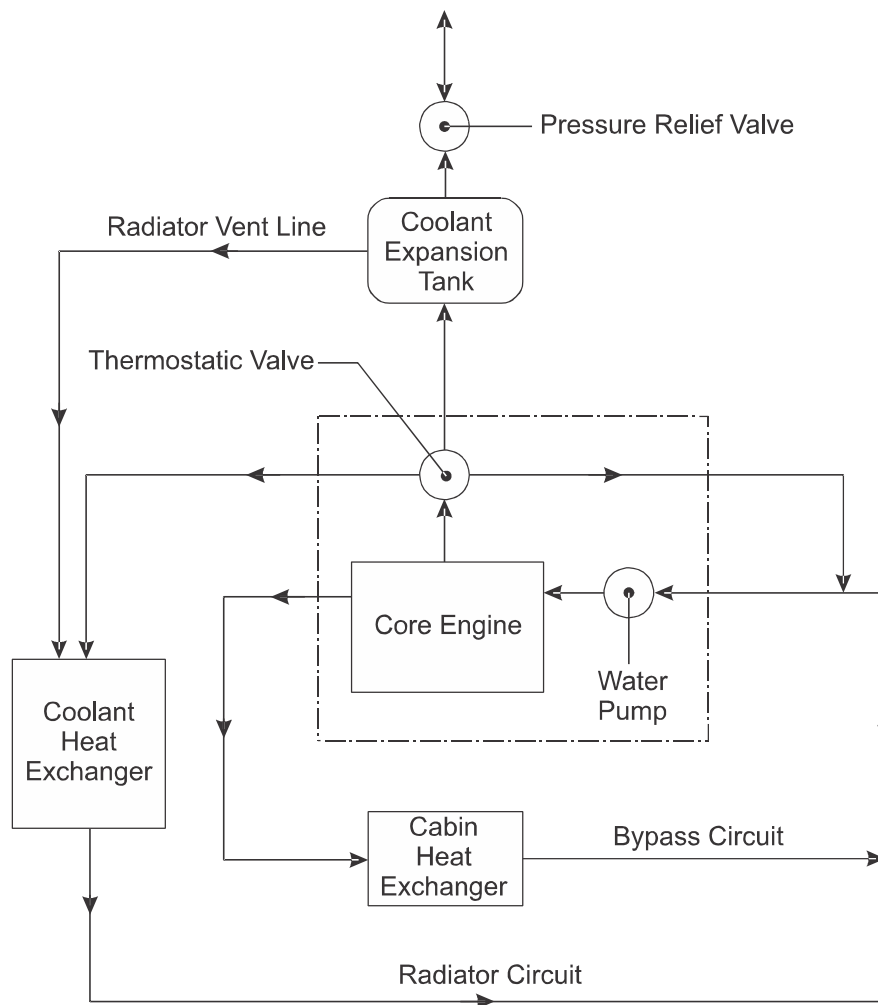

7.9.6 TURBO CHARGER SYSTEM

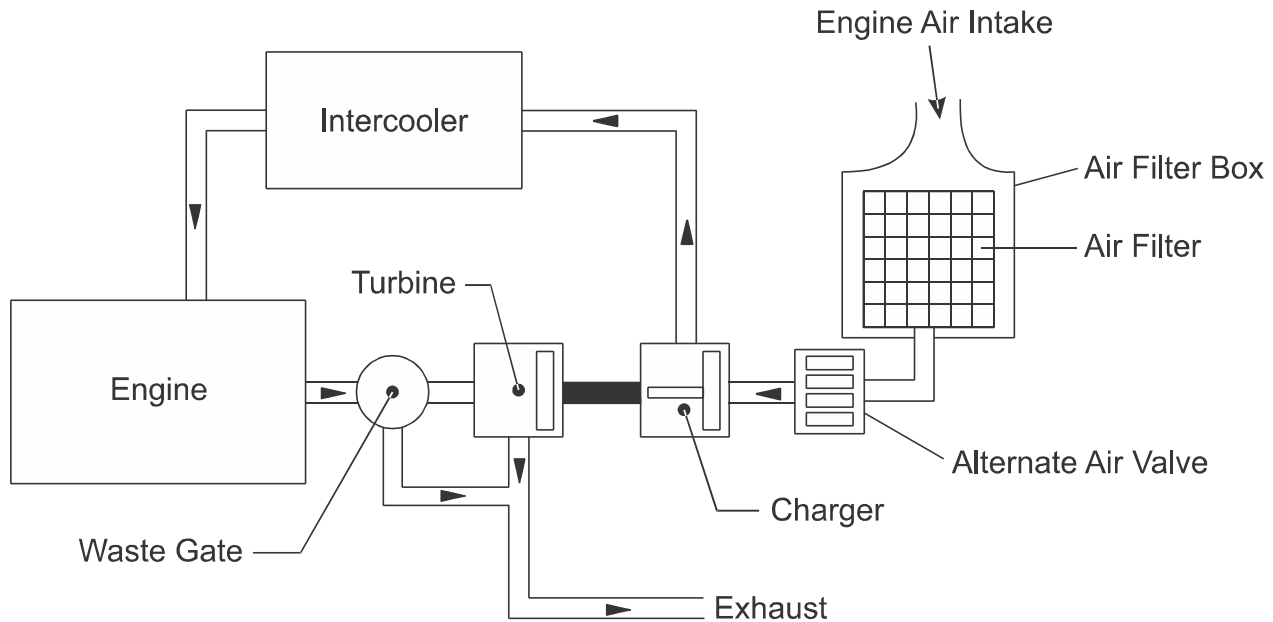

The intake air is compressed in the compressor which is driven by the turbine, and is subsequently cooled down in the intercooler. Cooling the air increases engine efficiency and power through the higher density of cold air. The exhaust system contains a manifold which collects exhaust gases from the outlets of the cylinders and feeds them to the turbine of the turbo charger. Behind the turbine the exhaust gases are guided through an exhaust pipe and exits at the bottom cowling opening. Excess exhaust gases bypass the turbine. The bypass is controlled by the ECU through the waste gate valve. A manifold pressure sensor behind the compressor allows the ECU to calculate the correct position of the waste gate valve. This prevents excessive manifold pressures at low density altitudes.

7.9.7 OIL SYSTEMS

The engine has two separate oil systems.

■ (a) Lubrication System (Engine and Turbo Charger)

The engine lubrication is a wet sump lubrication system. Oil is cooled by a separate cooler on the underside of the engine.

A dip-stick is provided to check the oil quantity through an inspection door on the LH side of the upper cowling. If required, oil can also be filled in there (for specified oil types refer to 2.4 - POWER-PLANT LIMITATIONS).

■ (b) Gearbox and Propeller Governor System

■ The second oil circuit lubricates the gearbox and serves the governor system and the regulation of the propeller.

■ Gearbox oil quantity can be checked via an inspection glass which can be reached through an inspection door on the LH side of the upper cowling.

CAUTION

■ If the gearbox oil quantity is too low, unscheduled maintenance is necessary (for specified oil types refer to 2.4 - POWER-PLANT LIMITATIONS).

7.10 ELECTRICAL SYSTEM

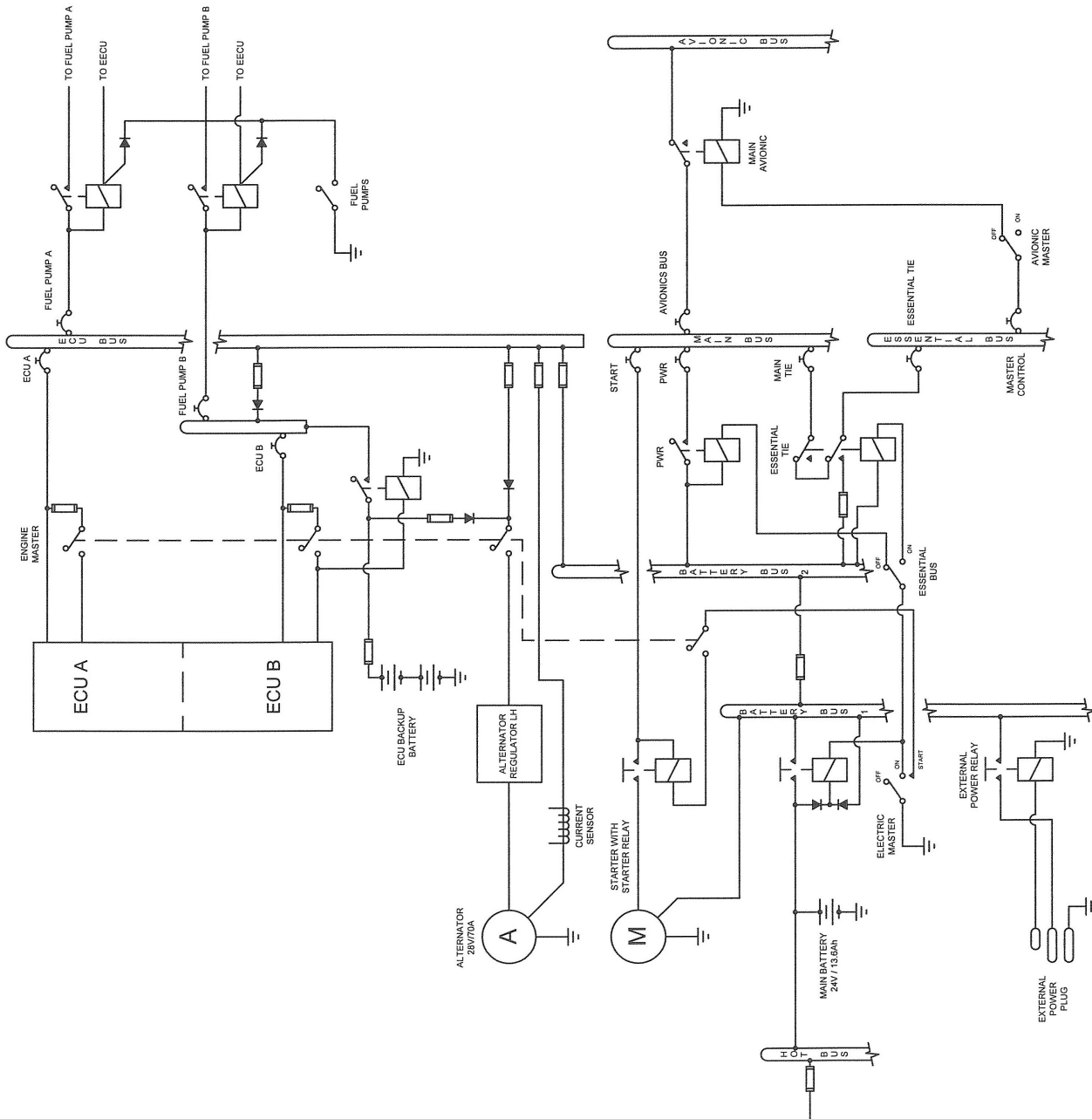

Electrical System Schematic

7.10.1 GENERAL

The DA 40 NG has a 28 Volt DC system, which can be sub-divided into:

- Power generation
- Storage
- Distribution
- Consumers

■ (a) Power Generation

Power generation is provided by a 70 Ampère alternator (generator) which is mounted on the bottom left side of the engine. The alternator is driven by a flat-belt.

The power output line of the alternator is connected to the ENG ECU bus via a 100 A fuse, which is installed in the instrument panel. The power output line also runs through the current sensor, which provides an indication of the power being supplied to the electrical system by the alternator including the current for battery charging.

In the event of a main battery failure the field of the alternator is energized by two 12 V, 7.2 Ah sealed-lead-acid batteries (ECU backup batteries) which are installed behind the first ring frame. The ENGINE MASTER switch connects the ECU backup battery to the alternator voltage regulator via a 10 A fuse.

Alternator Control:

The alternator control unit includes a comprehensive set of diagnostic functions that will warn the operator using a warning message (ALTN FAIL on the G1000 system (if installed) or ALTERNATOR on the White Wire annunciator panel (if installed)) in case of over- or undervoltage as well as a couple of other internal warning levels.

I (b) Storage

Main battery power is stored in a 24 V, 13.6 Ah lead-acid battery mounted behind the baggage compartment frame. The main battery is connected to the battery bus via the battery-relay which is installed in the relay junction box behind the baggage compartment frame.

The battery relay is controlled with the ELECTRIC MASTER key switch which is located in the center of the instrument panel.

In addition, two 12 V, 7.2 Ah sealed-lead-acid batteries (ECU backup-batteries) are installed behind the first ring frame as a further source of electrical power for the Engine Control Unit (ECU B only).

Under normal operating conditions the ECU backup batteries are charged by the ECU bus. In the event of an alternator failure and a depleted main battery the ECU backup batteries automatically supply electrical power to ECU B via a 32 A fuse. This prevents the engine from stopping in the unlikely event of an alternator failure and a totally discharged main battery.

In addition, a non-rechargeable dry battery is installed in the IFR model as a further source of power for the attitude gyro (artificial horizon) and the flood light. When the EMERGENCY switch is set to ON, these two systems are supplied with power for 1 hour, independent of all other electrical consumers. During each 100 hour inspection, this battery is checked for proper functioning. Every 2 years or after use (broken seal on the switch) the battery pack must be replaced.

I (c) Distribution

Electrical power is distributed via the hot battery bus, the battery bus 1, the battery bus 2, the ECU-bus, the main bus, the essential bus and the avionic bus.

Hot Battery Bus:

The hot battery bus is directly connected to the main-battery installed in the relay junction box and cannot be disconnected from the main battery. The hot battery bus provides power to the accessory power plug and ELT which are protected by their own fuses.

Battery Bus 1:

The battery bus 1 is connected to the main-battery via the battery-relay which can be controlled by the ELECTRIC MASTER key switch. The battery bus 1 provides power to the battery bus 2 and heavy duty power to the starter.

The battery bus 1 is also connected to the power input line of the external power plug.

Battery Bus 2:

The battery bus 2 is connected to the battery bus 1 via a 100 A fuse and provides power to the ECU bus via an 80 A fuse. It also provides power to the main bus via the power relay which can be controlled by the ELECTRIC MASTER key switch and the ESSENTIAL BUS switch. The ELECTRIC MASTER key switch must be set to ON and the ESSENTIAL BUS switch must be set to OFF to connect the battery bus to the main bus.

ECU Bus:

I The ECU bus is connected to the battery bus 2 via an 80 A fuse and provides power for the ECU A and ECU B and their fuel pumps. It is also connected to the power output line of the alternator via a 100 A fuse. It also provides power for charging the ECU backup-battery. The ENGINE **I** MASTER switch must be set to ON to connect ECU A and ECU B to the ECU bus.

Main Bus:

The main bus is connected to the battery bus via the power-relay. It provides power to the consumers directly connected to the main bus and the avionic bus via the avionic master-relay. The AVIONIC MASTER switch must be set to ON to connect the main bus to the avionic bus. Under normal operating conditions the main bus is also connected to the essential bus via the essential tie-relay. In the event of an alternator failure the pilot must switch ON the ESSENTIAL BUS switch (refer to Section 3.4 - FAILURES IN THE ELECTRICAL SYSTEM). This separates the main bus from the battery bus and the essential bus and the equipment connected to the main bus no longer has power.

Essential Bus:

Under normal operating conditions the essential bus is connected to the main bus via the essential tie-relay. The essential bus provides power to the consumers connected to the essential bus. The AVIONIC MASTER switch must be set to ON to connect the essential bus to the avionic bus. In the event of an alternator failure the pilot must switch ON the ESSENTIAL BUS switch (refer to Section 3.4 - FAILURES IN THE ELECTRICAL SYSTEM). This separates the essential bus from the main bus. The essential bus is then connected to the battery bus 2 which provides battery power for a limited time to the equipment essential for safe flight and landing.

(d) Consumers

The individual consumers (e.g. radio, electrical fuel transfer pump, position lights, etc.) are connected to the appropriate bus via automatic circuit breakers.

Designations and abbreviations used to identify the circuit breakers are explained in Section 1.5 - DEFINITIONS AND ABBREVIATIONS.

| (e) Voltmeter

The voltmeter shows the voltage of the essential bus. Under normal operating conditions the alternator voltage is shown, otherwise it is the voltage of the main battery.

| (f) Ammeter

The ammeter displays the intensity of current which is supplied to the electrical system by the alternator, including the current for battery charging.

| (g) Landing and Taxi Lights

Landing and taxi lights are built into the left wing, and are each operated by means of a switch (LANDING, TAXI) on the row of switches on the instrument panel.

| (h) Position and Strobe Lights

Combined position and strobe lights (anti collision lights) are installed on both wing tips. Each system is operated by a switch (POSITION, STROBE) on the row of switches on the instrument panel.

| (i) Flood Light

A two-dimensional light emitter is mounted above the instrument panel. It illuminates the instrument panel as well as all levers, switches, etc. With a rotary button (FLOOD) in the left-hand section of the instrument panel the flood light is switched on and its brightness is adjusted.

(j) Instrument Lighting

With a rotary button (INSTRUMENT) in the left-hand section of the instrument panel the internal lighting of the instruments is switched on and its brightness is adjusted.

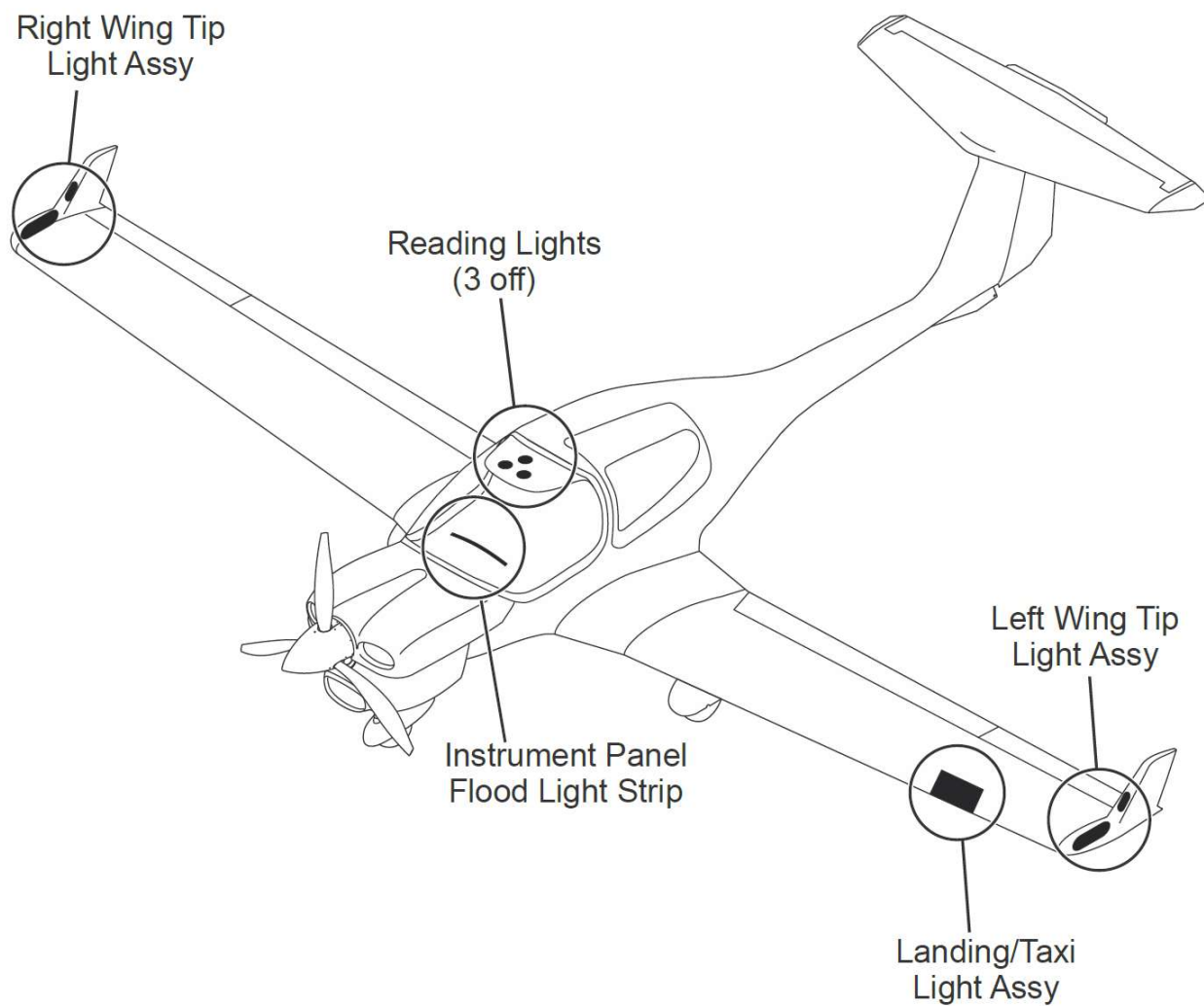

I (k) Pitot Heating

The Pitot probe, which provides measurement for the Pitot-static system, is electrically heated. The heating is activated with a switch (PITOT) on the row of switches on the instrument panel. The temperature is automatically kept constant by means of a thermal switch on the Pitot probe, and as an additional safety measure a thermal fuse is built in. If this thermal fuse is activated, the Pitot heating can no longer be switched on. PITOT FAIL on the G1000 (if installed) or PITOT on the White Wire annunciator panel (if installed) will be displayed, if the thermal fuse or the thermal switch is activated and the PITOT HT is set to ON. The PITOT HT OFF indication on the G1000 (if installed) is on if the Pitot heating is switched off.

7.10.2 ENGINE CONTROL UNIT / ECU

(a) Engine Control and Regulation

The Electrical ECU is used to control the engine actuator (e.g. fuel injector) according to the engine sensor information. The ECU monitors, controls and regulates all important parameters for engine operation.

Sensors installed are:

- Oil temperature (lubrication system engine) / OIL TEMP (G1000, if installed), OT (MED, if installed)
- Oil pressure (lubrication system engine) / OIL PRES (G1000, if installed), OP (MED, if installed)
- Coolant temperature / COOLANT TEMP (G1000, if installed), CT (MED, if installed)
- Gearbox temperature / GEARBOX (G1000, if installed), GT (MED, if installed)
- Camshaft RPM (twice)
- Crankshaft RPM (twice)
- Fuel pressure in the common rail
- Manifold pressure
- Manifold air temperature
- Ambient air pressure
- Propeller governor / oil pressure
- POWER lever position (twice)
- Voltage
- Starter switch signal
- Fuel pressure
- VOTER switch signal
- ECU TEST switch signal

In accordance with the received signals and a comparison with the programmed characteristic diagrams the necessary inputs are calculated and transmitted by the following signal lines to the engine:

- Signal for propeller governor pressure valve
- Signal for the rail-pressure regulation valve
- Signal for each of the 4 injection nozzles
- Activation of the glow plugs
- Signal for the waste gate valve

The following alerts are displayed on the PFD of the G1000 (if installed) or White Wire annunciator panel (if installed):

- Glow sparks active
- Status ECU A
- Status ECU B
- Low fuel pressure warning (on the G1000, if installed)

█ The Electronic ECU consists of two similar ECUs. A VOTER switch is integrated in the Electronic ECU and proposes (if set to AUTO) an ECU to control the engine regarding the ECU operating hours or - in case of a failure - the ECU with better engine control capability. If the VOTER switch is set to A or B, the EECU is forced to control the engine with ECU A or ECU B, respectively.

█ A fault in one of the ECUs is indicated by a caution message (ECU A/B FAIL on the PFD (if G1000 is installed) or ECU A/B on the White Wire annunciator panel (if installed)). Two types of faults are known:

- Faults which lead to a latched caution indication
- Faults which lead to a non-latched indication

█ In case of a latched caution, unscheduled maintenance is necessary and Austro Engine GmbH has to be informed.

7.11 PITOT-STATIC SYSTEM

Total pressure is measured at the leading edge of a Pitot probe under the left wing. Static pressure is measured through the static ports in the rear fuselage. To protect against dirt and condensation there are filters in the system. The Pitot probe is electrically heated.

With the alternate static valve, the static pressure in the cabin can be used as static pressure source in the event of a failure of the static system.

7.12 STALL WARNING SYSTEM

If airspeed drops, suction on the orifice at the leading edge of the left wing will increase until the stall warning horn, located in the instrument panel, will sound. The horn becomes progressively louder the closer one gets to stalling speed. Suction at an orifice on the left wing leading edge activates the horn via a hose. The orifice for the stall warning in the left wing is marked by a red ring.

CHAPTER 8

AIRPLANE HANDLING, CARE AND MAINTENANCE

		Page
8.1	INTRODUCTION	8-3
8.2	AIRPLANE INSPECTION INTERVALS	8-3
8.3	AIRPLANE ALTERATIONS OR REPAIRS	8-4
8.4	GROUND HANDLING / ROAD TRANSPORT	8-4
8.4.1	GROUND HANDLING WITHOUT TOW BAR	8-4
8.4.2	GROUND HANDLING WITH TOW BAR	8-5
8.4.3	PARKING	8-7
8.4.4	MOORING	8-10
8.4.5	JACKING	8-10
8.4.6	ALIGNMENT	8-10
8.4.7	ROAD TRANSPORT	8-11
8.5	CLEANING AND CARE	8-12
8.5.1	PAINTED SURFACES	8-12
8.5.2	CANOPY AND REAR DOOR	8-12
8.5.3	PROPELLER	8-13
8.5.4	ENGINE	8-13
8.5.5	INTERIOR SURFACES	8-13
8.6	DE-ICING ON THE GROUND	8-14

I Intentionally left blank.

8.1 INTRODUCTION

Chapter 8 contains the manufacturer's recommended procedures for proper ground handling and servicing of the airplane. The Airplane Maintenance Manual (Doc. No. 6.02.15) lists certain inspection and maintenance requirements which must be followed if the airplane is to retain a new plane performance and reliability.

8.2 AIRPLANE INSPECTION INTERVALS

Inspections are scheduled every 100, 200 and 1000 hours. Independent of the flight hours an annual inspection must be performed every year. The respective inspection checklists are prescribed in the Airplane Maintenance Manual, Chapter 05.

For maintenance work on engine and propeller, the currently effective Operator's Manuals, Service Instructions, Service Letters and Service Bulletins of Austro Engine and mt-Propeller must be followed. For airframe inspections, the currently effective checklists/manuals, Service Bulletins and Service Instructions of the manufacturer must be followed.

CAUTION

Unscheduled maintenance checks are required after:

- Hard landings
- Propeller strike
- Engine fire
- Lightning strike
- Occurrence of other malfunctions and damage

Unscheduled maintenance checks are described in the Airplane Maintenance Manual (Doc. No. 6.02.15; Section 05-50).

8.3 AIRPLANE ALTERATIONS OR REPAIRS

Alterations or repairs of the airplane may be carried out only according to the Airplane Maintenance Manual, Doc. No. 6.02.15, and only by authorized personnel.

8.4 GROUND HANDLING / ROAD TRANSPORT

8.4.1 GROUND HANDLING WITHOUT TOW BAR

During forward traversing the nose wheel will follow the movement of the airplane. A change in direction is achieved by pulling on the propeller near the spinner. To traverse in the rear direction, the tail section of the airplane should be pushed down until the nose wheel is clear of the ground. This method can also be used to turn the airplane around its main landing gear.

8.4.2 GROUND HANDLING WITH TOW BAR

For pushing or pulling the airplane on the ground, it is recommended to use the tow bar which is available from the manufacturer. The tow bar is bent apart and engaged in the appropriate holes in the nose wheel fairing as shown on the picture below. The arresting knob must be fully engaged.



WARNING

The tow bar must be removed before starting the engine.

CAUTION

The tow bar may only be used for moving the airplane on the ground by hand. After moving the airplane, the tow bar must be removed.

NOTE

When moving the airplane rearward, the tow bar must be held firmly to prevent abrupt sideward deflection of the nose wheel.

8.4.3 PARKING

For short term parking, the airplane must be positioned into the wind, the parking brake must be engaged and the wing flaps must be in the retracted position. For extended and unattended parking, as well as in unpredictable wind conditions, the airplane must be anchored to the ground or placed in a hangar. Parking in a hangar is recommended.

For outdoor parking at temperatures below -38°C (-36.4°F), make sure that the distilled water / coolant mixture ratio is 40 % to 60 %.

If the battery heating system (OÄM 40-363) is installed, it is recommended to use the system when the airplane is parked at outside air temperature below 0°C (32°F).

(a) Control Surfaces Gust Lock

The manufacturer offers a control surfaces gust lock which can be used to block the primary controls. It is recommended that the control surfaces gust lock be used when parking outdoors, because otherwise the control surfaces can hit the stops in strong tail wind. This can lead to excessive wear or damage.

WARNING

The control surfaces gust lock must be removed before flight.

The control surfaces gust lock is installed as follows:

1. Move the rudder pedals fully rearward.
2. Engage the control surfaces gust lock with the pedals.
3. Engage the stick, wrap straps around stick once.
4. Attach the locks and tighten the straps.

For removal, reverse the sequence.

NOTE

It is recommended to cover the canopy when the airplane is parked outdoors, in direct sunlight, at outside air temperatures above +25 °C (77 °F), in order to prevent excessive heat generation within the instrument panel which can cause damage to the equipment. Such a canopy cover is available from Diamond Aircraft Industries, P/N: S_30172.

NOTE

The figures below show the gust lock installed in a DA 42. Nevertheless, the figures are an accurate depiction of the gust lock installed correctly in the DA 40 NG.



8.4.4 MOORING

The tail fin of the airplane has a hole which can be used to tie-down the airplane to the ground. Also on each wing near the wing tip, an eyelet with a metric M8 thread can be installed and used as tie-down points.

8.4.5 JACKING

The airplane can be jacked at the two jackpoints located on the lower side of the fuselage's LH and RH root ribs as well as at the tail fin.

8.4.6 ALIGNMENT

For alignment push down on the tail section at the fuselage/vertical tail junction until the nose wheel is clear of the ground. With the nose wheel free, the airplane can be turned around the main landing gear. After turning the airplane into the correct position, release the tail section slowly until the nose wheel is back on the ground.

8.4.7 ROAD TRANSPORT

For transporting the airplane on the road it is recommended that an open trailer be used. All airplane components must be stored on a cushioned surface and secured to avoid any movement during transportation.

NOTE

Disassembling and assembling of the airplane is a maintenance action and requires qualified personnel.

(a) Fuselage:

The fuselage should stand on the main and nose landing gear. It must be ensured that the fuselage will not move in any direction. Furthermore, it must be ensured that the propeller has sufficient clearance so that it cannot be damaged due to fuselage movement during transportation.

(b) Wings:

For transportation, both wings must be removed from the fuselage. To avoid any damage, the wings must be stored in an upright position on the leading edge with the root rib area positioned on an upholstered profiled surface with a width of at least 400 mm (1.3 ft). The outside wing area (approximately 3 m (10 ft) from the root rib area) must be placed on an upholstered profiled surface with a minimum width of 300 mm (1 ft).

The wings must be secured to avoid any sliding movement to the rear.

(c) Horizontal Stabilizer:

The horizontal stabilizer must be stored flat on the trailer and secured with straps, or in an upright position sitting on the leading edge on a profiled surface. All storing surfaces must be upholstered with felt or cellular rubber.

8.5 CLEANING AND CARE

CAUTION

The airplane must be kept clean. The bright surface prevents the structure from overheating.

CAUTION

Excessive dirt deteriorates the flight performance.

8.5.1 PAINTED SURFACES

The entire surface of the airplane is painted with a white weatherproof two component paint. Nevertheless, it is recommended to protect the airplane against moisture and dampness. It is also recommended not to store the airplane outside for long periods of time.

Dirt, insects, etc. can be removed with water alone and if necessary with a mild detergent. An automotive paint cleaner can be used for stubborn spots. For best results, clean the airplane after the day's flying is ended, so that the dirt will not become ingrained.

Oil stains, exhaust stains, etc. on the lower fuselage skin can be removed with a cold detergent. Before starting, ensure that the detergent does not affect the surface finish. Use commercial automotive preservatives without silicone additives to conserve the paint finish.

8.5.2 CANOPY AND REAR DOOR

The canopy and rear door should be cleaned with **Plexiklar** or any other acrylic glass detergent if available; otherwise use lukewarm water. Final cleaning should be done with a clean piece of chamois-leather or soft cloth. Never rub or polish dry acrylic glass.

8.5.3 PROPELLER

Damage and malfunctions during operation must be inspected by authorized personnel.

(a) Surface

The manufacturer uses PU paint or acrylic paint which is resistant to almost any solvent. The blades may be treated with commercial automotive cleaning agents or preservatives. The penetration of moisture into the wooden core must be avoided by all means. Should doubts arise, an appropriately rated inspector must be consulted.

8.5.4 ENGINE

Engine cleaning is part of the scheduled inspections.

8.5.5 INTERIOR SURFACES

The interior should be cleaned using a vacuum cleaner. All loose items (pens, bags etc.) should be removed or properly stored and secured.

All instruments can be cleaned using a soft dry cloth, plastic surfaces should be wiped clean using a damp cloth without any cleaning agents.

CAUTION

The PFD and MFD displays use a lens coated with a special anti-reflective coating that is very sensitive to skin oils, waxes, and abrasive cleaners. CLEANERS CONTAINING AMMONIA WILL HARM THE ANTI-REFLECTIVE COATING. It is very important to clean the lens using a clean, lint-free cloth and an eyeglass lens cleaner that is specified as safe for anti-reflective coatings.

8.6 DE-ICING ON THE GROUND(a) Approved De-Icing Fluids

Manufacturer	Name
Kilfrost	TKS 80
Aeroshell	Compound 07
Any source	AL-5 (DTD 406B)

(b) De-Icing Procedure

1. Remove any snow from the airplane using a soft brush.
2. Spray de-icing fluid onto ice-covered surfaces using a suitable spray bottle.
3. Use a soft piece of cloth to wipe the airplane dry.

CHAPTER 9

SUPPLEMENTS

	Page
9.1 INTRODUCTION	9-3
9.2 LIST OF SUPPLEMENTS	9-4

I

Intentionally left blank.

9.1 INTRODUCTION

Chapter 9 contains information concerning additional (optional) equipment of the DA 40 NG.

Unless otherwise stated, the procedures given in the Supplements must be applied in addition to the procedures given in the main part of the Airplane Flight Manual.

All approved supplements are listed in the List of Supplements in this Chapter.

The Airplane Flight Manual contains exactly those Supplements which correspond to the installed equipment according to the Equipment Inventory of Section 6.5.

NOTE

The listed Supplements cannot be installed in any arbitrary combination.

9.2 LIST OF SUPPLEMENTS

Airplane S/N:		Registration:		Date:	
Sup. No.	Title	Rev. No.	Date	Applicable	
				YES	NO
A01	Garmin G1000 Avionics System	2	08 Apr 2015	<input type="checkbox"/>	<input type="checkbox"/>
A02	Garmin G1000 NXi Avionics System	1	08 Feb 2019	<input type="checkbox"/>	<input type="checkbox"/>
A03	Intercom System PM 1000 II, PS Engineering Inc.	0	09 May 2017	<input type="checkbox"/>	<input type="checkbox"/>
A05	Conventional Cockpit DA 40 NG Club	0	15 Mar 2011	<input type="checkbox"/>	<input type="checkbox"/>
A13	Autopilot System KAP 140, Bendix/King	1	15 Mar 2011	<input type="checkbox"/>	<input type="checkbox"/>
A29	DA 40 NG Garmin Transponder GTX 328	0	15 Mar 2011	<input type="checkbox"/>	<input type="checkbox"/>
A30	DA 40 NG Garmin COM/NAV, SL 30	0	15 Mar 2011	<input type="checkbox"/>	<input type="checkbox"/>
A33	Garmin G1000 SBAS and P-RNAV Operation	2	01 Jul 2014	<input type="checkbox"/>	<input type="checkbox"/>
E07	Operation with Ventilation Inlet Baffle	1	01 Jul 2014	<input type="checkbox"/>	<input type="checkbox"/>
N017	Operation in CIS	2	17 Dec 2013	<input type="checkbox"/>	<input type="checkbox"/>
N023	Operation in Brazil	0	16 May 2022	<input type="checkbox"/>	<input type="checkbox"/>
N048	Operation in the Ukraine	0	01 Jul 2011	<input type="checkbox"/>	<input type="checkbox"/>
O01	Use of the DA 40 NG as Tow-Plane	1	01 Jul 2014	<input type="checkbox"/>	<input type="checkbox"/>

Airplane S/N:		Registration:		Date:	
Sup. No.	Title	Rev. No.	Date	Applicable	
				YES	NO
O02	Landing Gear with Large Tyres and 1280 kg Maximum Landing Mass	2	01 Jul 2014	<input type="checkbox"/>	<input type="checkbox"/>
O03	Cold Weather Operation	1	01 Jul 2014	<input type="checkbox"/>	<input type="checkbox"/>
O04	Diesel Operation	0	06 Dec 2013	<input type="checkbox"/>	<input type="checkbox"/>
O09	Operation with D64-9028-11-01 Fuel Pumps	3	30 Sep 2024	<input type="checkbox"/>	<input type="checkbox"/>
S04	406MHz Emergency Locator Transmitter Artex ME 406	0	01 Apr 2010	<input type="checkbox"/>	<input type="checkbox"/>
S06	G1000 Synthetic Vision Technology	1	15 Mar 2011	<input type="checkbox"/>	<input type="checkbox"/>
S07	Recirculating Air - Cabin Cooling	7	22 Jun 2016	<input type="checkbox"/>	<input type="checkbox"/>
S10	Flight Data Logging Device	0	29 Jan 2016	<input type="checkbox"/>	<input type="checkbox"/>
S11	Garmin GTX 335R/345R Transponders with ADS-B	0	15 Apr 2019	<input type="checkbox"/>	<input type="checkbox"/>

I

Intentionally left blank.